



CAT521

Configured Digitally Programmable Potentiometer (DPP™): Programmable Voltage Applications

FEATURES

- 8-bit DPP configured as a programmable voltage source in DAC-like applications
- Buffered wiper output
- Non-volatile NVRAM memory wiper storage
- Output voltage range includes both supply rails
- 1 LSB accuracy, high resolution
- Serial Microwire-like interface
- Single supply operation: 2.7V - 5.5V
- Setting read-back without effecting outputs

APPLICATIONS

- Automated product calibration
- Remote control adjustment of equipment
- Offset, gain and zero adjustments in self-calibrating and adaptive control systems
- Tamper-proof calibrations
- DAC (with memory) substitute

DESCRIPTION

The CAT521 is a 8-bit digitally-programmable potentiometer (DPP™) configured for programmable voltage and DAC-like applications. Intended for final calibration of products such as camcorders, fax machines and cellular telephones on automated high volume production lines, it is also well suited for self-calibrating systems and for applications where equipment which requires periodic adjustment is either difficult to access or in a hazardous environment.

The programmable DPP has an output voltage range which includes both supply rails. The wiper is buffered by a rail to rail op amp. The wiper setting, stored in non-volatile NVRAM memory, is not lost when the device is powered down and is automatically reinstated when power is returned. The wiper can be dithered to test new output values without effecting the stored

settings and stored settings can be read back without disturbing the DPP's output.

The CAT521 is controlled with a simple 3-wire, Microwire-like serial interface. A Chip Select pin allows several devices to share a common serial interface. Communication back to the host controller is via a single serial data line thanks to the CAT521 Tri-Stated Data Output pin. A RDY/BSY output working in concert with an internal low voltage detector signals proper operation of the non-volatile NVRAM memory Erase/Write cycle.

The CAT521 is available in 0°C to 70°C commercial and -40°C to 85°C industrial operating temperature ranges. Both 14-pin plastic DIP and surface mount packages are available.

FUNCTIONAL DIAGRAM

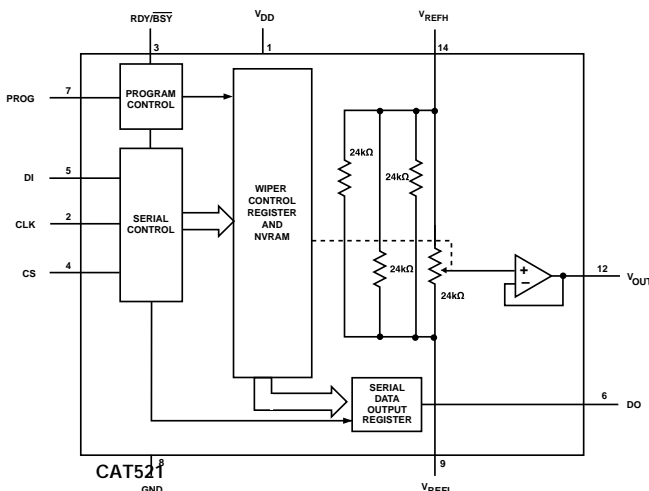

PIN CONFIGURATION

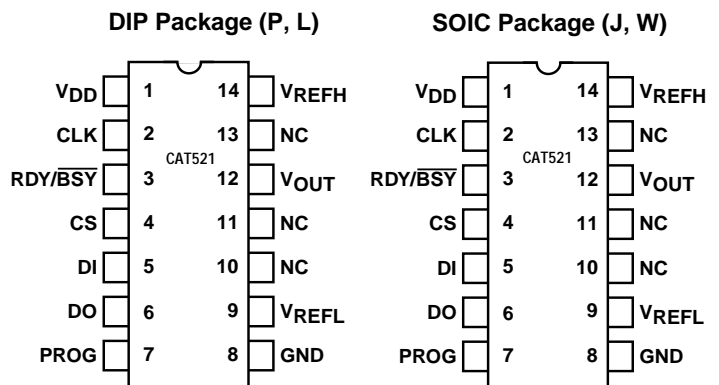

ABSOLUTE MAXIMUM RATINGS

Supply Voltage*
 V_{DD} to GND -0.5V to +7V

Inputs
 CLK to GND -0.5V to $V_{DD} + 0.5V$
 CS to GND -0.5V to $V_{DD} + 0.5V$
 DI to GND -0.5V to $V_{DD} + 0.5V$
 RDY/BSY to GND -0.5V to $V_{DD} + 0.5V$
 PROG to GND -0.5V to $V_{DD} + 0.5V$
 V_{REFH} to GND -0.5V to $V_{DD} + 0.5V$
 V_{REFL} to GND -0.5V to $V_{DD} + 0.5V$

Outputs
 D_0 to GND -0.5V to $V_{DD} + 0.5V$
 V_{OUT} 1– 4 to GND -0.5V to $V_{DD} + 0.5V$

Operating Ambient Temperature

Commercial ('C' or Blank suffix) 0°C to +70°C
 Industrial ('I' suffix) -40°C to +85°C
 Junction Temperature +150°C
 Storage Temperature -65°C to +150°C
 Lead Soldering (10 sec max) +300°C

* Stresses above those listed under Absolute Maximum Ratings may cause permanent damage to the device. Absolute Maximum Ratings are limited values applied individually while other parameters are within specified operating conditions, and functional operation at any of these conditions is NOT implied. Device performance and reliability may be impaired by exposure to absolute rating conditions for extended periods of time.

RELIABILITY CHARACTERISTICS

Symbol	Parameter	Min	Max	Units	Test Method
$V_{ZAP}^{(1)}$	ESD Susceptibility	2000		Volts	MIL-STD-883, Test Method 3015
$I_{LTH}^{(1)(2)}$	Latch-Up	100		mA	JEDEC Standard 17

- NOTES:** 1. This parameter is tested initially and after a design or process change that affects the parameter.
 2. Latch-up protection is provided for stresses up to 100mA on address and data pins from -1V to $V_{CC} + 1V$.

POWER SUPPLY

Symbol	Parameter	Conditions	Min	Typ	Max	Units
I_{DD1}	Supply Current (Read)	Normal Operating	—	400	600	μA
I_{DD2}	Supply Current (Write)	Programming, $V_{DD} = 5V$	—	1600	2500	μA
		$V_{DD} = 3V$	—	1000	1600	μA
V_{DD}	Operating Voltage Range		2.7	—	5.5	V

LOGIC INPUTS

Symbol	Parameter	Conditions	Min	Typ	Max	Units
I_{IH}	Input Leakage Current	$V_{IN} = V_{DD}$	—	—	10	μA
I_{IL}	Input Leakage Current	$V_{IN} = 0V$	—	—	-10	μA
V_{IH}	High Level Input Voltage		2	—	V_{DD}	V
V_{IL}	Low Level Input Voltage		0	—	0.8	V

LOGIC OUTPUTS

Symbol	Parameter	Conditions	Min	Typ	Max	Units
V_{OH}	High Level Output Voltage	$I_{OH} = -40\mu A$	$V_{DD} - 0.3$	—	—	V
V_{IL}	Low Level Output Voltage	$I_{OL} = 1\text{ mA}, V_{DD} = +5V$	—	—	0.4	V
		$I_{OL} = 0.4\text{ mA}, V_{DD} = +3V$	—	—	0.4	V

POTENTIOMETER CHARACTERISTICS
 $V_{DD} = +2.7V$ to $+5.5V$, $V_{REFH} = V_{DD}$, $V_{REFL} = 0V$, unless otherwise specified

Symbol	Parameter	Conditions	Min	Typ	Max	Units
R_{POT}	Potentiometer Resistance	See Note 3		24		$k\Omega$
	R_{POT} to R_{POT} Match		—	± 0.5	± 1	%
	Pot Resistance Tolerance				± 20	%
	Voltage on V_{REFH} pin		2.7		V_{DD}	V
	Voltage on V_{REFL} pin		0V		$V_{DD} - 2.7$	V
	Resolution			0.4		%
INL	Integral Linearity Error			0.5	1	LSB
DNL	Differential Linearity Error			0.25	0.5	LSB
R_{OUT}	Buffer Output Resistance				10	Ω
I_{OUT}	Buffer Output Current				3	mA
TC_{RPOT}	TC of Pot Resistance			300		ppm/ $^{\circ}C$
C_H/C_L	Potentiometer Capacitances			8/8		pF

AC ELECTRICAL CHARACTERISTICS:
 $V_{DD} = +2.7V$ to $+5.5V$, $V_{REFH} = V_{DD}$, $V_{REFL} = 0V$, unless otherwise specified

Symbol	Parameter	Conditions	Min	Typ	Max	Units
Digital						
t_{CSMIN}	Minimum CS Low Time		150	—	—	ns
t_{CSS}	CS Setup Time		100	—	—	ns
t_{CSH}	CS Hold Time	$C_L = 100pF$, see note 1	0	—	—	ns
t_{DIS}	DI Setup Time		50	—	—	ns
t_{DIH}	DI Hold Time		50	—	—	ns
t_{DO1}	Output Delay to 1		—	—	150	ns
t_{DO0}	Output Delay to 0		—	—	150	ns
t_{HZ}	Output Delay to High-Z			—	400	—
t_{LZ}	Output Delay to Low-Z		—	400	—	ns
t_{BUSY}	Erase/Write Cycle Time		—	4	5	ms
t_{PS}	PROG Setup Time		150	—	—	ns
t_{PROG}	Minimum Pulse Width		700	—	—	ns
t_{CLKH}	Minimum CLK High Time		500	—	—	ns
t_{CLKL}	Minimum CLK Low Time		300	—	—	ns
f_C	Clock Frequency		DC	—	1	MHz
Analog						
t_{DS}	DPP Settling Time to 1 LSB	$C_{LOAD} = 10 pF, V_{DD} = +5V$	—	3	10	μs
		$C_{LOAD} = 10 pF, V_{DD} = +3V$	—	6	10	μs

NOTES:

- All timing measurements are defined at the point of signal crossing $V_{DD} / 2$.
- These parameters are periodically sampled and are not 100% tested.
- The $24k\Omega \pm 20\%$ resistors are configured as 4 resistors in parallel which would provide a measured value between V_{REFH} and V_{REFL} of $6k\Omega \pm 20\%$. The individual $24k\Omega$ resistors are not measurable but guaranteed by design and verification of the $6k\Omega \pm 20\%$ value.

A. C. TIMING DIAGRAM

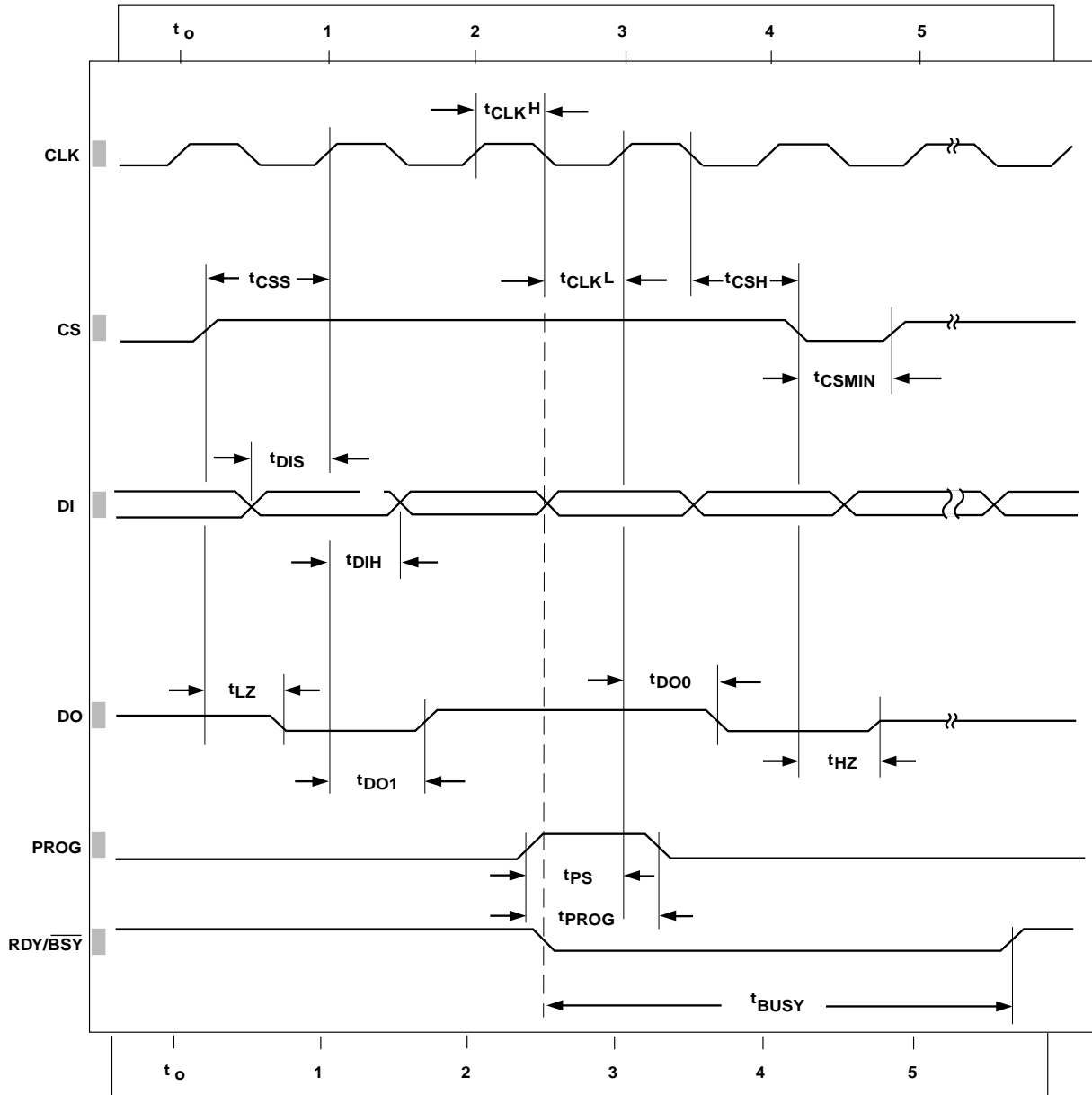

PIN DESCRIPTION

Pin	Name	Function
1	V _{DD}	Power supply positive
2	CLK	Clock input pin
3	RDY/ $\overline{\text{BSY}}$	Ready/Busy output
4	CS	Chip select
5	DI	Serial data input pin
6	DO	Serial data output pin
7	PROG	EEPROM Programming Enable Input
8	GND	Power supply ground
9	V _{REFL}	Minimum DAC output voltage
10	NC	No Connect
11	NC	No Connect
12	V _{OUT}	DPP output
13	NC	No Connect
14	V _{REFH}	Maximum DPP 1 output voltage

DPP addressing is as follows:

DPP OUTPUT	A0	A1
V _{OUT}	1	0

DEVICE OPERATION

The CAT521 is a single 8-bit configured digitally programmable potentiometer (DPP™) whose output can be programmed to any one of 256 individual voltage steps. Once programmed, the output setting is retained in non-volatile memory and will not be lost when power is removed from the chip. Upon power up the DPP returns to the setting stored in non-volatile memory. The DPP can be written to and read from without effecting the output voltage during the read or write cycle. The output can also be adjusted without altering the stored output setting, which is useful for testing new output settings before storing them in memory.

DIGITAL INTERFACE

The CAT521 employs a 3 wire, Microwire-like serial control interface consisting of Clock (CLK), Chip Select (CS) and Data In (DI) inputs. For all operations, address and data are shifted in LSB first. In addition, all digital data must be preceded by a logic "1" as a start bit. The DPP address and data are clocked into the DI pin on the clock's rising edge. When sending multiple blocks of information a minimum of two clock cycles is required between the last block sent and the next start bit.

Multiple devices may share a common input data line by selectively activating the CS control of the desired IC. Data Outputs (DO) can also share a common line because the DO pin is Tri-States and returns to a high impedance when not in use.

CHIP SELECT

Chip Select (CS) enables and disables the CAT521's read and write operations. When CS is high data may be read to or from the chip, and the Data Output (DO) pin is active. Data loaded into the DPP control register will remain in effect until CS goes low. Bringing CS to a logic low returns all DPP outputs to the settings stored in non-volatile memory and switches DO to its high impedance Tri-State mode.

Because CS functions like a reset the CS pin has been desensitized with a 30 ns to 90 ns filter circuit to prevent noise spikes from causing unwanted resets and the loss of volatile data.

CLOCK

The CAT521 clock controls both data flow in and out of the device and non-volatile memory cell programming. Serial data is shifted into the DI pin and out of the DO pin on the clock's rising edge. While it is not necessary for the clock to be running between data transfers, the clock must be operating in order to write to non-volatile memory, even though the data being saved may already be resident in the DPP wiper control register.

No clock is necessary upon system power-up. The CAT521 internal power-on reset circuitry loads data from non-volatile memory to the DPP without using the external clock.

As data transfers are edge triggered clean clock transitions are necessary to avoid falsely clocking data into the control register. Standard CMOS and TTL logic families work well in this regard and it is recommended that any mechanical switches used for breadboarding or device evaluation purposes be debounced by a flip-flop or other suitable debouncing circuit.

V_{REF}

V_{REF}, the voltage applied between pins V_{REFH} & V_{REFL}, sets the DPP's Zero to Full Scale output range where V_{REFL} = Zero and V_{REFH} = Full Scale. V_{REF} can span the full power supply range or just a fraction of it. In typical applications V_{REFH} & V_{REFL} are connected across the power supply rails. When using less than the full supply voltage be mindfull of the limits placed on V_{REFH} and V_{REFL} as specified in the References section of DC Electrical Characteristics.

READY/BSY

When saving data to non-volatile memory, the Ready/Busy output (RDY/BSY) signals the start and duration of the non-volatile erase/write cycle. Upon receiving a command to store data (PROG goes high) RDY/BSY goes low and remains low until the programming cycle is complete. During this time the CAT521 will ignore any data appearing at DI and no data will be output on DO.

RDY/BSY is internally ANDed with a low voltage detector circuit monitoring V_{DD}. If V_{DD} is below the minimum value required for non-volatile programming, RDY/BSY will remain high following the program command indicating a failure to record the desired data in non-volatile memory.

DATA OUTPUT

Data is output serially by the CAT521, LSB first, via the Data Out (DO) pin following the reception of a start bit and two address bits by the Data Input (DI). DO becomes active whenever CS goes high and resumes its high impedance Tri-State mode when CS returns low. Tri-Stating the DO pin allows several 521s to share a

single serial data line and simplifies interfacing multiple 521s to a microprocessor.

WRITING TO MEMORY

Programming the CAT521's non-volatile memory is accomplished through the control signals: Chip Select (CS) and Program (PROG). With CS high, a start bit followed by a two bit DPP address and eight data bits are clocked into the DPP wiper control register via the DI pin. Data enters on the clock's rising edge. The DPP output changes to its new setting on the clock cycle following D7, the last data bit.

Programming is accomplished by bringing PROG high sometime after the start bit and at least 150 ns prior to the rising edge of the clock cycle immediately following the D7 bit. Two clock cycles after the D7 bit the DPP wiper control register will be ready to receive the next set of address and data bits. The clock must be kept running throughout the programming cycle. Internal control circuitry takes care of generating and ramping up the programming voltage for data transfer to the non-volatile memory cells. The CAT521 non-volatile memory cells will endure over 1,000,000 write cycles and will retain data for a minimum of 100 years without being refreshed.

READING DATA

Each time data is transferred into the DPP wiper control register currently held data is shifted out via the D0 pin, thus in every data transaction a read cycle occurs. Note, however, that the reading process is destructive. Data must be removed from the register in order to be read. Figure 2 depicts a Read Only cycle in which no change occurs in the DPP's output. This feature allows μ Ps to poll DPPs for their current setting without disturbing the output voltage but it assumes that the setting being read is also stored in non-volatile memory so that it can be restored at the end of the read cycle. In Figure 2 CS returns low before the 13th clock cycle completes. In doing so the non-volatile memory's setting is reloaded into the DPP wiper control register. Since this value is

Figure 1. Writing to Memory

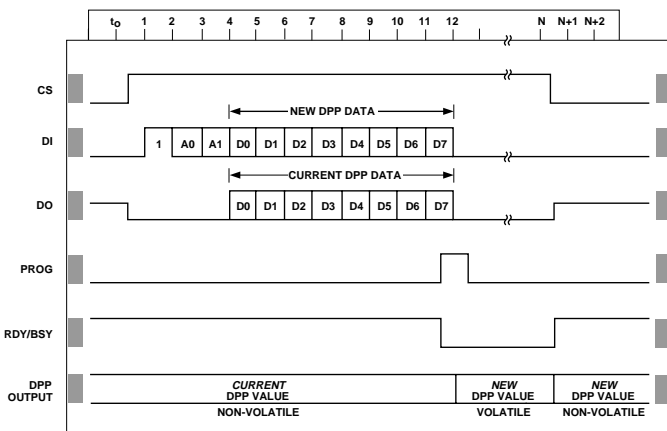
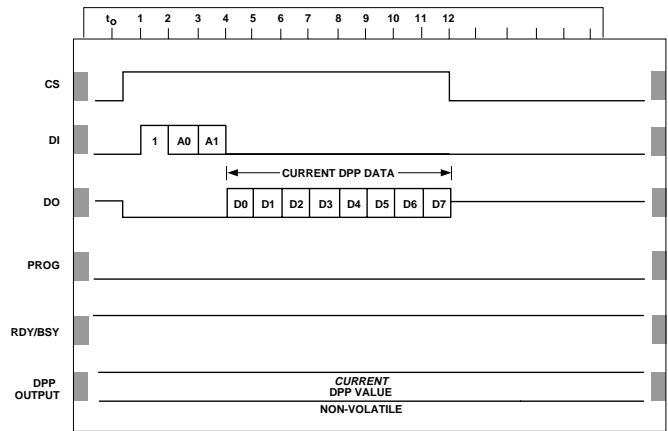

Figure 2. Reading from Memory



the same as that which had been there previously no change in the DPP's output is noticed. Had the value held in the control register been different from that stored in non-volatile memory then a *change would occur* at the read cycle's conclusion.

TEMPORARILY CHANGE OUTPUT

The CAT521 allows temporary changes in the DPP's output to be made without disturbing the settings retained in non-volatile memory. This feature is particularly useful when testing for a new output setting and allows for user adjustment of preset or default values without losing the original factory settings.

Figure 3 shows the control and data signals needed to effect a temporary output change. DPP settings may be changed as many times as required. The temporary setting remains in effect long as CS remains high. When CS returns low the DPP will return to the output value stored in non-volatile memory.

When it is desired to save a new setting acquired using this feature, the new value must be reloaded into the DPP wiper control register prior to programming. This is because the CAT521's internal control circuitry discards from the programming register the new data two clock cycles after receiving it if no PROG signal is received.

Figure 3. Temporary Change in Output

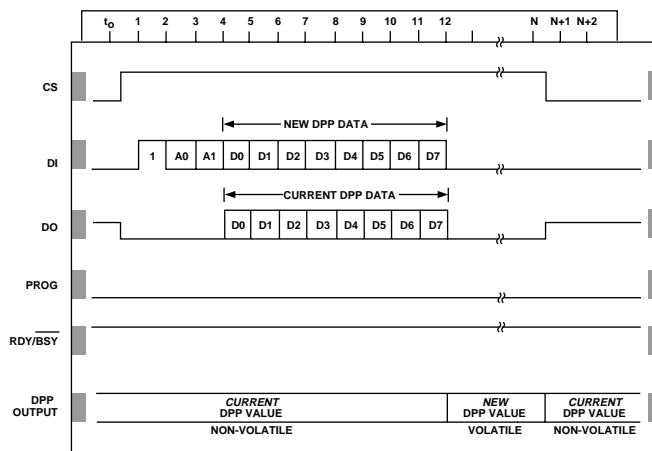

APPLICATION CIRCUITS

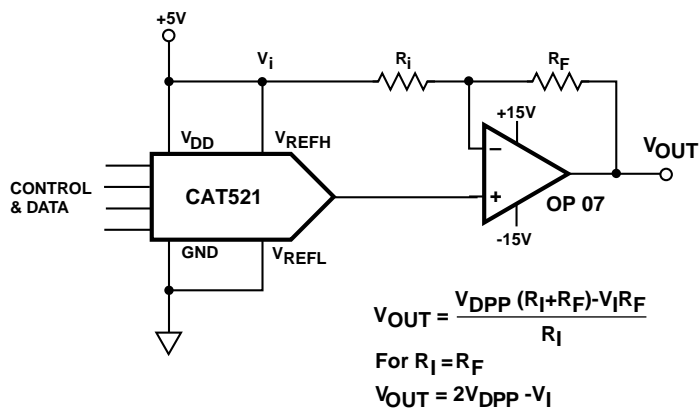

DPP INPUT		DPP OUTPUT		ANALOG OUTPUT
MSB	LSB	$V_{DPP} = \frac{CODE}{255} (V_{FS} - V_{ZERO}) + V_{ZERO}$		
		$V_{FS} = 0.99 V$		$V_{REF} = 5V$ $R_I = R_F$
		$V_{ZERO} = 0.01 V$		
1111	1111	$\frac{255}{255} (.98 V_{REF}) + .01 V_{REF} = .990 V_{REF}$		$V_{OUT} = +4.90V$
1000	0000	$\frac{128}{255} (.98 V_{REF}) + .01 V_{REF} = .502 V_{REF}$		$V_{OUT} = +0.02V$
0111	1111	$\frac{127}{255} (.98 V_{REF}) + .01 V_{REF} = .498 V_{REF}$		$V_{OUT} = -0.02V$
0000	0001	$\frac{1}{255} (.98 V_{REF}) + .01 V_{REF} = .014 V_{REF}$		$V_{OUT} = -4.86V$
0000	0000	$\frac{0}{255} (.98 V_{REF}) + .01 V_{REF} = .010 V_{REF}$		$V_{OUT} = -4.90V$

Bipolar DPP Output

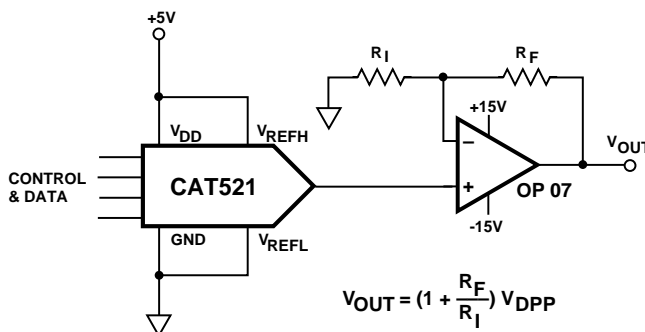

Amplified DPP Output

APPLICATION CIRCUITS (Cont.)

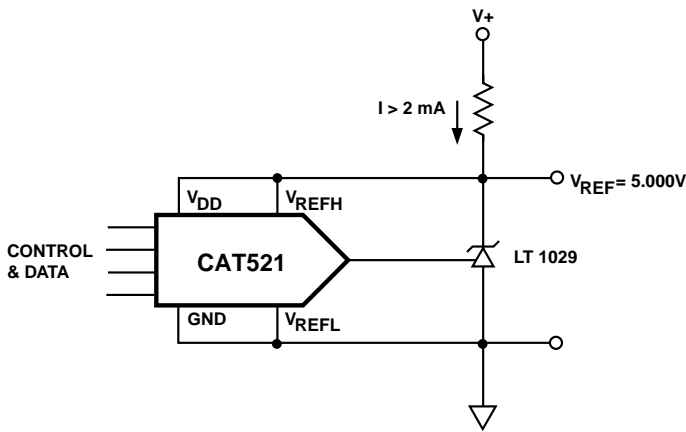

Digitally Trimmed Voltage Reference

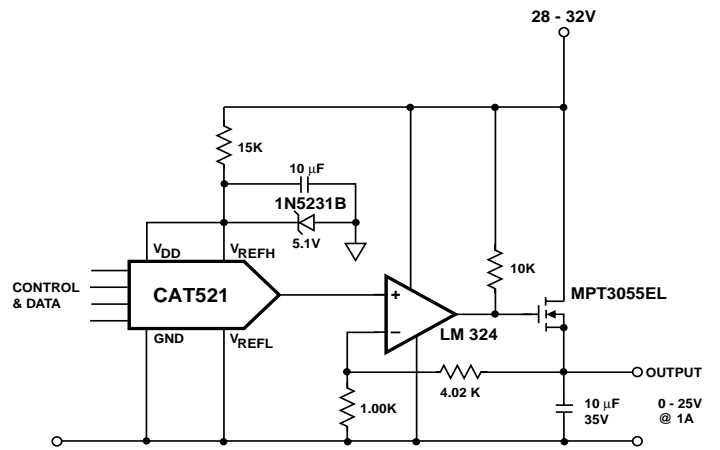

Digitally Controlled Voltage Reference

ORDERING INFORMATION

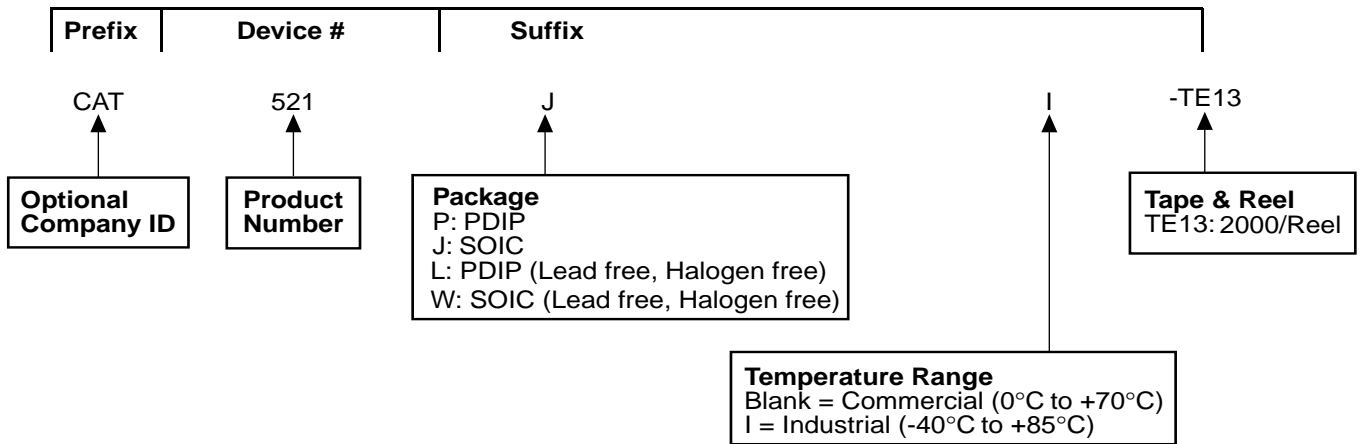

Notes:

(1) The device used in the above example is a CAT521JI-TE13 (SOIC, Industrial Temperature, Tape & Reel)

REVISION HISTORY

Date	Rev.	Reason
3/16/2004	E	Updated Potentiometer Characteristics
7/12/2004	F	Updated Functional Diagram Updated Potentiometre Characteristics Added Note 3 under Potentiometer/AC Characteristics tables

Copyrights, Trademarks and Patents

Trademarks and registered trademarks of Catalyst Semiconductor include each of the following:

DPP™ AE²™

Catalyst Semiconductor has been issued U.S. and foreign patents and has patent applications pending that protect its products. For a complete list of patents issued to Catalyst Semiconductor contact the Company's corporate office at 408.542.1000.

CATALYST SEMICONDUCTOR MAKES NO WARRANTY, REPRESENTATION OR GUARANTEE, EXPRESS OR IMPLIED, REGARDING THE SUITABILITY OF ITS PRODUCTS FOR ANY PARTICULAR PURPOSE, NOR THAT THE USE OF ITS PRODUCTS WILL NOT INFRINGE ITS INTELLECTUAL PROPERTY RIGHTS OR THE RIGHTS OF THIRD PARTIES WITH RESPECT TO ANY PARTICULAR USE OR APPLICATION AND SPECIFICALLY DISCLAIMS ANY AND ALL LIABILITY ARISING OUT OF ANY SUCH USE OR APPLICATION, INCLUDING BUT NOT LIMITED TO, CONSEQUENTIAL OR INCIDENTAL DAMAGES.

Catalyst Semiconductor products are not designed, intended, or authorized for use as components in systems intended for surgical implant into the body, or other applications intended to support or sustain life, or for any other application in which the failure of the Catalyst Semiconductor product could create a situation where personal injury or death may occur.

Catalyst Semiconductor reserves the right to make changes to or discontinue any product or service described herein without notice. Products with data sheets labeled "Advance Information" or "Preliminary" and other products described herein may not be in production or offered for sale.

Catalyst Semiconductor advises customers to obtain the current version of the relevant product information before placing orders. Circuit diagrams illustrate typical semiconductor applications and may not be complete.



CATALYST

Catalyst Semiconductor, Inc.
Corporate Headquarters
1250 Borregas Avenue
Sunnyvale, CA 94089
Phone: 408.542.1000
Fax: 408.542.1200
www.catsemi.com

Publication #: 2003
Revision: F
Issue date: 7/12/04
Type: Final