

XC612 Series



2-Channel Voltage Detectors

- ◆ CMOS Low Power Consumption
- ◆ 2 Voltage Detectors Built-in
- ◆ Detect Voltage Accuracy : $\pm 2\%$
- ◆ Detect Voltage Range : 1.5V ~ 5.0V
- ◆ SOT-25 Package

GENERAL DESCRIPTION

The XC612 series consist of 2 voltage detectors, in 1 mini-molded, SOT-25 package.

The series provides accuracy and low power consumption through CMOS processing and laser trimming and consists of a highly accurate voltage reference source, 2 comparators, hysteresis and output driver circuits.

The input (V_{IN1}) for voltage detector 1 (V_{D1}) dually functions as the power supply pin for both detector 1 (V_{D1}) and detector 2 (V_{D2}).

APPLICATIONS

- Microprocessor reset circuitry
- Memory battery back-up circuits
- Power-on reset circuits
- Power failure detection
- System battery life and charge voltage monitors
- Delay circuitry

FEATURES

- Highly Accurate** : Setting voltage accuracy $\pm 2\%$
- Low Power Consumption** : $2.0 \mu A$ (TYP.)
($V_{IN1}=V_{IN2}=2.0V$, Static state)
- Detect Voltage** : 1.5V ~ 5.0V programmable in 100mV steps. Detector's voltages can be set-up independently Conditionally;
XC612N : $V_{DET1} > V_{DET2}$
XC612D, XC612E : $V_{DET1} \geq V_{DET2}$,
 $V_{DET1} < V_{DET2}$
- Operating Voltage Range** : 1.5V ~ 10.0V
- Temperature Characteristics** : $\pm 100 \text{ppm}/^\circ\text{C}$ (TYP.)
- Output Configuration** : N-channel open drain
- Small Package** : SOT-25 (150mW) mini-mold
- * CMOS Output is under development

TYPICAL APPLICATION CRICUIT

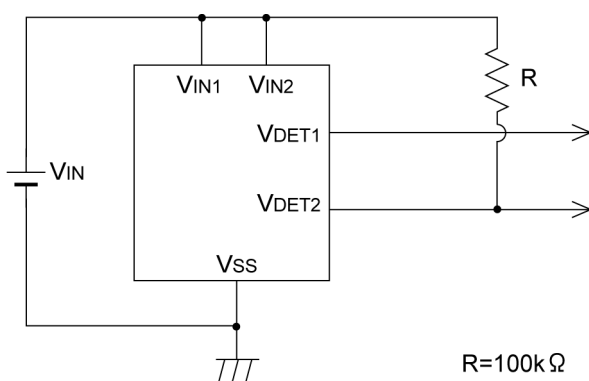

V_{DET1} : CMOS, V_{DET2} : N-ch Open drain

TYPICAL PERFORMANCE CHARACTERISTICS

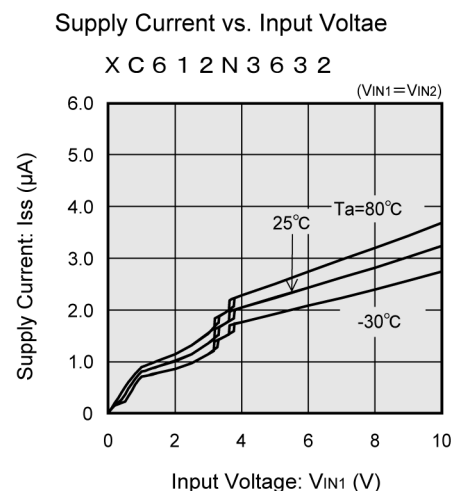

■ PIN CONFIGURATION

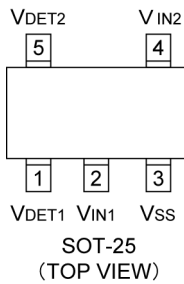

■ PIN ASSIGNMENT

PIN NUMBER	PIN NAME	FUNCTION
1	VDET1	Voltage Detector 1 Output
2	VIN1	Detector 1 Input, Power Supply
3	VSS	Ground
4	VIN2	Voltage Detector 2 Input
5	VDET2	Voltage Detector 2 Output

■ PRODUCT CLASSIFICATION

● Selection Guide

TYPE	VDET1	VDET2
XC612N	N-ch Open Drain	N-ch Open Drain
XC612D	N-ch Open Drain	CMOS
XC612E	CMOS	N-ch Open Drain

● Ordering Information

XC612①②③④⑤⑥⑦

DESIGNATOR	DESCRIPTION	SYMBOL	DESCRIPTION
①	Output Configuration	N	: VDET1/VDET2: N-ch open drain
		D	: VDET1: N-ch open drain, VDET2: CMOS
		E	: VDET1: CMOS, VDET2: N-ch open drain
②③	Detect Voltage 1 (VDET1)	15~50	: VDET1: 2.5V→②25
④⑤	Detect Voltage 2 (VDET2)	15~50	: VDET2: 3.3V→③33
⑥	Package	M	: SOT-25 (SOT-23-5)
⑦	Device Orientation	R	: Embossed tape, standard feed
		L	: Embossed tape, reverse feed

PACKAGING INFORMATION

● SOT-25

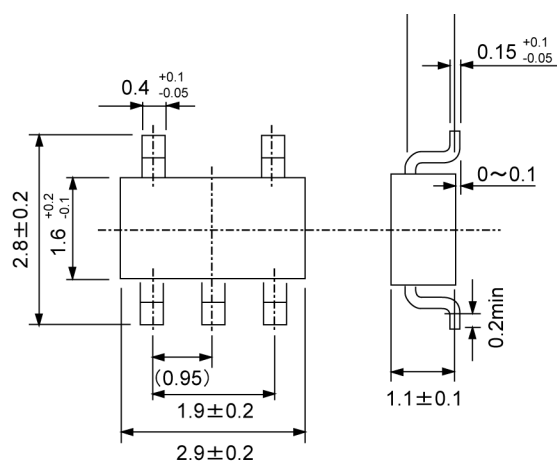

MARKING RULE

● SOT-25

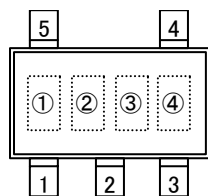

SOT-25
(TOP VIEW)

① Represents output configuration

MARK	CONFIGURATION		PRODUCT SERIES
	VDET1	VDET2	
<u>N</u>	N-ch Open Drain	N-ch Open Drain	XC612NxxxxMx
<u>D</u>	N-ch Open Drain	CMOS	XC612DxxxxMx
<u>E</u>	CMOS	N-ch Open Drain	XC612ExxxxMx

②, ③ Represents sequence number

④ Represents production lot number
0 to 9, A to Z repeated. (G, I, J, O, Q, W excepted.)

■ BLOCK DIAGRAMS

XC612N Series

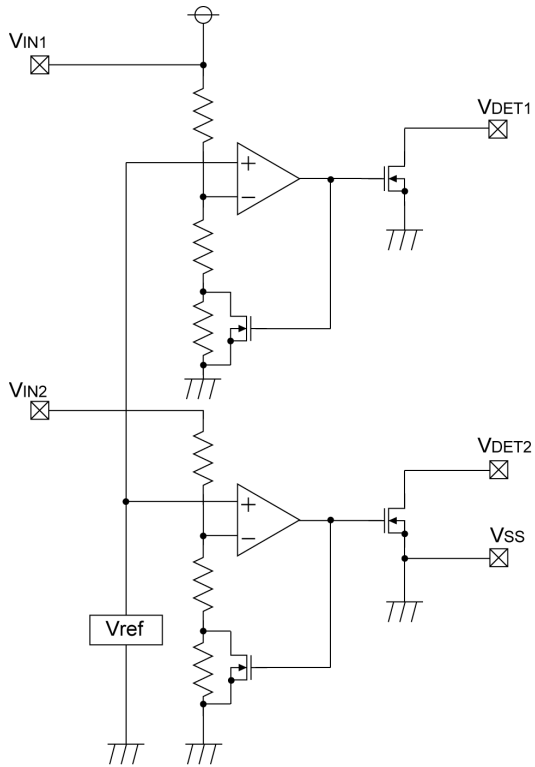

XC612D Series

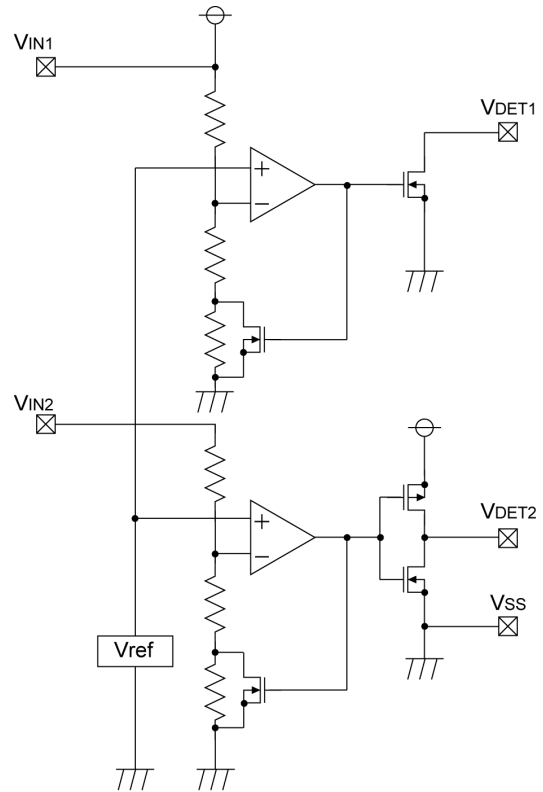

XC612E Series

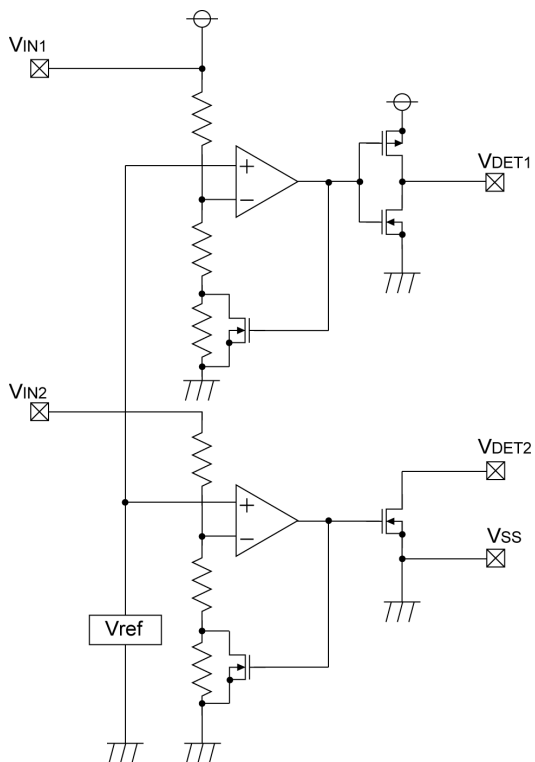

■ ABSOLUTE MAXIMUM RATINGS

Ta = 25°C

PARAMETER	SYMBOL	RATINGS	UNITS	
Input Voltage	V _{D 1}	V _{IN1}	12.0	V
	V _{D 2}	V _{IN2}	12.0	V
Output Voltage	V _{D 1} (N-ch open drain)	V _{VDET1}	V _{SS} – 0.3 ~ 12.0	V
	V _{D 1} (CMOS)		V _{SS} – 0.3 ~ V _{IN1} + 0.3	V
	V _{D 2} (N-ch open drain)	V _{VDET2}	V _{SS} – 0.3 ~ 12.0	V
	V _{D 2} (CMOS)		V _{SS} – 0.3 ~ V _{IN1} + 0.3	V
Output Current	V _{D 1}	I _{VDET1}	50	mA
	V _{D 2}	I _{VDET2}	50	mA
Power Dissipation		P _d	150	mW
Operating Temperature Range		T _{opr}	- 30 ~ + 80	°C
Storage Temperature Range		T _{stg}	- 40 ~ + 125	°C

ELECTRICAL CHARACTERISTICS

Ta=25°C

PARAMETER	SYMBOL	CONDITIONS	MIN.	TYP.	MAX.	UNITS	CIRCUIT	
Detect Voltage (V _{DET1}) (*1)	V _{DF1}	Voltage when V _{DET1} changes from H to L following a reduction of V _{IN1}	V _{DF1} x 0.98	V _{DF1}	V _{DF1} x 1.02	V	1	
Detect Voltage (V _{DET2}) (*1)	V _{DF2}	Voltage when V _{DET2} changes from H to L following a reduction of V _{IN2}	V _{DF2} x 0.98	V _{DF2}	V _{DF2} x 1.02	V	1	
Hysteresis Range 1	V _{HYS1}	Voltage (V _{DR1}) - V _{DF1} when V _{DET1} changes from L to H following an increase of V _{IN1}	V _{DF1(T)} x 0.02	V _{DF1(T)} x 0.05	V _{DF1(T)} x 0.08	V	1	
Hysteresis Range 2	V _{HYS2}	Voltage (V _{DR2}) - V _{DF2} when V _{DET2} changes from L to H following an increase of V _{IN2}	V _{DF2(T)} x 0.02	V _{DF2(T)} x 0.05	V _{DF2(T)} x 0.08	V	1	
Supply Current (V _{IN1} Input Current)	I _{SS}	V _{IN1} = 1.5V	-	1.35	3.90	μA	2	
		V _{IN1} = 2.0V	-	1.50	4.50			
		V _{IN1} = 3.0V	-	1.95	5.10			
		V _{IN1} = 4.0V	-	2.40	5.70			
		V _{IN1} = 5.0V	-	3.00	6.30			
V _{IN2} Input Current	I _{IN2}	V _{IN2} = 1.5V	-	0.45	1.30	μA	2	
		V _{IN2} = 2.0V	-	0.50	1.50			
		V _{IN2} = 3.0V	-	0.65	1.70			
		V _{IN2} = 4.0V	-	0.80	1.90			
		V _{IN2} = 5.0V	-	1.00	2.10			
Operating Voltage	V _{IN1}	V _{DF(T)} = 1.5V to 6.0V	1.0	-	10	V	-	
Output Current (*3)	I _{VDET}	N-ch, V _{DS} =0.5V	V _{IN1} = 1.0V	0.3	2.2	-	mA	3
			V _{IN1} = 2.0V	3.0	7.7	-		
			V _{IN1} = 3.0V	5.0	10.1	-		
			V _{IN1} = 4.0V	6.0	11.5	-		
			V _{IN1} = 5.0V	7.0	13.0	-		
		P-ch (CMOS) V _{DS} =-2.1V	V _{IN1} = 8.0V	-	-10.0	-2.0		
Temperature Characteristics (*3)	$\frac{\Delta V_{DF}}{\Delta T_{opr} \cdot V_{DF}}$	-30°C ≤ T _{opr} ≤ 80°C	-	±100	-	ppm/°C	-	
Delay Time (*3) (Release Voltage→ Output inversion)	t _{DLY}	(V _{DR} →V _{OUT} inversion)	-	-	0.2	ms	5	

NOTE:

*1 : V_{DF1(T)}, V_{DF2(T)} : User specified detect voltage.

*2 : Release voltage (V_{DR}) = V_{DF} + V_{HYS}

*3 : Those parameters marked with an asterisk apply to both V_{DET1} and V_{DET2}.

*4 : Input Voltage : please ensure that V_{IN1} > V_{IN2}

(Input voltage of XC612D and XC612E series : please ensure that V_{IN1} ≥ V_{IN2}, V_{IN1} < V_{IN2}.)

*5 : V_{IN1} pin serve both I_{SS} and power supply pin so that V_{IN2} operates V_{IN1} as a power supply source. For normal operation of V_{IN2}, operating voltage higher than the minimum is needed to be applied to power supply pin V_{IN1}.

*6 : For CMOS output products, high level output voltage which is generated when the transient response is released becomes input voltage of V_{IN}.

OPERATIONAL EXPLANATION

●Timing Chart (Pull up voltage =Input voltage V_{IN1})

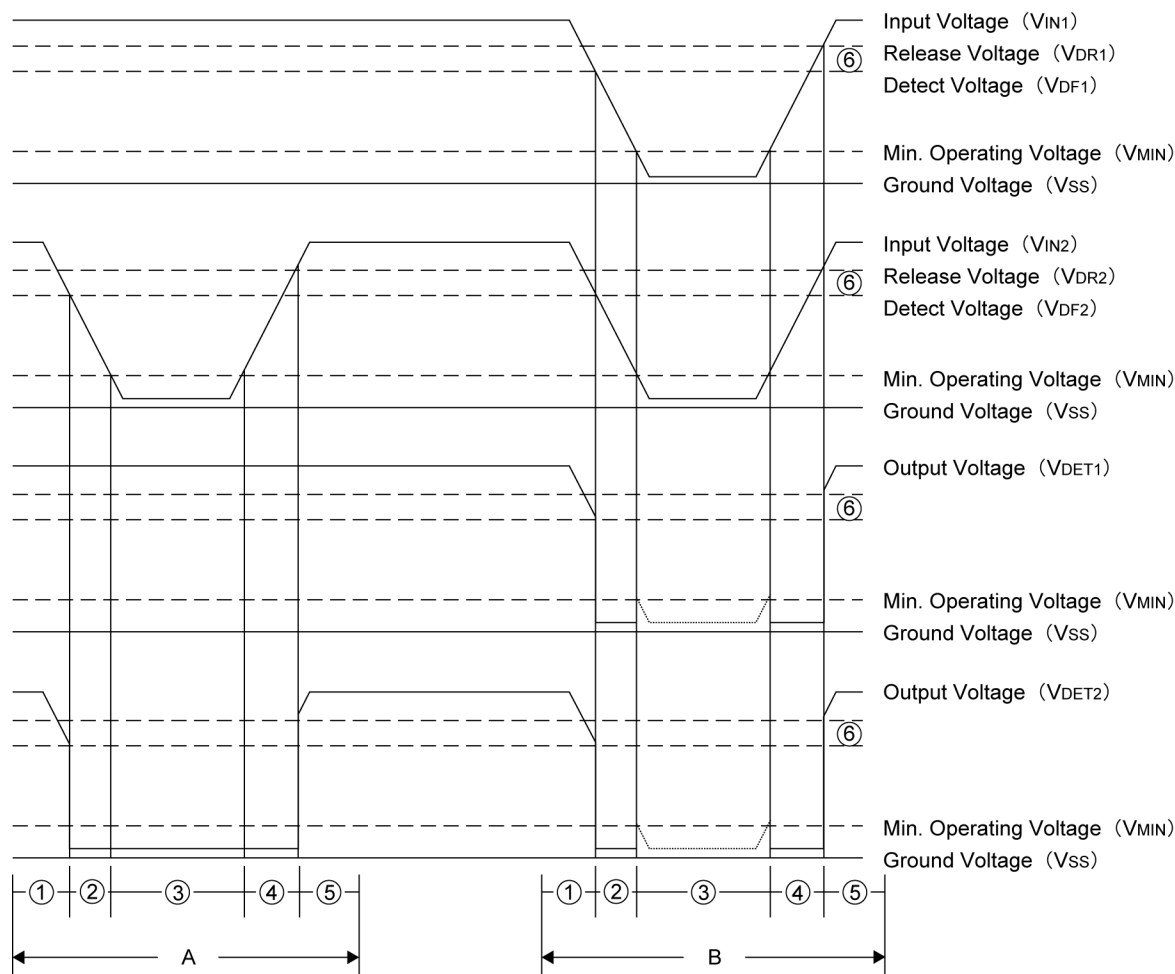

●Operational Notes (N-ch Open drain)

Timing Chart A (V_{IN1} =voltages above release voltage, V_{IN2} =sweep voltage)

Because a voltage higher than the minimum operating voltage is applied to the voltage input pin (V_{IN}), ground voltage will be output at the output pin (V_{DET}) during stage 3. (Stages 1, 2, 4, 5 are the same as in B below).

Timing Chart B ($V_{IN1}=V_{IN2}$)

- ① When a voltage greater than the release voltage (V_{DR}) is applied to the voltage input pin (V_{IN1} , V_{IN2}), input voltage (V_{IN1} , V_{IN2}) will gradually fall.
When a voltage greater than the detect voltage (V_{DF}) is applied to the voltage input pin (V_{IN1} , V_{IN2}), a state of high impedance will exist at the output pin (V_{DET1} , V_{DET2}), so should the pin be pulled up, voltage will be equal to pull up voltage.
- ② When input voltage (V_{IN1} , V_{IN2}) falls below detect voltage (V_{DF}), output voltage (V_{DET1} , V_{DET2}) will be equal to ground level (V_{SS}).
- ③ Should input voltage (V_{IN1} , V_{IN2}) fall below the minimum operational voltage (V_{MIN}), output will become unstable. Should V_{IN2} fall below V_{MIN} , voltage at the output pin (V_{DET2}) will be equal to ground level (V_{SS}) if the power supply (V_{IN1}) is within the operating voltage range.
*In general the output pin is pulled up so output will be equal to pull up voltage.
- ④ Should input voltage (V_{IN1} , V_{IN2}) rise above ground voltage (V_{SS}), output voltage (V_{DET1} , V_{DET2}) will equal ground level until the release voltage level (V_{DR}) is reached.
- ⑤ When input voltage (V_{IN1} , V_{IN2}) rises above release voltage, the output pin's (V_{DET1} , V_{DET2}) voltage will be equal to the voltage dependent on pull up.

Note : The difference between release voltage (V_{DR}) and detect voltage (V_{DF}) is the Hysteresis Range ⑥.

■ NOTES ON USE

1. Please use this IC within the specified maximum absolute ratings.
2. Please ensure that input voltage V_{IN2} is less than $V_{IN1} + 0.3V$. (refer to N.B. 1 below)
3. With a resistor connected between the V_{IN1} pin and the input, oscillation is liable to occur as a result of through current at the time of release. (refer to N.B. 2 below)
4. With a resistor connected between the V_{IN1} pin and the input, detect and release voltage will rise as a result of the IC's supply current flowing through the V_{IN1} pin.
5. In order to stabilize the IC's operations, please ensure that the V_{IN1} pin's input frequency's rise and fall times are more than 5 msec/V.
6. Should the power supply voltage V_{IN1} exceed 6V, voltage detector 2's detect voltage (V_{DF2}) and the release voltage (V_{DR2}) will shift somewhat.
7. For CMOS output products, high level output voltage which is generated when the transient response is released becomes input voltage of V_{IN} .

● N.B.

1. Voltage detector 2's input voltage (V_{IN2})
An input protect diode is connected from input detector 2's input (V_{IN2}) to input detector 1's input. Therefore, should the voltage applied to V_{IN2} exceed V_{IN1} , current will flow through V_{IN1} via the diode. (refer to diagram1)
2. Oscillation as a result of through current
Since the XC612 series are CMOS ICs, through current will flow when the IC's internal circuit switching operates (during release and detect operations). Consequently, oscillation is liable to occur as a result of drops in voltage at the through current's resistor (R_{IN}) during release voltage operations. (refer to diagram 2)
Since hysteresis exists during detect operations, oscillation is unlikely to occur.

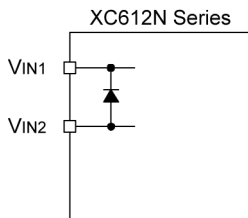

Diagram 1. Voltage detector 2's input voltage V_{IN2}

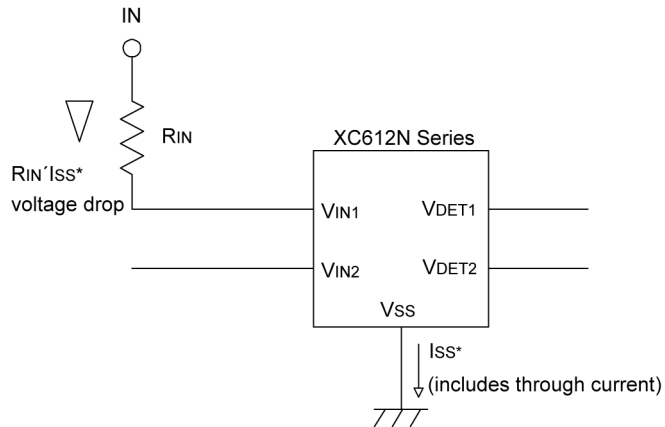
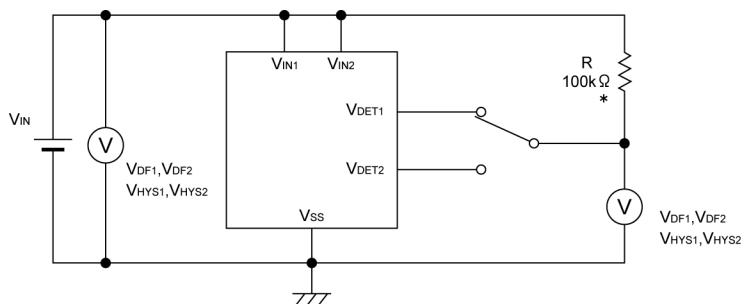

Diagram 2. Through current oscillation

TEST CIRCUITS

Circuit 1



* A resistor is not needed for CMOS output type.

Circuit 2

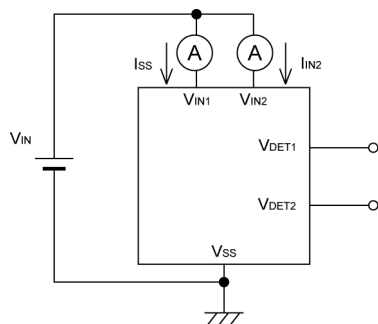

Circuit 3

XC612N Series

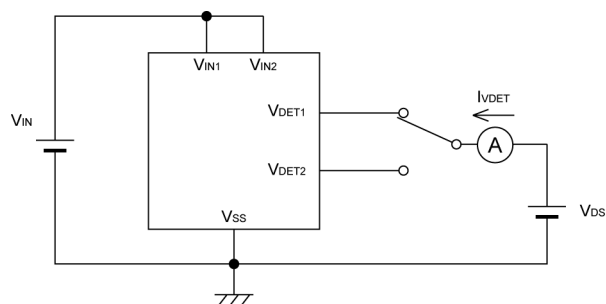

XC612D Series

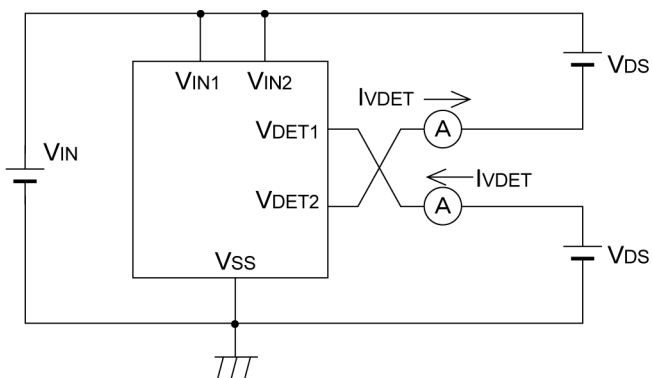

TEST CIRCUITS (Continued)

Circuit 3 (Continued)

XC612E Series

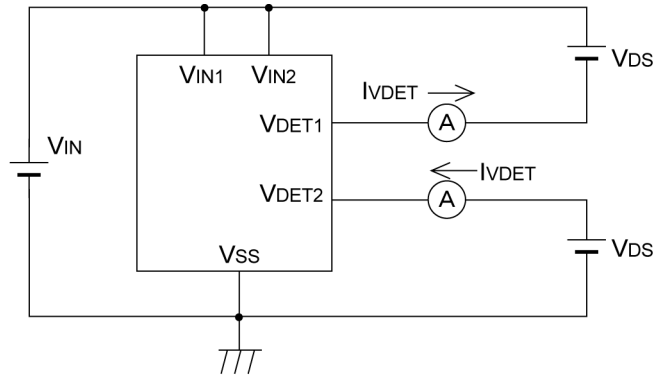

Circuit 4

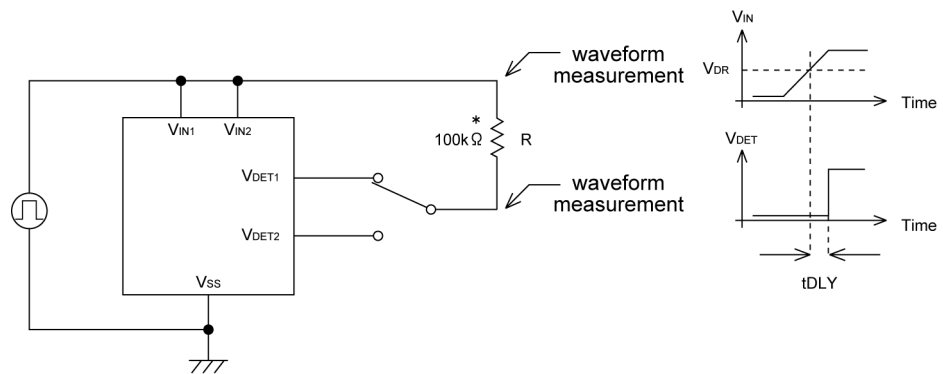

■ TYPICAL PERFORMANCE CHARACTERISTICS

(1) Supply Current vs. Input Voltage

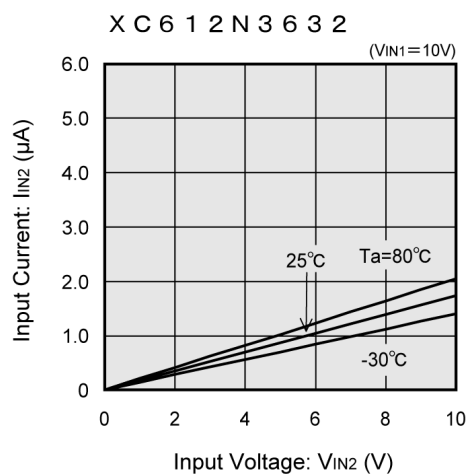
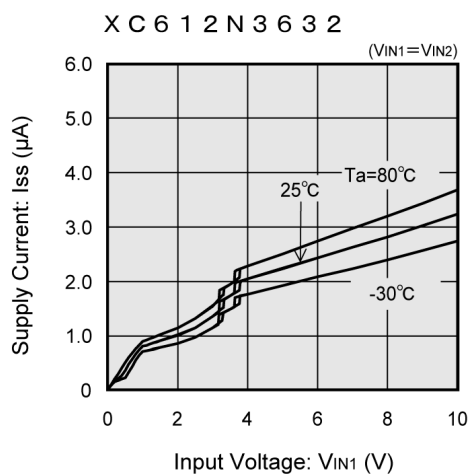

(2) Detect & Release Voltage vs. Ambient Temperature

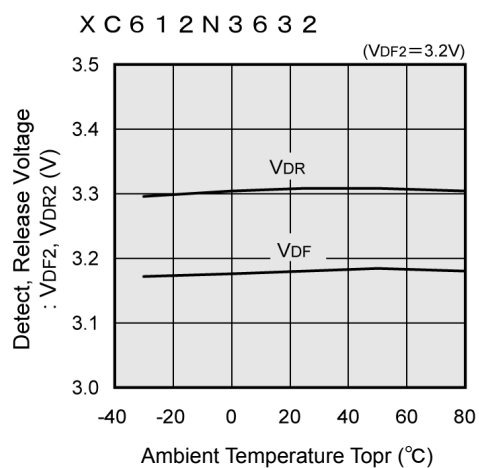
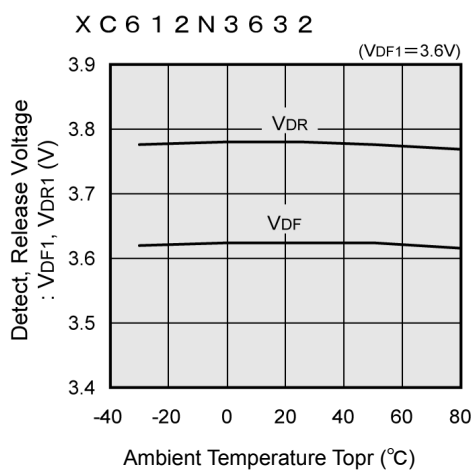

Note: Unless otherwise stated, pull up resistance = 100k Ω with N-ch open drain output type.

(3) Output Voltage vs. Input Voltage

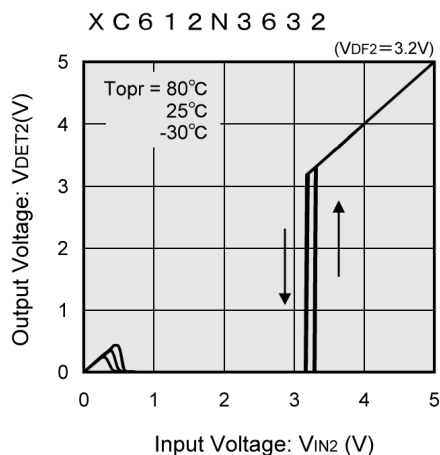
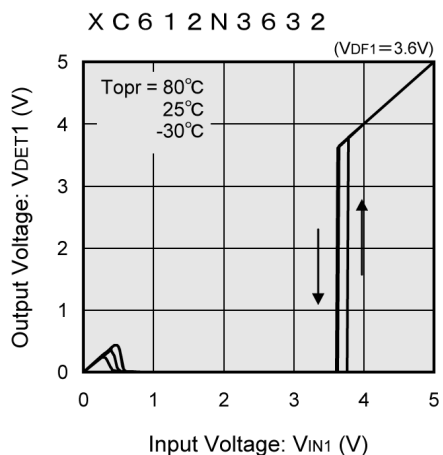

■ TYPICAL PERFORMANCE CHARACTERISTICS (Continued)

(4) N-ch Driver Output Current vs. V_{DS}

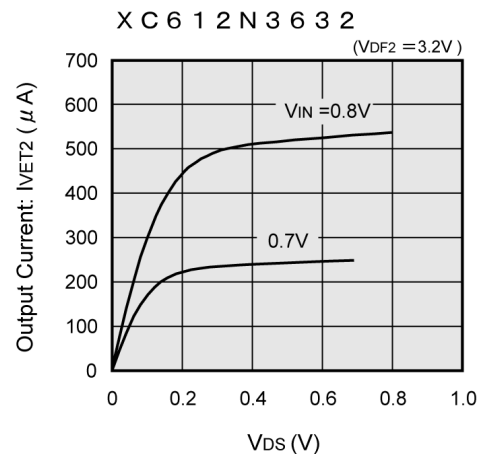
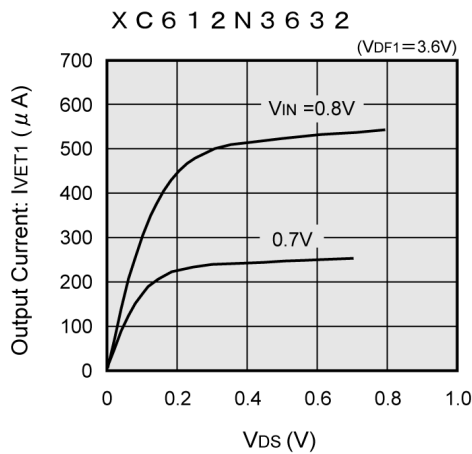
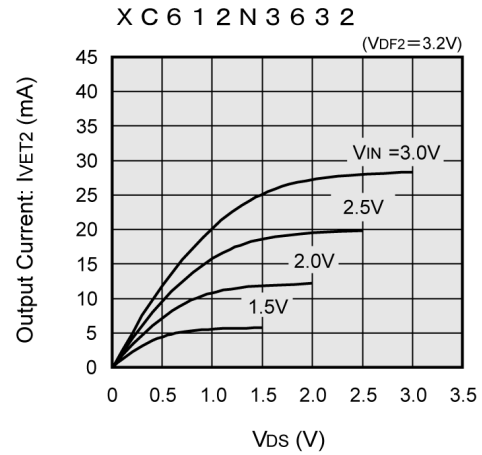
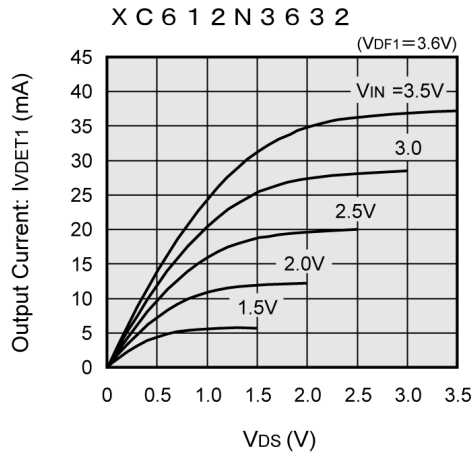

(5) N-ch Driver Output Current vs. Input Voltage

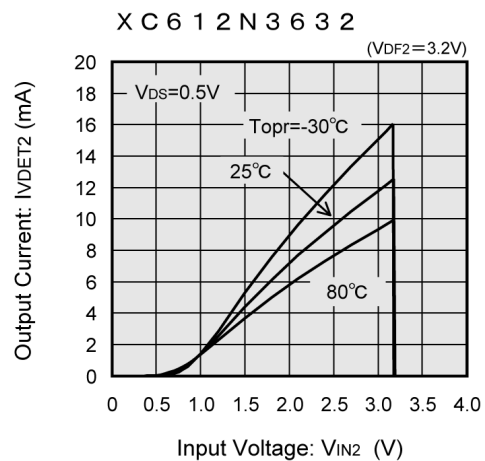
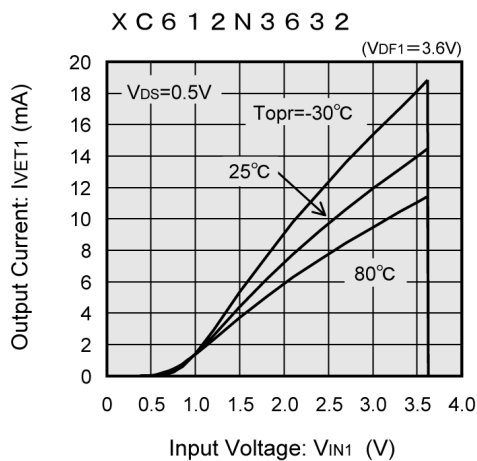

APPLICATION CIRCUITS EXAMPLE *Example covers N-channel open drain product's circuits

● Window comparator circuit

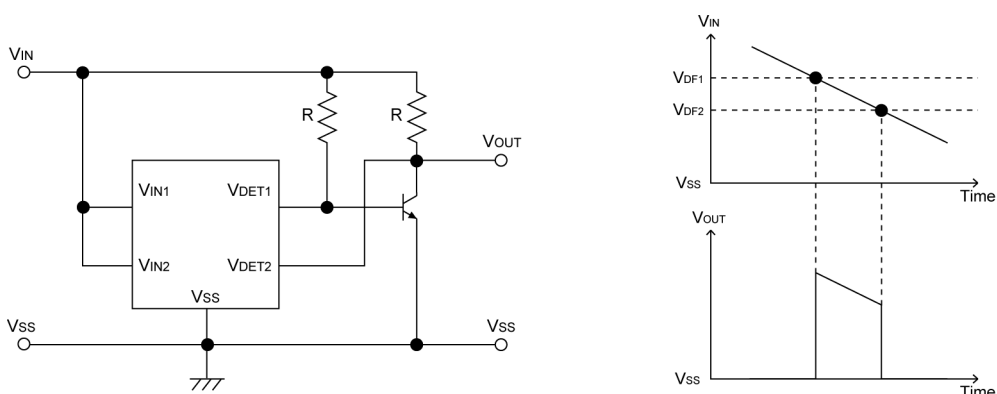

● Detect voltages above respective established voltages circuit

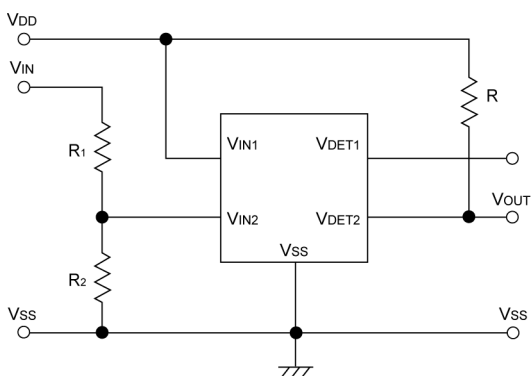

On resistors R1 and R2 equation (1) and (2)

$$\text{Detect voltage} = \{ (R1 + R2) \div R2 \} \times VDF2 \quad (1)$$

N.B. $VDF2$ = detect voltage $VD2$

$$\text{Hysteresis } (VHYS2) = \{ (R1 + R2) \div R2 \} \times VHYS2 \quad (2)$$

Note: Please ensure that input voltage 2 ($VIN2$) is less than $VIN1 + 0.3V$

● Detect voltage circuit with delay built-in

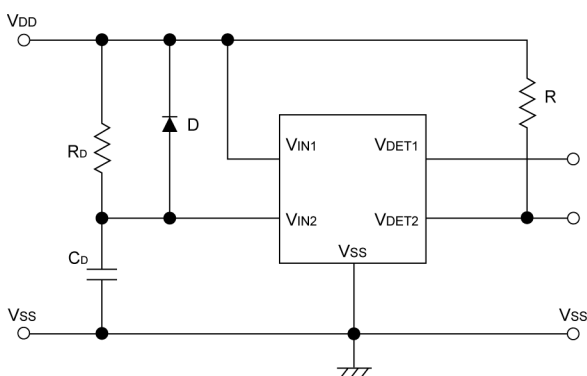

Note: Delay operates at both times of release and detect operations.