

Advanced-Failsafe RS-485/RS-422 Transceiver 1/8th Unit Load, Slew-Limited, $\pm 15\text{kV}$ ESD-Protected

FEATURES

- 5.0V single supply operation
- Receiver failsafe on open, short or terminated lines
- 1/8th Unit Load, 256 transceivers on bus
- Robust ESD protection for RS-485 pins
 - $\pm 15\text{kV}$ Air-Gap Discharge
 - $\pm 15\text{kV}$ Human Body Model
 - $\pm 8\text{kV}$ Contact Discharge
- Controlled driver slew rates
 - 115kbps, Low EMI
- Hot Swap glitch protection on control inputs
- Driver short circuit current limit and thermal shutdown for overload protection
- Ultra-low 300 μA quiescent current
- 650nA shutdown mode
- Industry standard package footprints

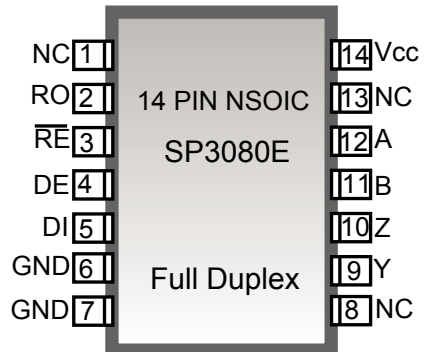

APPLICATIONS

- Motor Control
- Building Automation
- Security Systems
- Remote Meter Reading
- Long or un-terminated transmission lines

DESCRIPTION

The SP3080E is designed for reliable, bidirectional communication on multipoint bus transmission lines. The device contains one differential driver and one differential receiver. The SP3080E is a full-duplex device. All devices comply with TIA/EIA-485 and TIA/EIA-422 standards. Lead-free and RoHS compliant packages are available for all models.

This device is ruggedized for use in harsh operating conditions over the entire common-mode voltage range from -7V to +12V. The receiver is a specially designed to fail-safe to a logic high output state if the inputs are left un-driven or shorted. All RS-485 bus-pins are protected against severe ESD events up to $\pm 15\text{kV}$ (Air-Gap and Human Body Model) and up to $\pm 8\text{kV}$ Contact Discharge (IEC 1000-4-2). The driver is protected from excess current flow caused by bus contention or output short-circuits by both an internal current limit and a thermal-overload shutdown. The device is rated for industrial (-40 to +85°C) or extended (-40 to +125°C) operating temperatures. The receiver has exceptionally high input impedance, which places only 1/8th the standard load on a shared bus. Up to 256 transceivers may coexist while preserving full signal margin.

The device operates from a single 5.0V power supply and draws negligible quiescent power. The SP3080E may independently enable and disable its driver and receiver and enter a low power shutdown mode if both driver and receiver are disabled. The output maintains high impedance in shutdown or when powered-off.

DEVICE ARCHITECTURE AND BLOCK DIAGRAMS

The device is available in industry standard architectures and footprints.

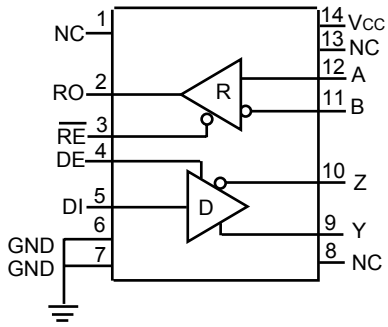

14-Pin Full Duplex

SP3080E, 115kbps slew limited

PIN ASSIGNMENTS

Pin Number	Pin Name	Pin Function
2	RO	Receiver Output. When \overline{RE} is low and if $(A - B) \geq -40\text{mV}$, RO is high. If $(A - B) \leq -200\text{mV}$, RO is low.
3	\overline{RE}	Receiver Output Enable. When \overline{RE} is low, RO is enabled. When \overline{RE} is high, RO is high impedance. Drive RE high and DE low to enter shutdown mode. RE is a hot-swap input.
4	DE	Driver Output Enable. When DE is high, outputs are enabled. When DE is low, outputs are high impedance. Drive DE low and RE high to enter shutdown mode. DE is a hot-swap input.
5	DI	Driver Input. With DE high, a low level on DI forces non-inverting output low and inverting output high. A high level on DI forces non-inverting output high and inverting output low.
6, 7	GND	Ground
9	Y	Non-inverting Driver Output
10	Z	Inverting Driver Output
11	B	Inverting Receiver Input
12	A	Non-inverting Receiver Input
14	VCC	Positive Supply VCC. Bypass to GND with a 0.1 μ F capacitor.
1, 8, 13	NC	No Connect, not internally connected

Note: On the 14-pin package connect both pins 6 and 7 to Ground.

ABSOLUTE MAXIMUM RATINGS

These are stress ratings only and functional operation of the device at these ratings or any other above those indicated in the operation sections of the specifications below is not implied. Exposure to absolute maximum rating conditions for extended periods of time may affect reliability.

Supply Voltage (V_{CC}).....+ 7.0V
 Input voltage at control input pins (\overline{RE} , DE) -0.3V to $V_{CC}+0.3V$
 Driver input voltage (DI)-0.3V to $V_{CC}+0.3V$
 Driver output voltage (A, B, Y, and Z)+/-13V
 Receiver input voltage (A, B)+/-13V
 Package Power Dissipation:
 Maximum Junction Temperature 150°C
 14-Pin SO $\theta_{JA} = 86^{\circ}C/W$
 Storage Temperature.....-65°C to +150°C
 Lead Temperature (soldering, 10s)..... +300°C

RECOMMENDED OPERATING CONDITIONS

Recommended Operating Conditions		Min.	Nom.	Max.	Unit
Supply Voltage, V_{CC}		4.5	5	5.5	V
Input Voltage on A and B pins		-7		12	V
High-level input voltage (DI, DE or \overline{RE}), V_{IH}		2		V_{CC}	V
Low-level input voltage (DI, DE or \overline{RE}), V_{IL}		0		0.8	V
Output Current	Driver	-60		60	mA
	Receiver	-8		8	
Signaling Rate, 1/t _{UI}				115	kbps
Operating Free Air Temperature, T_A	Industrial Grade (E)	-40		85	°C
	Extended Temp Grade (M)	-40		125	
Junction Temperature, T_J		-40		150	°C

Note: The least positive (most negative) limit is designated as the maximum value.

ELECTRICAL CHARACTERISTICS

Unless otherwise stated, $V_{CC}=5V\pm 10\%$, $T_{AMB}=T_{MIN}$ to T_{MAX} . Typical values at $T_{AMB}=25^{\circ}C$

PARAMETER		TEST CONDITIONS	MIN	TYP	MAX	UNIT
Digital Input Signals: DI, DE, \overline{RE}						
Logic input thresholds		High, V_{IH}	2.0			V
		Low, V_{IL}			0.8	
Logic Input Current		$T_A = 25^{\circ}C$, after first transition, Note 4			± 1	μA
Input Hysteresis		$T_A = 25^{\circ}C$		100		mV
Driver						
Differential Driver Output (V_{OD})		No Load			V_{CC}	V
Differential Driver Output, Test 1		$R_L=100\Omega$ (RS-422), Figure 1	2		V_{CC}	V
		$R_L=54\Omega$ (RS-485), Figure 1	1.5	2.4	V_{CC}	
Differential Driver Output, Test 2		Figure 3a, $V_{CM} = -7$ to $+12V$	1.5		V_{CC}	
Change in Magnitude of Differential Output Voltage (ΔV_{OD}) Note 1		$R_L=54$ or 100Ω , Figure 1			± 0.2	V
Driver Common Mode Output Voltage (V_{CC})		$R_L=54$ or 100Ω , Figure 1	-1		3	V
Change in Common Mode Output Voltage (ΔV_{OC})		$R_L=54$ or 100Ω , Figure 1			± 0.2	V
Driver Short Circuit Current Limit		$-7V \leq V_{OUT} \leq +12V$			± 250	mA
Output Leakage Current (Full-duplex versions, Y & Z pins)		DE=0, $V_{OUT}=12V$			125	μA
		$\overline{RE}=0$, $V_{CC}=0$ or $5.5V$, $V_{OUT}=-7V$	-100			
Receiver						
Receiver Input Resistance		$7V \leq V_{CM} \leq 12V$	96			K Ω
Input Current (A, B pins)		DE=0, $V_{IN}=12V$, $V_{CC}=0$ or $5.5V$			125	μA
		$V_{IN}=-7V$	-100			
Receiver Differential Threshold (V_A-V_B)		$-7V \leq V_{CM} \leq 12V$, Figure 2	-200	-110	-40	mV
Receiver Input Hysteresis				25		mV
Receiver Output Voltage	V_{OH}	$I_{OUT} = -8mA$, $V_{ID} = -40mV$, Figure 2	$V_{CC}-1.5$			V
	V_{OL}	$I_{OUT} = 8mA$, $V_{ID} = -200mV$, Figure 2			0.4	
High-Z Receiver Output Current		$V_{CC} = 5.5V$, $0 \leq V_{OUT} \leq V_{CC}$			± 1	μA
Receiver Output Short Circuit Current		$0.0V \leq V_{RO} \leq V_{CC}$			± 95	mA
Supply and Protection						
Supply Current	IQ, Active Mode	No load, DI=0 or V_{CC}		300	900	μA
	Shutdown Mode, Note 3	DE=0, $\overline{RE}=V_{CC}$, DI= V_{CC}		0.650	1	μA

Notes:

- Change in Magnitude of Differential Output Voltage and Change in Magnitude of Common Mode Output Voltage are the changes in output voltage when DI input changes state.
- The transceivers are put into shutdown by bringing \overline{RE} high and DE low. If the inputs are in this state for less than 50ns the device does not enter shutdown. If the enable inputs are held in this state for at least 600ns the device will be in shutdown. In this low power mode most circuitry is disabled and supply current is typically 650nA.
- Hot-swap circuit adds pull-down resistance to first DE or \overline{RE} transition.

ELECTRICAL CHARACTERISTICS

Unless otherwise stated, $V_{CC}=5V\pm 10\%$, $T_{AMB}=T_{MIN}$ to T_{MAX} . Typical values at $T_{AMB}=25^{\circ}C$

PARAMETER	TEST CONDITIONS	MIN	TYP	MAX	UNIT
Thermal Shutdown Temperature	Junction temperature		165		°C
Thermal Shutdown Hysteresis			15		
ESD Protection for A, B, Y, Z pins	IEC 1000-4-2 Air Discharge		±15		kV
	IEC 1000-4-2 Contact		±8		
	Human Body Model		±15		
ESD Protection for RO, DI, DE, \overline{RE} pins	Human Body Model		±2		

Notes:

1. Change in Magnitude of Differential Output Voltage and Change in Magnitude of Common Mode Output Voltage are the changes in output voltage when DI input changes state.
3. The transceivers are put into shutdown by bringing \overline{RE} high and DE low. If the inputs are in this state for less than 50ns the device does not enter shutdown. If the enable inputs are held in this state for at least 600ns the device will be in shutdown. In this low power mode most circuitry is disabled and supply current is typically 650nA.
4. Hot-swap circuit adds pull-down resistance to first DE or \overline{RE} transition.

TIMING CHARACTERISTICS

Unless otherwise stated, $V_{CC}=5V\pm 10\%$, $T_{AMB}=T_{MIN}$ to T_{MAX} . Typical values at $T_{AMB}=25^{\circ}C$

SP3080E DRIVER CHARACTERISTICS:	Conditions	Min.	Typ.	Max.	Unit
Data Signaling Rate (1 / t _{UI})	Duty Cycle 40 to 60%	115			Kbps
Driver Propagation Delay (t _{PHL} , t _{PLH})	R _L = 54Ω, C _L = 50pF, Figure 3	500	1000	2600	ns
Driver Output Rise/Fall Time (t _R , t _F)		667	800	2500	ns
Driver Differential Skew (t _{PLH} – t _{PHL})			40	±200	ns
Driver Enable to Output High (t _{DZH})	SP3080E Figure 4, 5			3500	ns
Driver Enable to Output Low (t _{DZL})				3500	ns
Driver Disable from Output High (t _{DHZ})				100	ns
Driver Disable from Output Low (t _{DLZ})				100	ns
Shutdown to Driver Output Valid (t _{DZV})	Figure 5			6000	ns

Receiver CHARACTERISTICS:	Conditions	Min.	Typ.	Max.	Unit
Receiver Prop. Delay	C _L = 15pF, V _{ID} = ±2V, Figure 6		90	200	ns
Differential Receiver Skew			6	±30	ns
Receiver Output Rise/Fall Time	C _L = 15pf			15	ns
Receiver Enable to Output High (t _{ZH})	Figure 7, 8		20	50	ns
Receiver Enable to Output Low (t _{ZL})	Figure 7, 8		16	50	ns
Receiver Disable from High (t _{HZ})	Figure 7, 8		20	50	ns
Receiver Disable from Low (t _{LZ})	Figure 7, 8		18	50	ns
Shutdown to Receiver Output Valid (t _{ROV})				3500	ns
Time to Shutdown, Note 3,5		50	200	600	ns

Notes:

1. Change in Magnitude of Differential Output Voltage and Change in Magnitude of Common Mode Output Voltage are the changes in output voltage when DI input changes state.
3. The transceivers are put into shutdown by bringing \overline{RE} high and DE low. If the inputs are in this state for less than 50ns the device does not enter shutdown. If the enable inputs are held in this state for at least 600ns the device will be in shutdown. In this low power mode most circuitry is disabled and supply current is typically 650nA.
4. Hot-swap circuit adds pull-down resistance to first DE or \overline{RE} transition.
5. Characterized, Not 100% tested

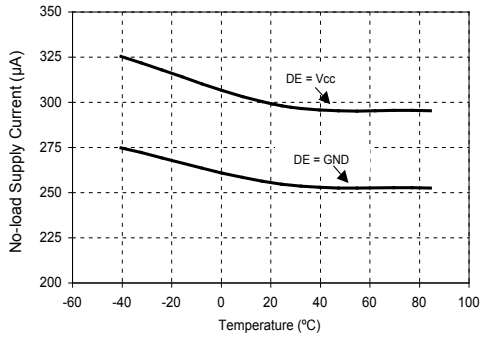

No-load Supply Current vs Temperature

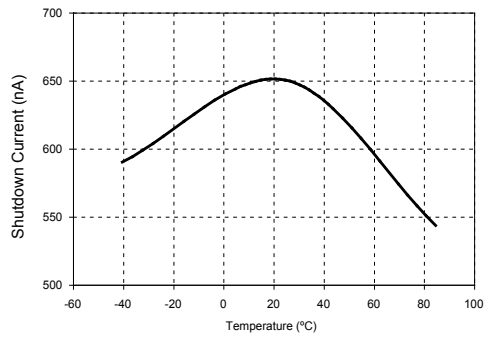

Shutdown Current vs Temperature

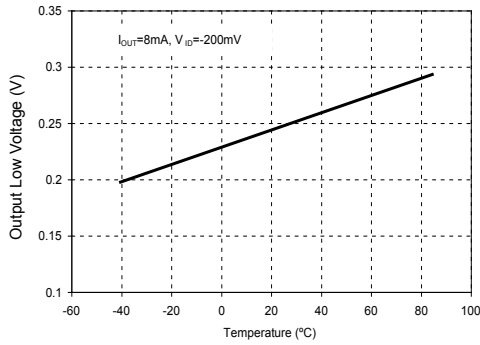

Receiver Output Low Voltage vs Temperature

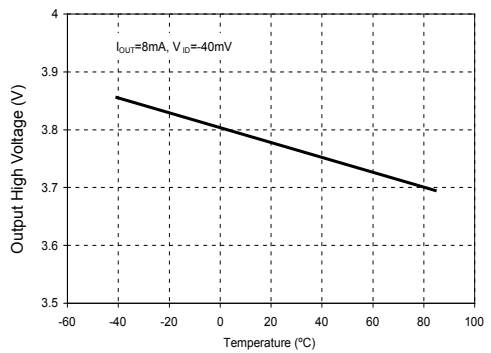

Receiver Output High Voltage vs Temperature

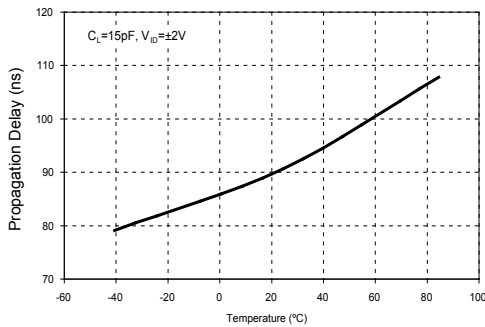

SP3080 Receiver Average Propagation Delay vs Temperature

TYPICAL PERFORMANCE CHARACTERISTICS

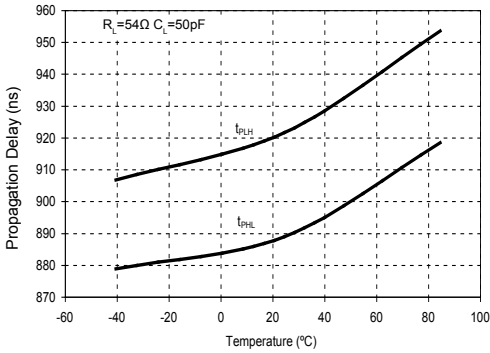

SP3080 Driver Propagation Delay vs Temperature

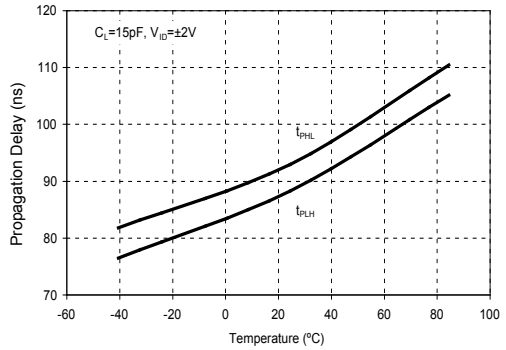

SP3080 Receiver Propagation Delay vs Temperature

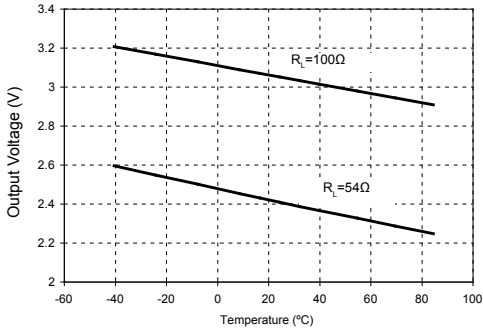

Driver Differential Output Voltage vs Temperature

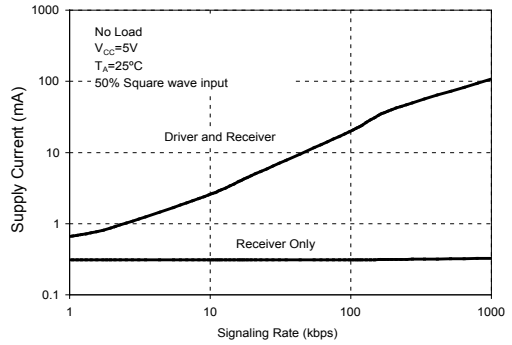

SP3080 Supply Current vs Signaling Rate

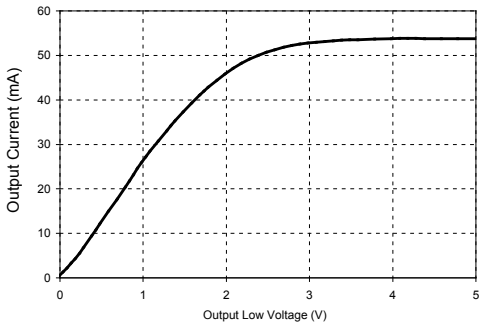

Output Current vs Receiver Low Voltage

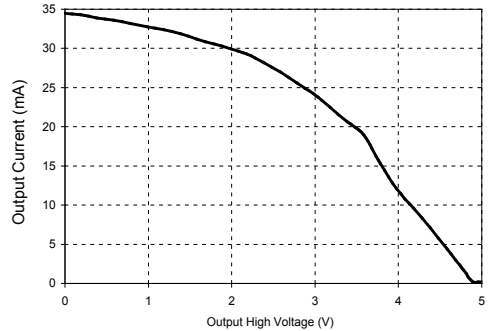

Output Current vs Receiver Output High Voltage

TYPICAL PERFORMANCE CHARACTERISTICS

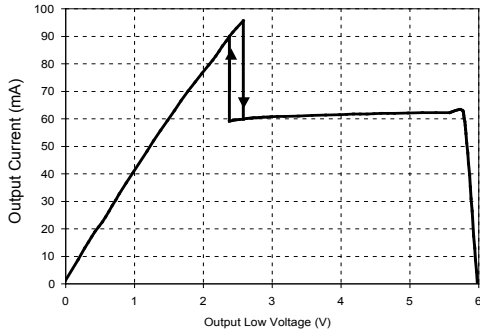

Output Current vs Driver Output Low Voltage

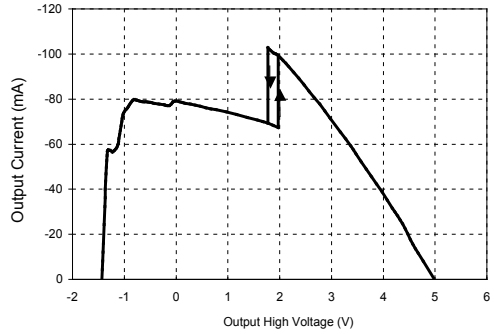

Output Current vs Driver Output High Voltage

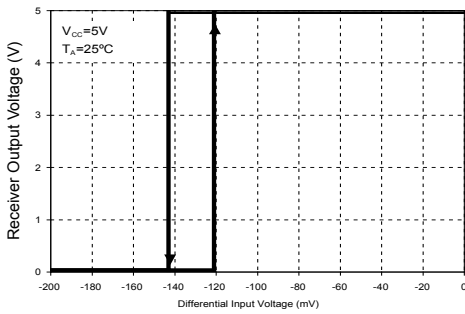

Receiver Output Voltage vs Differential Input Voltage

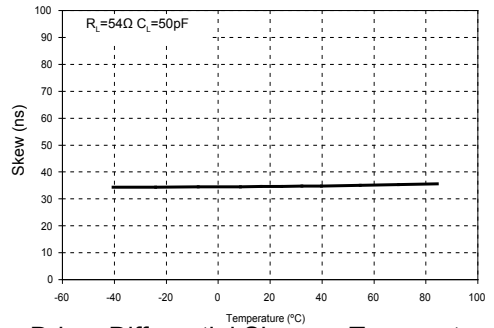

Driver Differential Skew vs Temperature

TYPICAL PERFORMANCE CHARACTERISTICS

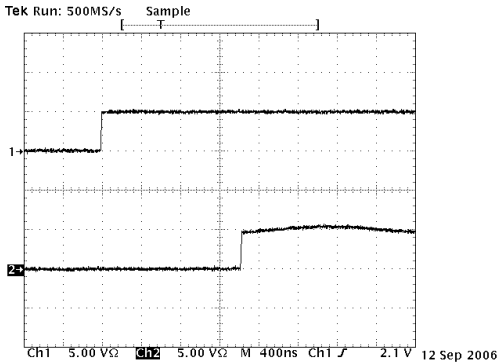

SP3080 Driver and Receiver Waveform, Low to High

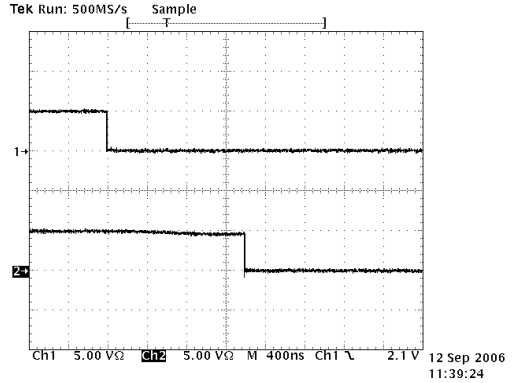

SP3080 Driver and Receiver Waveform, High to Low

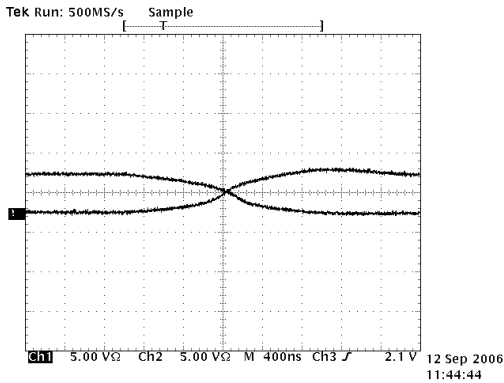

SP3080 Driver output Waveform, Low to High

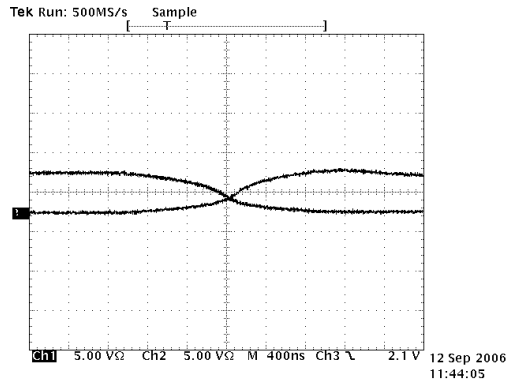

SP3080 Driver output Waveform, High to Low

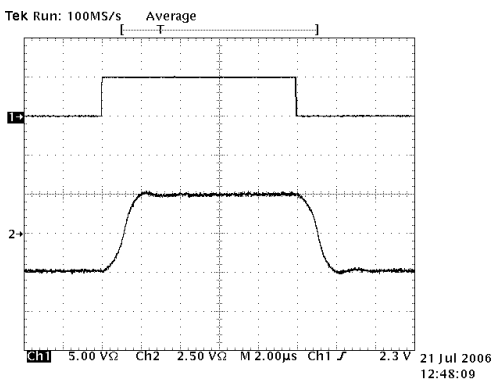

SP3080 Driver Propagation Delay

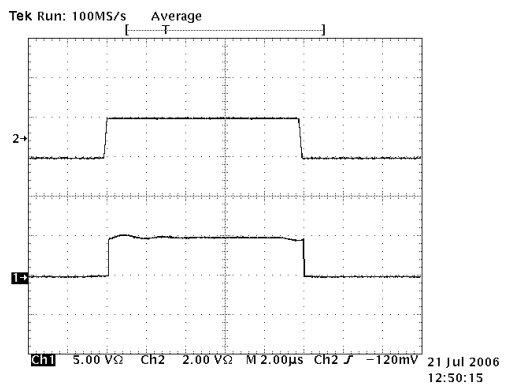

SP3080 Receiver Propagation Delay

TYPICAL PERFORMANCE CHARACTERISTICS

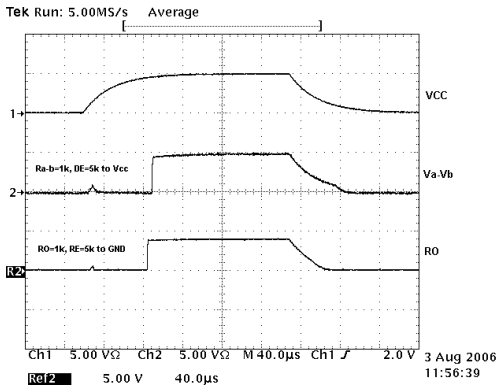

SP3080 Driver and Receiver Hot Swap
Performance vs. Vcc

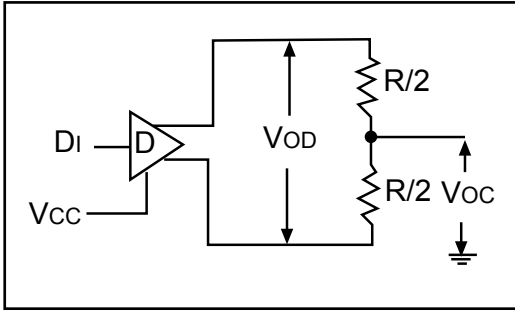

Figure 1. Driver DC Test Circuit

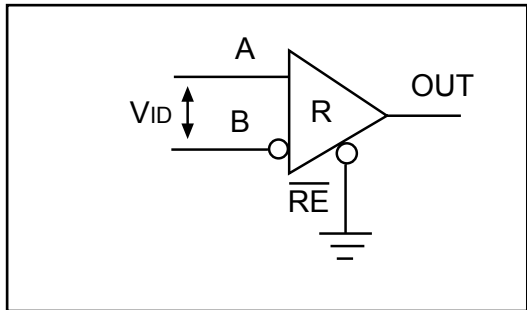

Figure 2. Receiver DC Test Circuit

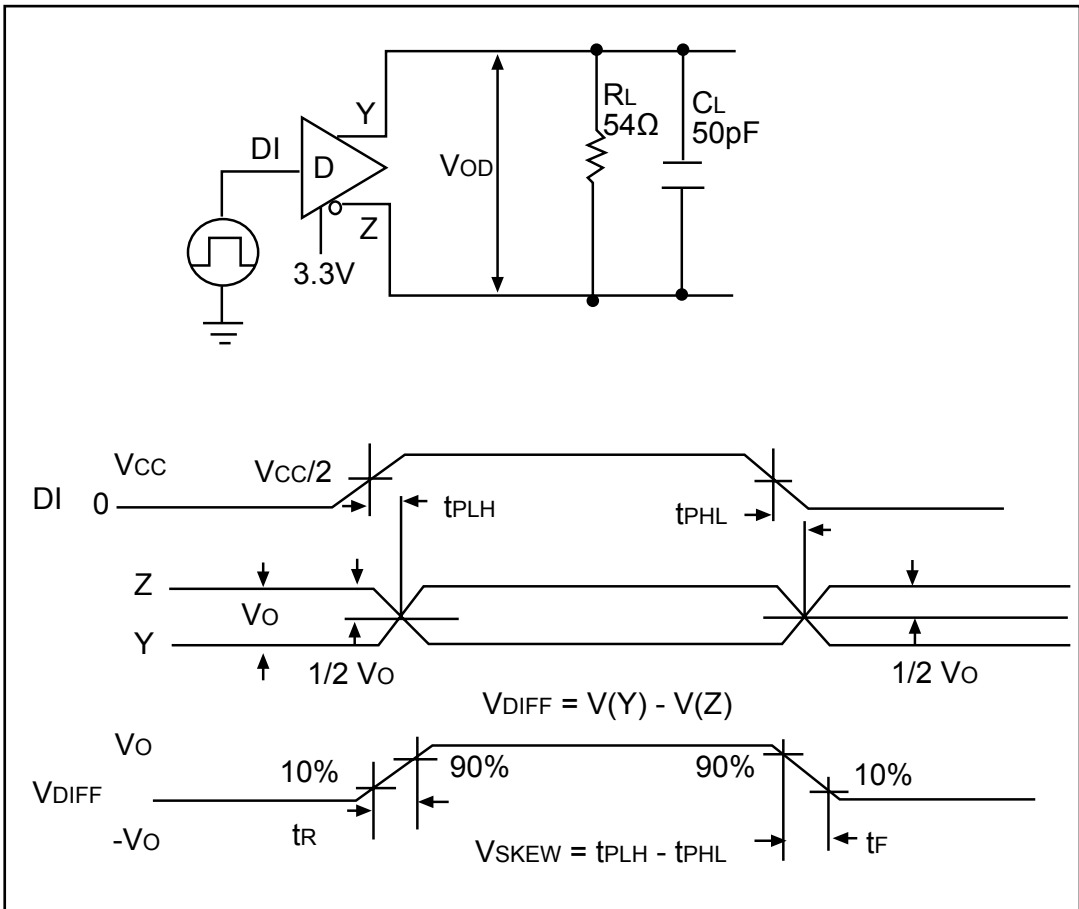

Figure 3. Driver Propagation Delay Time Test Circuit and Timing Diagram

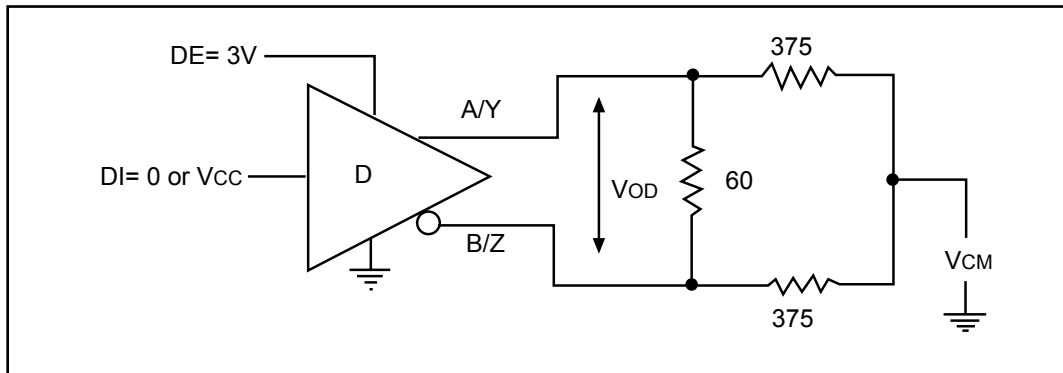

Figure 3a. Driver V_{OD} Test 2
Driver Differential Output Test Circuit

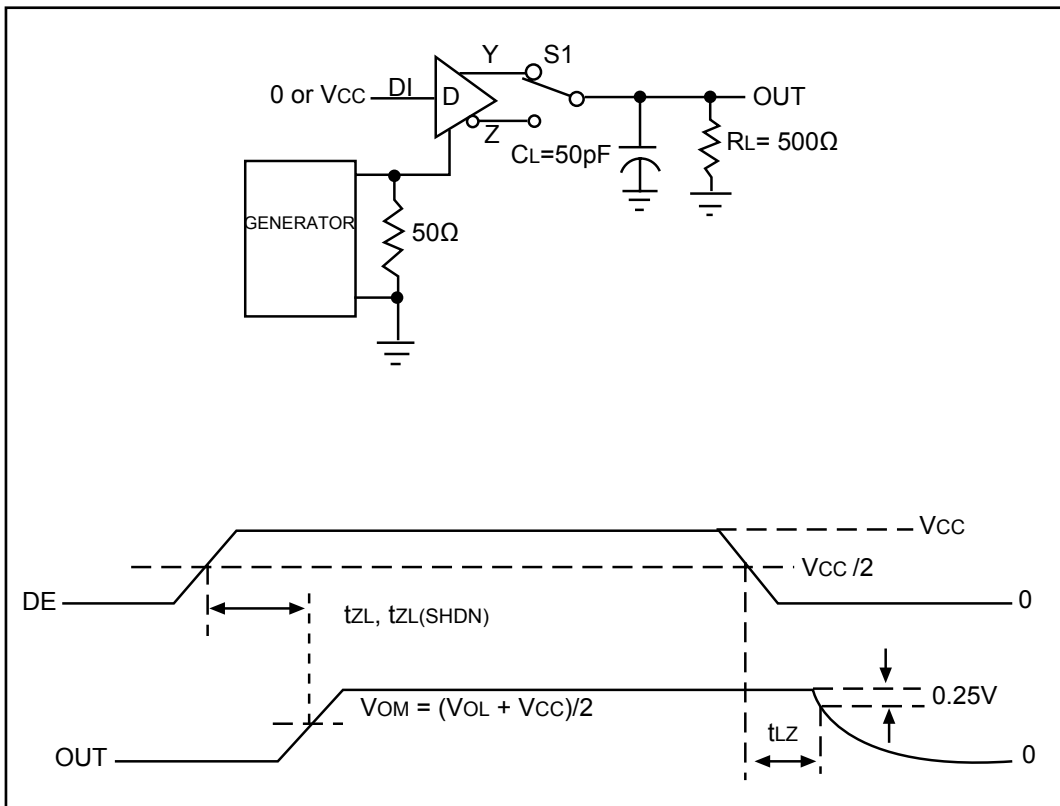

Figure 4. Driver Enable and Disable Times Test Circuit and Timing Diagram

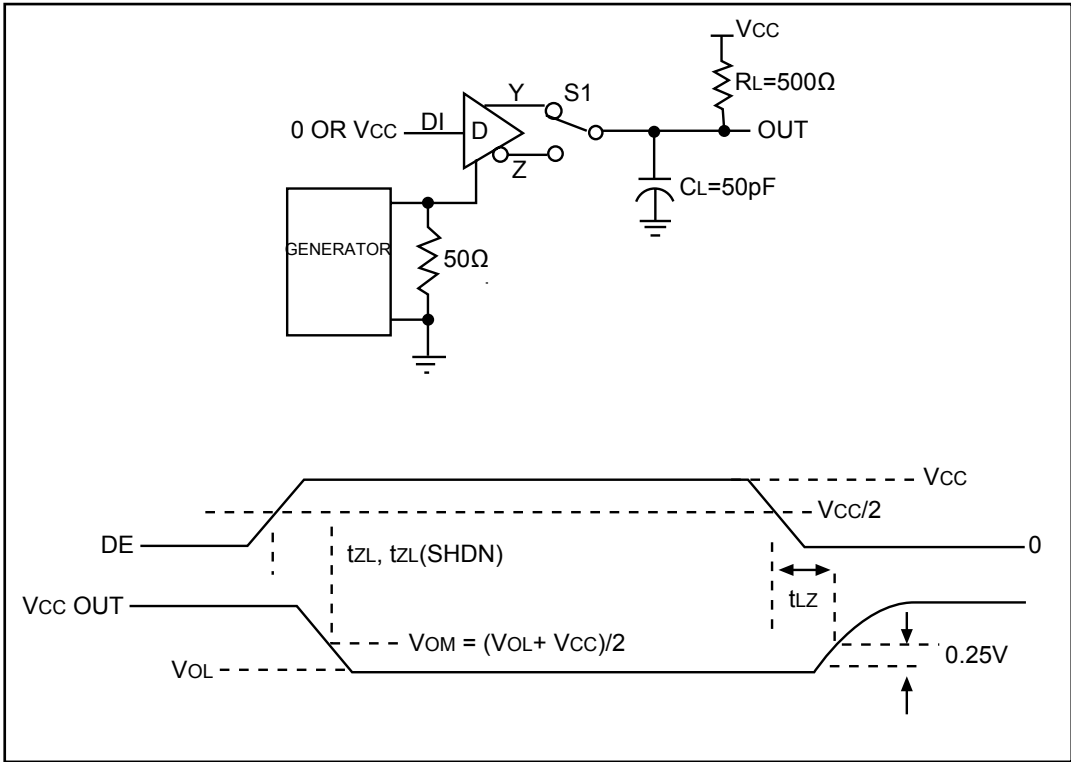

Figure 5. Driver Enable and Disable Times Test Circuit and Timing Diagram

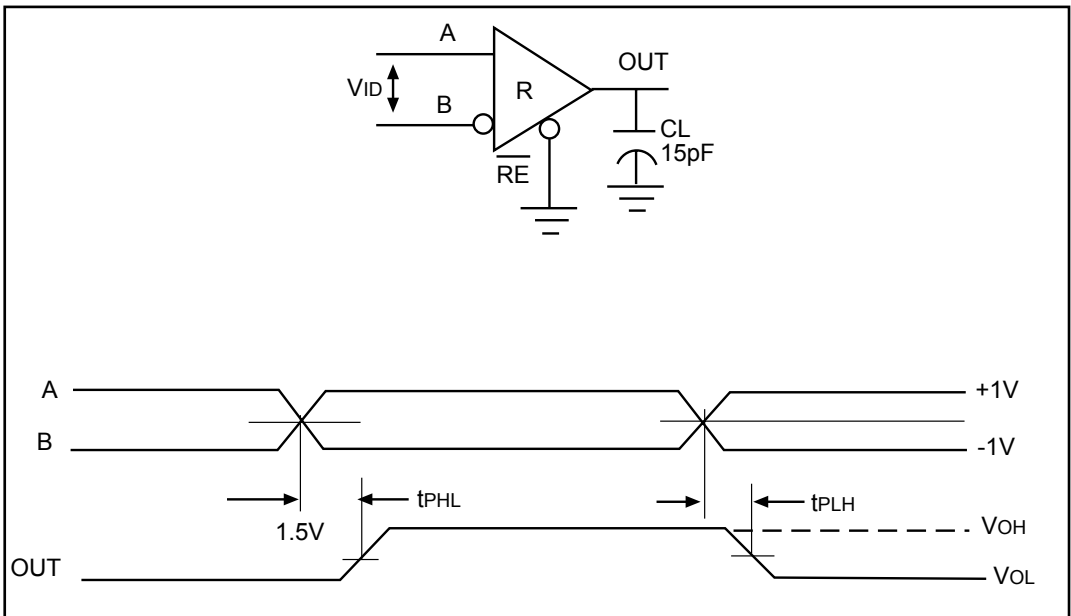

Figure 6. Receiver Propagation Delay Test Circuit and Timing Diagram

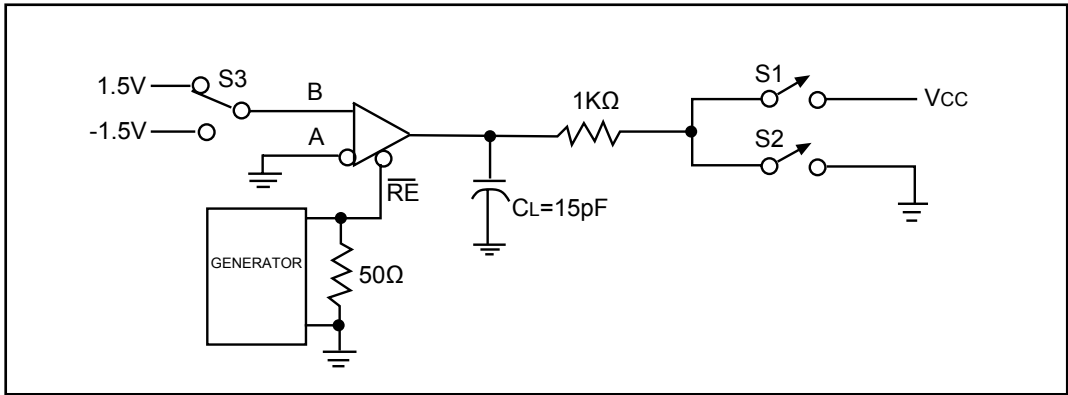

Figure 7. Receiver Enable and Disable Times Test Circuit

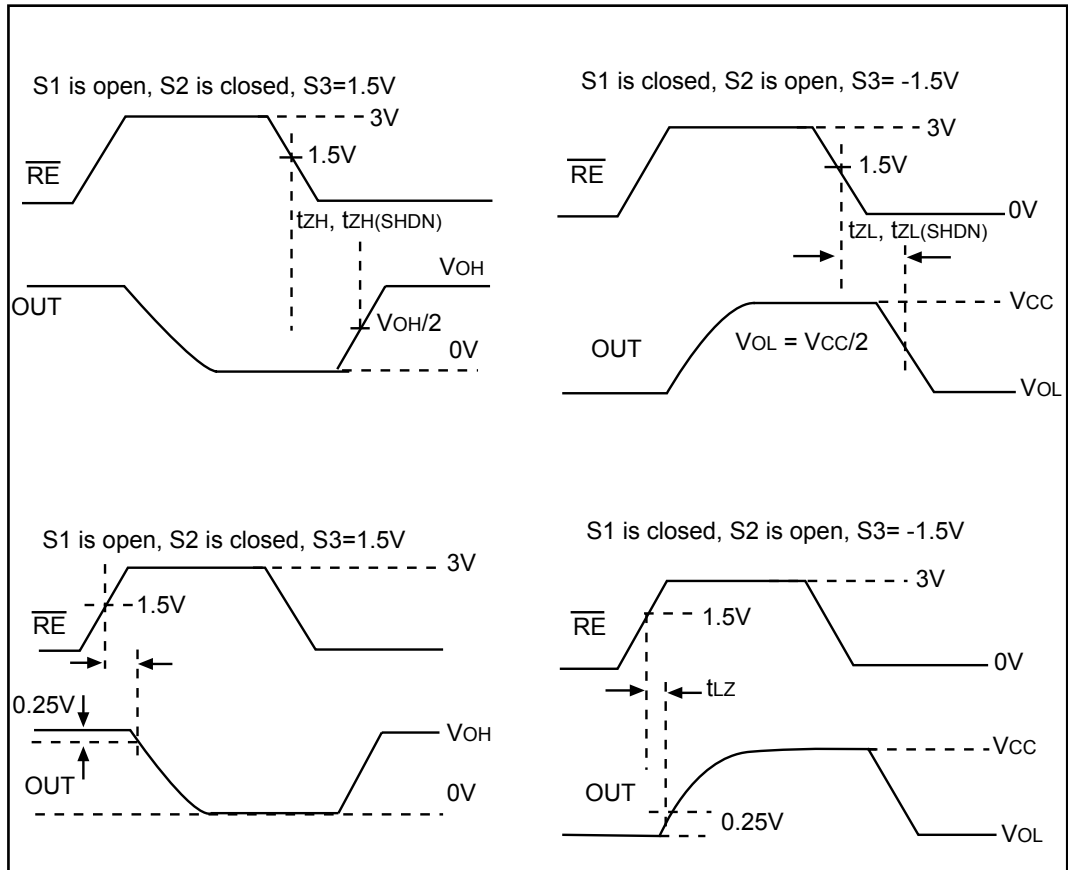

Figure 8. Receiver Enable and Disable Timing Diagram

SP3080E (Full Duplex)

Transmitting				
Inputs			Outputs	
\overline{RE}	DE	DI	Y	Z
X	1	1	1	0
X	1	0	0	1
0	0	X	High-Z	
1	0	X	Shutdown	

Receiving			
Inputs			Output
\overline{RE}	DE	VA- VB	RO
0	X	$\geq -40mV$	1
0	X	$\leq -200mV$	0
0	X	Open/shorted	1
1	1	X	High-Z
1	0	X	Shutdown

Note: Receiver inputs $-200mV < VA - VB < -40mV$, should be considered indeterminate

PRODUCT SELECTOR GUIDE

Part Number	Duplex	Data Rate (Mbps)	Shut-down	Receiver & Driver Enable	Trans on Bus	Foot-print	pin-compatible upgrade from:
SP3080E	Full	0.115	Yes	Yes	256	SN75180	MAX3080

DETAILED DESCRIPTION

SP3080E is an advanced RS-485/RS-422 transceiver. It contains one driver and one receiver. The device features fail-safe circuitry that guarantees a logic-high receiver output when the receiver inputs are open or shorted, or when they are connected to a terminated transmission line with all drivers disabled. SP3080E also features a hot-swap capability allowing live insertion without error data transfer.

The SP3080E features reduced slew-rate drivers that minimize EMI and reduce reflections caused by improperly terminated cables, allowing error-free data transmission up to 115kbps. The SP3080E is a full duplex transceiver.

The device operates from a single 5.0V supply. Driver output short-circuit current is limited. Thermal-shutdown circuitry protects driver against excessive power dissipation. When activated, the thermal-shutdown circuitry places the driver outputs into a high-impedance state.

RECEIVER INPUT FILTERING

SP3080E receiver incorporates input filtering in addition to input hysteresis. This filtering enhances noise immunity with differential signals that have very slow rise and fall times. Receiver propagation delay increases due to this filtering.

ADVANCED FAIL SAFE

Ordinary RS485 differential receivers will be in an indeterminate state whenever A - B is less than $\pm 200\text{mV}$. This situation can occur whenever the data bus is not being actively driven. The Advanced Failsafe feature of the SP3080E guarantees a logic-high receiver output if the receiver's differential inputs are shorted, open-circuit, or if they are shunted by a termination resistor.

The receiver thresholds of the SP3080E is very precise and offset by at least a 40mV noise margin from ground. This results in a logic-high receiver output at zero volts input differential while maintaining compliance with the EIA/TIA-485 standard of $\pm 200\text{mV}$.

HOT-SWAP CAPABILITY

When a micro-processor or other logic device undergoes its power-up sequence its logic-outputs are typically at high impedance. In this

state they are unable to drive the DE and $\overline{\text{RE}}$ signals to a defined logic level. During this period, noise, parasitic coupling or leakage from other devices could cause standard CMOS enable inputs to drift to an incorrect logic level.

If circuit boards are inserted into an energized backplane (commonly called "live insertion" or "hot-swap") power may be suddenly applied to all circuits. Without the hot-swap capability, this situation could improperly enable the transceiver's driver or receiver, driving invalid data onto shared busses and possibly causing driver contention or device damage.

The SP3080E contains a special power-on-reset circuit that holds DE low and $\overline{\text{RE}}$ high for approximately 10 microseconds. After this initial power-up sequence the hot-swap circuit becomes transparent, allowing for normal, unskewed enable and disable timings.

 $\pm 15\text{KV}$ ESD PROTECTION

ESD-protection structures are incorporated on all pins to protect against electrostatic discharges encountered during handling and assembly. The driver output and receiver inputs of the SP3080E have extra protection against static electricity. Sipex uses state of the art structures to protect these pins against ESD of $\pm 15\text{kV}$ without damage. The ESD structures withstand high ESD in all states: normal operation, shutdown, and powered down. After an ESD event, the SP3080E keeps working without latch-up or damage.

ESD protection can be tested in various ways. The transmitter outputs and receiver inputs of the SP3080E is characterized for protection to the following limits:

- $\pm 15\text{kV}$ using the Human Body Model
- $\pm 8\text{kV}$ using the Contact Discharge method specified in IEC 1000-4-2
- $\pm 15\text{kV}$ Air-gap

ESD TEST CONDITIONS

ESD performance depends on a variety of conditions. Contact Sipex for a reliability report that documents test setup, methodology and results.

IEC 1000-4-2

The IEC 1000-4-2 standard covers ESD testing and performance of finished equipment. However, it does not specifically refer to integrated circuits. The SP3080E helps you design equipment to meet IEC 1000-4-2, without sacrificing board space and cost for external ESD-protection components.

The major difference between tests done using the Human Body Model and IEC 1000-4-2 is a higher peak current in IEC 1000-4-2 series resistance is lower in the IEC 1000-4-2 model. Hence, the ESD withstand voltage measured to IEC 1000-4-2 is generally lower than that measured using the human body model.

The air-gap test involves approaching the device with a charged probe. The contact discharge method connects the probe to the device before the probe is energized.

MACHINE MODEL

The machine model for ESD tests all pins using a 200pF storage capacitor and zero discharge resistance. The objective is to emulate the stress caused when I/O pins are contacted by handling equipment during test and assembly.

256 TRANSCEIVERS ON THE BUS

The standard RS-485 receiver input impedance is 12k Ω (1 unit load). A standard driver can drive up to 32 unit loads. The SP3080E family of transceivers has only a 1/8th unit load receiver input impedance (96k Ω), thereby allowing eight times as many, up to 256, transceivers to be connected in parallel on a communication line. Any combination of these devices and other RS-485 transceivers up to a total of 32 unit loads may be connected to the line.

LOW POWER SHUTDOWN MODE

Low-power shutdown mode is initiated by bringing both \overline{RE} high and DE low simultaneously. While in shutdown devices typically draw only 200nA of supply current. DE and \overline{RE} may be tied together and driven by a single control signal. Devices are guaranteed not to enter shutdown if \overline{RE} is high and DE is low for less than

50ns. If the inputs are in this state for at least 600ns, the parts are shutdown.

Enable times t_{ZH} and t_{ZL} apply when the part is not in low-power shutdown state. Enable times $t_{ZH}(SHDN)$ and $t_{ZL}(SHDN)$ apply when the parts are shut down. The drivers and receivers take longer to become enabled from low power shutdown mode $t_{ZL}(SHDN)$ and $t_{ZL}(SHDN)$ than from driver/receiver-disable mode (t_{ZH} , t_{ZL}).

DRIVER OUTPUT PROTECTION

Two mechanisms prevent excessive output current and power dissipation caused by faults or by bus contention. First, a driver-current limit on the output stage provides immediate protection against short circuits over the whole common-mode voltage range. Second, a thermal-shutdown circuit forces the driver outputs into a high-impedance state if junction temperature becomes excessive.

LINE LENGTH, EMI, AND REFLECTIONS

SP3080E feature controlled slew-rate drivers that minimize EMI and reduce reflections caused by improperly terminated cables.

SP3080E driver rise and fall times are limited to no faster than 667ns, allowing error-free data transmission up to 115kbps.

The RS-485/RS-422 standard covers line lengths up to 4,000ft. Maximum achievable line length is a function of signal attenuation and noise. Use of slew-controlled drivers such as the SP3080E may help to reduce crosstalk interference and permit communication over longer transmission lines.

Termination prevents reflections by eliminating the impedance mismatches on a transmission line. Line termination is typically used if rise and fall times are shorter than the round-trip signal propagation time. Slew-limited drivers may reduce or eliminate the need for cable termination in many applications.

TYPICAL APPLICATIONS:

Bi-Directional Full-Duplex Network

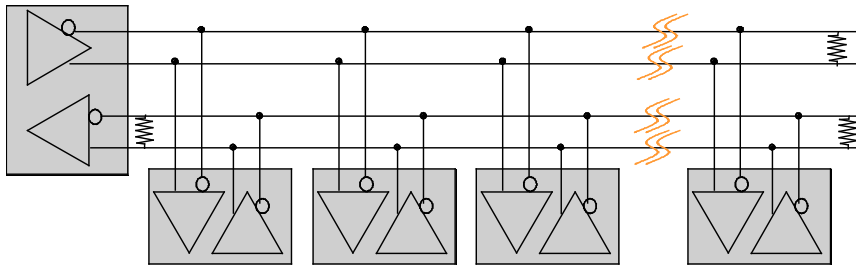

Point to Multi-Point Repeater

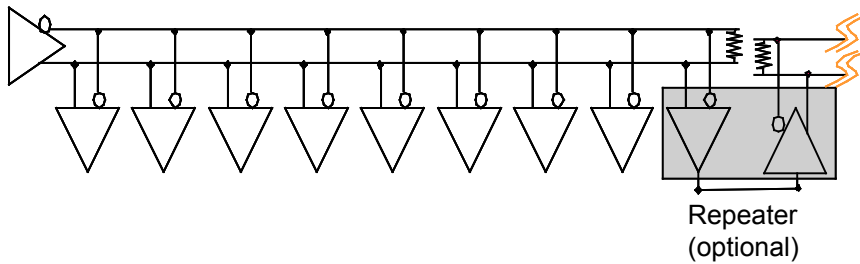

REVISION HISTORY			
REV.	DESCRIPTION	DATE	APP'D
A	DRAWING ORIGINATION	04/17/06	JL

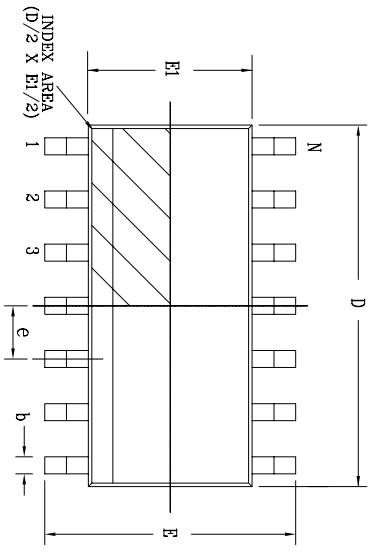

Top View

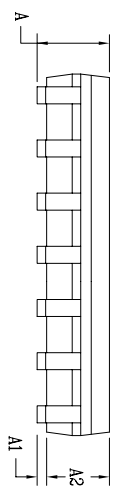

Side View

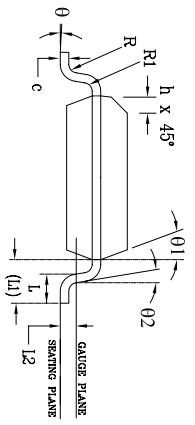

Front View

14 Pin SOICN		JEDEC MS-012		Variation AB		
SYMBOLS		DIMENSIONS IN MM (Control Unit)		DIMENSIONS IN INCH (Reference Unit)		
	MIN	NOM	MAX	MIN	NOM	MAX
A	1.35	—	1.75	0.053	—	0.069
A1	0.10	—	0.25	0.004	—	0.010
A2	1.25	—	1.65	0.049	—	0.065
b	0.31	—	0.51	0.012	—	0.020
c	0.17	—	0.25	0.007	—	0.010
E	—	6.00 BSC	—	—	0.236 BSC	—
E1	—	3.90 BSC	—	—	0.154 BSC	—
e	—	1.27 BSC	—	—	0.050 BSC	—
h	0.25	—	0.50	0.010	—	0.020
L	0.40	—	1.27	0.016	—	0.050
L1	—	1.04 REF	—	—	0.041 REF	—
L2	—	0.25 BSC	—	—	0.010 BSC	—
R	0.07	—	—	0.003	—	—
R1	0.07	—	—	0.003	—	—
θ	0°	—	8°	0°	—	8°
θ1	5°	—	15°	5°	—	15°
θ2	0°	—	—	0°	—	—
D	—	8.65 BSC	—	—	0.341 BSC	—
N	—	14	—	—	14	—

SIPEX CORPORATION

14 PIN SOICN PACKAGE OUTLINE

Packaging Approval: 14-PIN SOICN

By: JL Date: 04/17/06 Revision: A Sheet: 1 OF 1

ORDERING INFORMATION

Part number	LEAD FREE	Tape & Reel	Temperature range	Package Type
SP3080EEN	-L	/TR	From -40 to +85°C	14 pin NSOIC
SP3080EMN	-L	/TR	From -40 to +125°C	14 pin NSOIC

All packages are available as lead free (RoHS compliant). To order add “-L” suffix to part number. For Tape and Reel add “/TR”. Reel quantity is 2,500 for NSOIC.

Example: SP3080EEN-L/TR = lead free and Tape and Reel. SP3080EEN/TR = standard with Tape and Reel.



Sipex Corporation

**Headquarters and
Sales Office**
233 South Hillview Drive
Milpitas, CA 95035
TEL: (408) 934-7500
FAX: (408) 935-7600

Sipex Corporation reserves the right to make changes to any products described herein. Sipex does not assume any liability arising out of the application or use of any product or circuit described herein; neither does it convey any license under its patent rights nor the rights of others.