

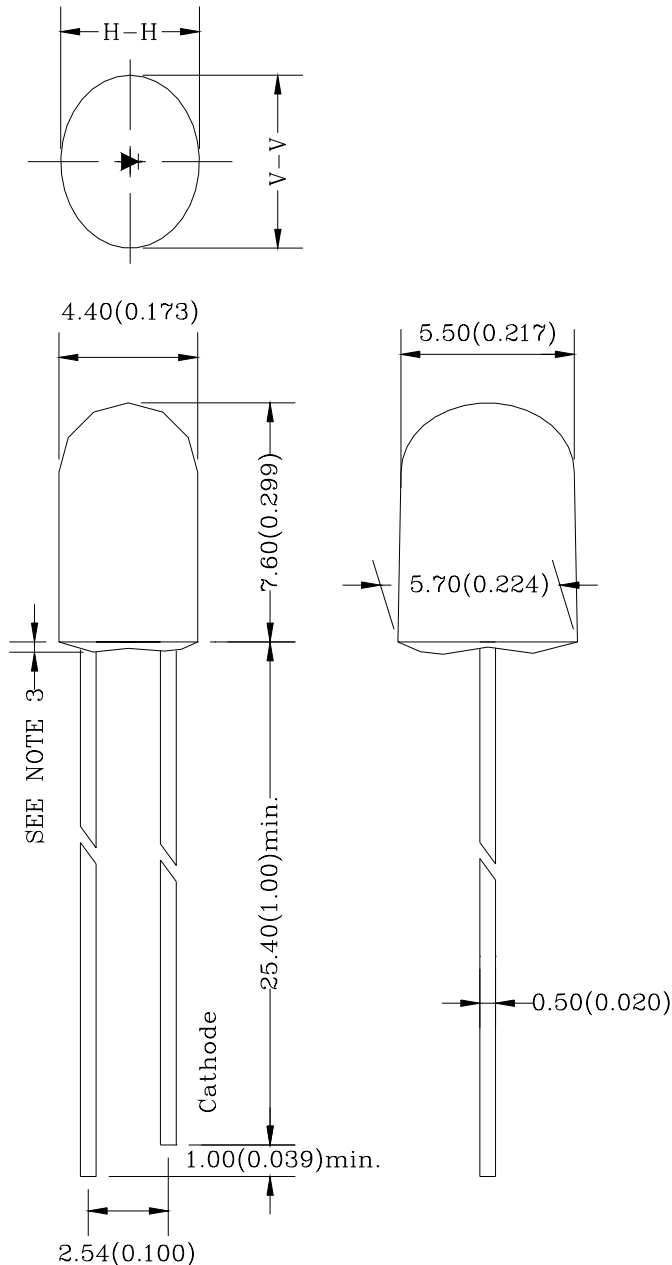

5.5*4.4 mm DIA ELLIPSE LED LAMP

L-763HURC

PACKAGE DIMENSIONS



Note:

1. All Dimensions are in millimeters.
2. Tolerance is $\pm 0.25\text{mm}(0.010\text{ ''})$ Unless otherwise specified.
3. Protruded resin under flange is $1.5\text{mm}(0.059\text{ ''})$ max.
4. Lead spacing is measured where the leads emerge from the package.
5. Specification are subject to change without notice



5.5*4.4 mm DIA ELLIPSE LED LAMP

L-763HURC

FEATURES

- * 5.5*4.0mm DIA ELLIPSE LED LAMP
- * HIGH LUMINOUS INTENSITY OUTPUT.
- * LOW POWER CONSUMPTION.
- * HIGH EFFICIENCY.
- * VERSATILE MOUNTING ON P.C. BOARD OR PANEL.
- * I.C. COMPATIBLE.

CHIP METATERIALS

- * Dice Material : AlGaInP/GaAs
- * Light Color : ULTRA RED
- * Lens Color : WATER CLEAR

ABSOLUTE MAXIMUM RATING : (Ta = 25°C)

SYMBOL	PARAMETER	HI.EFF. RED	UNIT
PAD	Power Dissipation Per Chip	80	mW
VR	Reverse Voltage Per Chip	5	V
IAF	Continuous Forward Current Per Chip	30	mA
IPF	Peak Forward Current Per Chip (Duty – 0.1,1KHz)	60	mA
—	Derating Linear From 25°C Per Chip	0.40	mA/°C
Topr	Operating Temperature Range	-25°C to 85°C	
Tstg	Storage Temperature Range	-40°C to 85°C	

Lead Soldering Temperature { 1.6mm(0.063 inch) From Body } 260°C ± 5°C for 5 Seconds

ELECTRO-OPTICAL CHARACTERISTICS : (Ta = 25°C)

SYMBOL	PARAMETER	TEST CONDITION	MIN.	TYP.	MAX.	UNIT
VF	Forward Voltage	IF = 20mA		2.0	2.6	V
IR	Reverse Current	VR = 5V			100	μA
λD	Dominant Wavelength	IF = 20mA		635		nm
Δλ	Spectral Line Half-Width	IF = 20mA		20		nm
2θ1/2	Half Intensity Angle(H/V)	IF = 20mA		20/55		deg
IV	Luminous Intensity	IF = 20mA		3000		mcd

DRAWING NO. :

DATE :

Page : 2



5.5*4.4 mm DIA ELLIPSE LED LAMP

L-763HURC

