



# Integrated Pressure Sensor, On-Chip Signal Conditioned, Temperature Compensated & Calibrated

The Motorola MPXS4100A series Barometric Absolute Pressure (BAP) sensor for engine control is designed to sense absolute air pressure.

Motorola's BAP sensor integrates on-chip, bipolar op amp circuitry and thin film resistor networks to provide a high output signal and temperature compensation. The small form factor and high reliability of on-chip integration make the Motorola BAP sensor a logical and economical choice for the automotive system designer.

### Features

- 1.8% Maximum Error Over 0° to 85°C
- Surface Mount Package
- Available Tape and Reeled or in Sleeves
- Ideally Suited for Direct Microprocessor Interfacing
- Patented Silicon Shear Stress Strain Gauge
- Temperature Compensated Over -40 to +125°C
- Ideal for Non-automotive applications
- Also Available in Unibody Package (see MPX4100A/D data sheet)

### Application

- Barometric Absolute Pressure for Engine Control

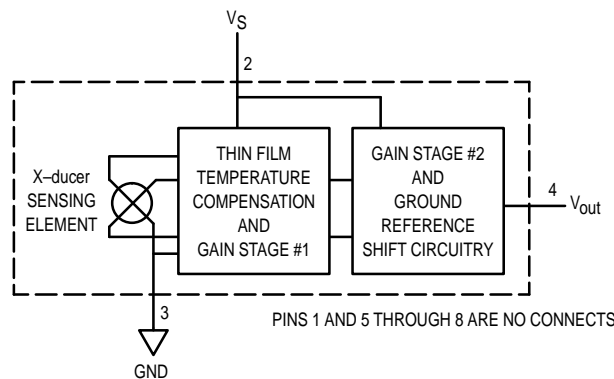

Figure 1. Fully Integrated Pressure Sensor Schematic

### MAXIMUM RATINGS(1)

Rating	Symbol	Value	Unit
Overpressure(2)	$P_{max}$	400	kPa
Burst Pressure(2)	$P_{burst}$	1000	kPa
Storage Temperature	$T_{stg}$	-40 to +125	°C
Operating Temperature	$T_A$	-40 to +125	°C

1.  $T_C = 25^\circ\text{C}$  unless otherwise noted.

2. Exposure beyond the specified limits may cause permanent damage or degradation to the device.

Senseon and X-ducer are trademarks of Motorola, Inc.

REV 1

**MPXS4100A  
SERIES**

**INTEGRATED  
PRESSURE SENSOR  
20 to 105 kPa (2.9 to 15.2 psi)  
0.3 to 4.9 V OUTPUT**

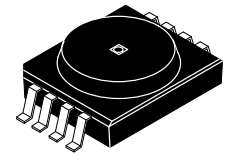

**BASIC CHIP CARRIER  
ELEMENT  
CASE 471-01, STYLE 1**

### PIN NUMBER

1	N/C	5	N/C
2	$V_S$	6	N/C
3	Gnd	7	N/C
4	$V_{out}$	8	N/C

NOTE: Pins 1, 5, 6, 7 and 8 are internal device connections. Do not connect to external circuitry or ground.

## MPXS4100A SERIES

### OPERATING CHARACTERISTICS ( $V_S = 5.1$ Vdc, $T_A = 25^\circ\text{C}$ unless otherwise noted)

Characteristic	Symbol	Min	Typ	Max	Unit
Pressure Range	$P_{OP}$	20	—	105	kPa
Supply Voltage <sup>(1)</sup>	$V_S$	4.85	5.1	5.35	Vdc
Supply Current	$I_o$	—	7.0	10	mAdc
Minimum Pressure Offset <sup>(2)</sup>	$V_{off}$	0.225	0.306	0.388	Vdc
Full Scale Output <sup>(3)</sup>	$V_{FSO}$	4.816	4.897	4.978	Vdc
Full Scale Span <sup>(4)</sup>	$V_{FSS}$	—	4.591	—	Vdc
Accuracy <sup>(5)</sup>	—	—	—	$\pm 1.8$	% $V_{FSS}$
Sensitivity	$\Delta V/\Delta P$	—	54	—	mV/kPa
Response Time <sup>(6)</sup>	$t_R$	—	1.0	—	ms
Output Source Current at Full Scale Output	$I_{o+}$	—	0.1	—	mAdc
Warm-up Time <sup>(7)</sup>	—	—	20	—	ms
Offset Stability <sup>(8)</sup>	—	—	$\pm 0.65$	—	% $V_{FSS}$

### MECHANICAL CHARACTERISTICS

Characteristic	Symbol	Min	Typ	Max	Unit
Weight, Basic Element (Case 432)	—	—	1.5	—	Grams

#### NOTES:

- Device is ratiometric within this specified excitation range.
- Offset ( $V_{off}$ ) is defined as the output voltage at the minimum rated pressure.
- Full Scale Output ( $V_{FSO}$ ) is defined as the output voltage at the maximum or full rated pressure.
- Full Scale Span ( $V_{FSS}$ ) is defined as the algebraic difference between the output voltage at full rated pressure and the output voltage at the minimum rated pressure.
- Accuracy is the deviation in actual output from nominal output over the entire pressure range and temperature range as a percent of span at  $25^\circ\text{C}$  due to all sources of error including the following:
  - Linearity: Output deviation from a straight line relationship with pressure over the specified pressure range.
  - Temperature Hysteresis: Output deviation at any temperature within the operating temperature range, after the temperature is cycled to and from the minimum or maximum operating temperature points, with minimum specified pressure applied.
  - Pressure Hysteresis: Output deviation at any pressure within the specified range, when this pressure is cycled to and from minimum or maximum rated pressure at  $25^\circ\text{C}$ .
  - TcSpan: Span deviation per  $^\circ\text{C}$  over the temperature range of  $0^\circ$  to  $85^\circ\text{C}$ , as a percent of span at  $25^\circ\text{C}$ .
  - TcOffset: Output deviation per  $^\circ\text{C}$  with minimum pressure applied, over the temperature range of  $0^\circ$  to  $85^\circ\text{C}$ .
- Response Time is defined as the time for the incremental change in the output to go from 10% to 90% of its final value when subjected to a specified step change in pressure.
- Warm-up Time is defined as the time required for the product to meet the specified output voltage.
- Offset Stability is the product's output deviation when subjected to 1000 hours of Pulsed Pressure, Temperature Cycling with Bias Test.
- Decoupling circuit shown in Figure 2 required to meet specification.

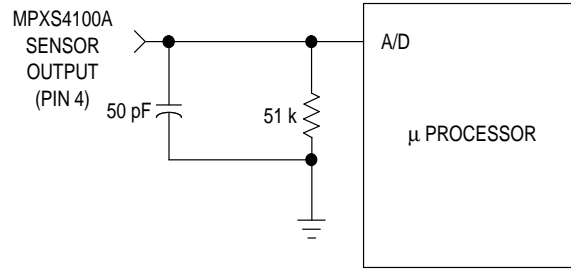

**Figure 2. Recommended Decoupling Filter for Sensor to Microprocessor Interface**

The MPXS4100A series piezoresistive transducer is a state-of-the-art, monolithic, signal conditioned, silicon pressure sensor. This sensor, with its patented X-ducer, combines advanced micromachining techniques, thin film metallization and bipolar semiconductor processing to provide an accurate, high level analog output signal that is proportional to applied pressure. A vacuum is sealed behind the sensor diaphragm providing a reliable pressure reference.

This surface mount package (Case 471) is an absolute sensing configuration package. A fluorosilicone gel isolates the die surface and wire bonds from the environment, while allowing the pressure signal to be transmitted to the silicon

diaphragm. The MPXS4100A series pressure sensor operating characteristics, internal reliability and qualification tests are based on use of dry air as the pressure media. Media other than dry air may have adverse effects on sensor performance and long-term reliability. Contact the factory for information regarding media compatibility in your application.

Figure 2 shows the recommended decoupling circuit for interfacing the output of the integrated BAP sensor to the A/D input of a microprocessor (see Note 9).

Figure 3 shows the sensor output signal relative to pressure input. Typical minimum and maximum output curves are shown for operation over 0 to 85°C temperature range. (Output will saturate outside of the rated pressure range.)

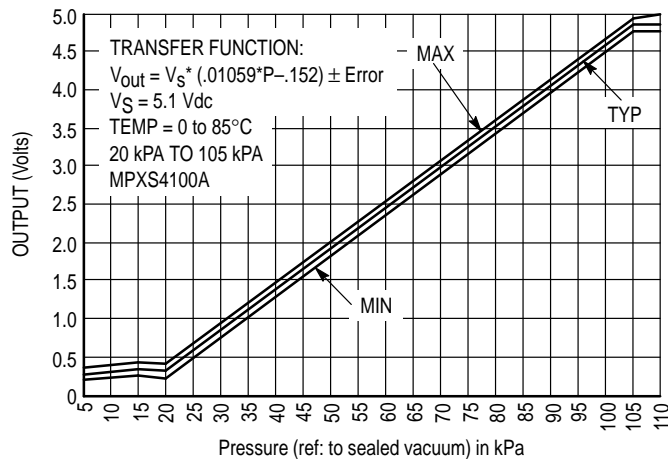

**Figure 3. Output versus Absolute Pressure**

## MPXS4100A SERIES

### Transfer Function (MPXS4100A)

**Nominal Transfer Value:**  $V_{out} = V_S (P \times 0.01059 - 0.1518)$   
 $\pm (\text{Pressure Error} \times \text{Temp. Factor} \times 0.01059 \times V_S)$   
 $V_S = 5.1 \text{ V} \pm 0.25 \text{ Vdc}$

### Temperature Error Band

#### MPXS4100A Series

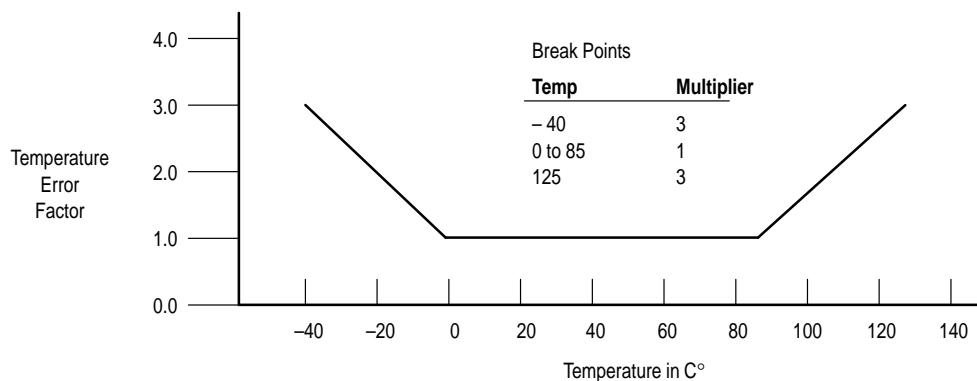

NOTE: The Temperature Multiplier is a linear response from 0°C to -40°C and from 85°C to 125°C

### Pressure Error Band

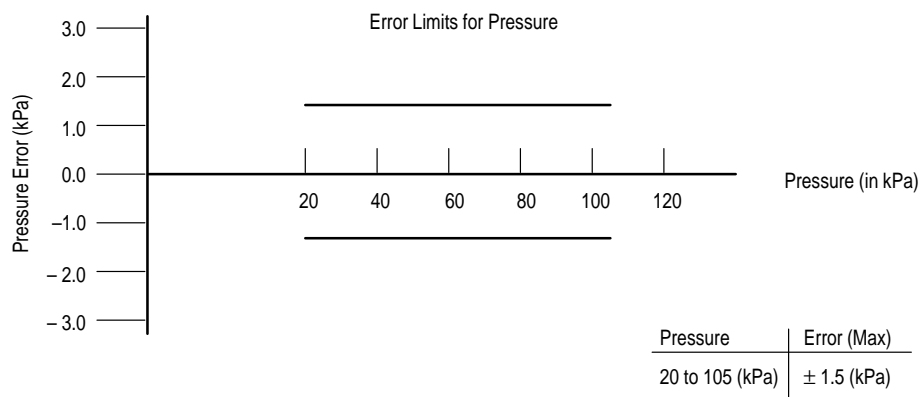

## ORDERING INFORMATION

The MPXS4100A series BAP silicon pressure sensors are available shipped in sleeves or tape and reeled.

Device Type Options	Case No.	MPX Series Order No.	Marking
Sleeve Pack	471-01	MPXS4100A6U	MPXS4100A
Tape and Reel	471-01	MPXS4100A6T1	MPXS4100A

Device	Reel Size	Tape Width	Quantity
MPXS4100A6T1	13" dia.	44 mm	250

## INFORMATION FOR USING THE SURFACE MOUNT PACKAGE

### MINIMUM RECOMMENDED FOOTPRINT FOR SURFACE MOUNTED APPLICATIONS

Surface mount board layout is a critical portion of the total design. The footprint for the semiconductor packages must be the correct size to ensure proper solder connection inter-

face between the board and the package. With the correct pad geometry, the packages will self align when subjected to a solder reflow process.

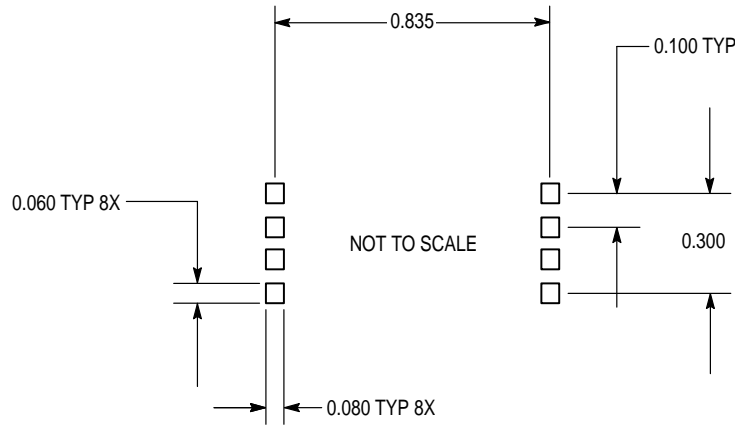

### SOLDERING PRECAUTIONS

The melting temperature of solder is higher than the rated temperature of this device. When the entire device is heated to a high temperature, failure to complete soldering within a short time could result in device damage and/or failure. Therefore, the following items should always be observed in order to minimize the thermal stress to which the devices are subjected.

- Always preheat the device.
- The delta temperature between the preheat and soldering zones should be 100°C or less.\*
- When preheating and soldering, the temperature of the leads and the case, including the port, must not exceed the maximum temperature ratings as shown on the data sheet. When using infrared heating with the reflow soldering method, the difference between the leads and the case shall be a maximum of 10°C.
- Wave soldering is not recommended for the pressure sensor surface mount package due to the exposure of the die to the environment.

- The soldering temperature and time shall not exceed 240°C for more than 5 seconds.
- When shifting from preheating to soldering zones, the maximum temperature gradient or rise rate shall be 2°C/second or less.
- After soldering has been completed, the device should be allowed to cool naturally for at least three minutes. Gradual cooling should be used since the use of forced cooling will increase the temperature gradient and result in latent failure due to mechanical stress.
- Mechanical stress or shock should not be applied during cooling.
- Recommend usage of a no-clean solder paste to avoid circuit board cleaning.

\* Soldering a device without preheating can cause excessive thermal shock and stress which can result in damage to the device.

**MPXS4100A SERIES**

**PACKAGE DIMENSIONS**

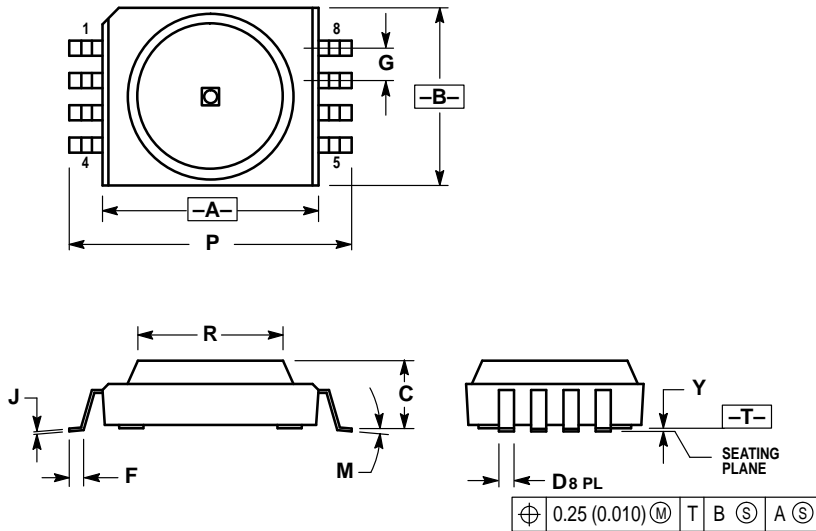

- NOTES:
1. DIMENSIONING AND TOLERANCING PER ANSI Y14.5M, 1982.
  2. CONTROLLING DIMENSION: INCH.
  3. DIMENSIONS A AND B DO NOT INCLUDE MOLD PROTRUSION.
  4. MAXIMUM MOLD PROTRUSION 0.15 (0.006).
  5. ALL VERTICAL SURFACES 5° TYPICAL DRAFT.

DIM	INCHES		MILLIMETERS	
	MIN	MAX	MIN	MAX
A	0.658	0.668	16.71	16.97
B	0.541	0.551	13.74	13.99
C	0.209	0.231	5.31	5.87
D	0.046	0.054	1.17	1.37
F	0.037	0.053	0.94	1.34
G	0.100 BSC		2.54 BSC	
J	0.009	0.011	0.23	0.28
M	0°	7°	0°	7°
P	0.856	0.880	21.74	22.35
R	0.503	0.523	12.78	13.28
Y	0.002	0.010	0.05	0.25

- STYLE 1:  
 PIN 1. NC  
 2. VSUPPLY  
 3. GROUND  
 4. VOUT  
 5. NC  
 6. NC  
 7. NC  
 8. NC

**CASE 471-01  
 ISSUE O**

Motorola reserves the right to make changes without further notice to any products herein. Motorola makes no warranty, representation or guarantee regarding the suitability of its products for any particular purpose, nor does Motorola assume any liability arising out of the application or use of any product or circuit, and specifically disclaims any and all liability, including without limitation consequential or incidental damages. "Typical" parameters which may be provided in Motorola data sheets and/or specifications can and do vary in different applications and actual performance may vary over time. All operating parameters, including "Typicals" must be validated for each customer application by customer's technical experts. Motorola does not convey any license under its patent rights nor the rights of others. Motorola products are not designed, intended, or authorized for use as components in systems intended for surgical implant into the body, or other applications intended to support or sustain life, or for any other application in which the failure of the Motorola product could create a situation where personal injury or death may occur. Should Buyer purchase or use Motorola products for any such unintended or unauthorized application, Buyer shall indemnify and hold Motorola and its officers, employees, subsidiaries, affiliates, and distributors harmless against all claims, costs, damages, and expenses, and reasonable attorney fees arising out of, directly or indirectly, any claim of personal injury or death associated with such unintended or unauthorized use, even if such claim alleges that Motorola was negligent regarding the design or manufacture of the part. Motorola and are registered trademarks of Motorola, Inc. Motorola, Inc. is an Equal Opportunity/Affirmative Action Employer.

Mfax is a trademark of Motorola, Inc.

**How to reach us:**

**USA/EUROPE/Locations Not Listed:** Motorola Literature Distribution; P.O. Box 5405, Denver, Colorado 80217. 303-675-2140 or 1-800-441-2447

**JAPAN:** Nippon Motorola Ltd.; Tatsumi-SPD-JLDC, 6F Seibu-Butsuryu-Center, 3-14-2 Tatsumi Koto-Ku, Tokyo 135, Japan. 81-3-3521-8315

**Mfax™:** RMFAX0@email.sps.mot.com – TOUCHTONE 602-244-6609  
 – US & Canada ONLY 1-800-774-1848

**ASIA/PACIFIC:** Motorola Semiconductors H.K. Ltd.; 8B Tai Ping Industrial Park, 51 Ting Kok Road, Tai Po, N.T., Hong Kong. 852-26629298

**INTERNET:** <http://motorola.com/sps>

