

NPN SILICON PLANAR EPITAXIAL TRANSISTOR

2N6707

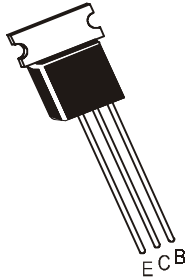

**TO-237
Plastic Package**

General Purpose Medium Power Amplifier

ABSOLUTE MAXIMUM RATINGS(Ta=25°C)

DESCRIPTION	SYMBOL	VALUE	UNIT
Collector Base Voltage	V_{CBO}	100	V
Collector Emitter Voltage	V_{CEO}	80	V
Emitter Base Voltage	V_{EBO}	5	V
Collector Current Continuous	I_C	1.5	A
Total Power Dissipation	P_D	850	mW
Operating And Storage Junction Temperature Range	T_j, T_{stg}	-55 to +150	°C

ELECTRICAL CHARACTERISTICS (Ta=25 ° C Unless Specified Otherwise)

DESCRIPTION	SYMBOL	TEST CONDITION	MIN	MAX	UNIT
Collector Emitter Voltage	V_{CEO}	$I_C=10mA, I_B=0$	80		V
Collector Base Voltage	V_{CBO}	$I_C=100\mu A, I_E=0$	100		V
Emitter-Base Voltage	V_{EBO}	$I_E=10\mu A, I_C=0$	5		V
Collector Cut off Current	I_{CBO}	$V_{CB}=100V, I_E=0$		0.1	μA
Emitter Cut off Current	I_{EBO}	$V_{EB}=4V, I_C=0$		0.1	μA
DC Current Gain	h_{FE}	$I_C=50mA, V_{CE}=2V$	40		
		$I_C=250mA, V_{CE}=2V$	40	250	
		$I_C=500mA, V_{CE}=2V$	25		
Collector Emitter Saturation Voltage	$V_{CE(sat)}$	$I_C=500mA, I_B=50mA$		0.5	V
		$I_C=1A, I_B=100mA$		1	V
Transition Frequency	f_T	$V_{CE}=10V, I_C=200mA,$	50	400	MHz

2N6707

TO-237
Plastic Package

TO-237 Plastic Package

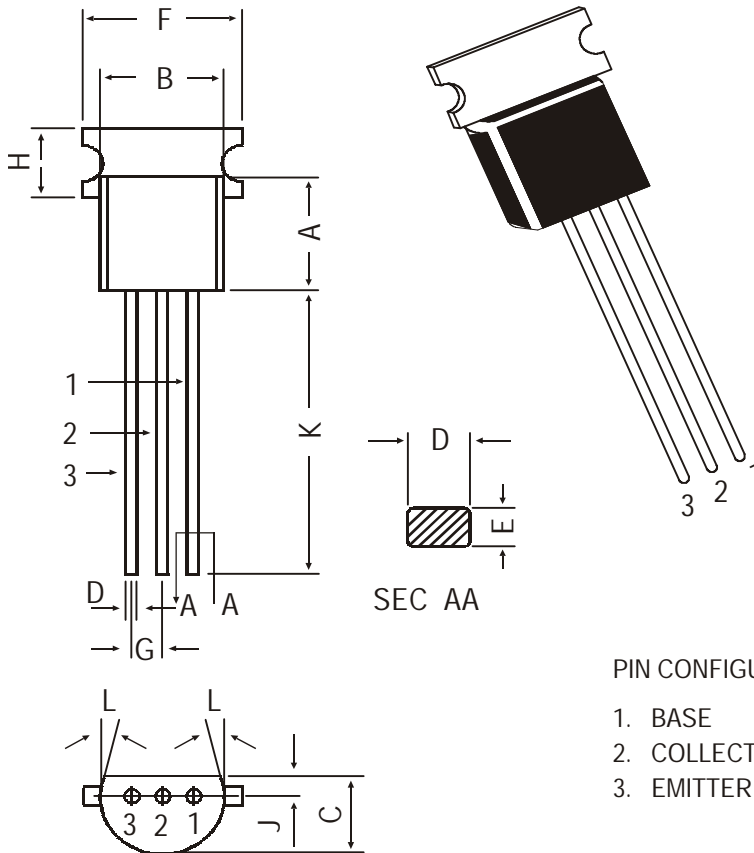

All dimensions in mm.

DIM	MIN.	MAX.
A	4.32	5.33
B	4.45	5.20
C	3.18	4.19
D	0.41	0.55
E	0.35	0.50
F	—	5.40
G	1.14	1.40
H	—	2.54
K	12.70	—
L	5 DEG	
J	1.14	1.53

PIN CONFIGURATION

- 1. BASE
- 2. COLLECTOR
- 3. EMITTER

Packing Detail

PACKAGE	STANDARD PACK		INNER CARTON BOX		OUTER CARTON BOX		
	Details	Net Weight/Qty	Size	Qty	Size	Qty	Gr Wt
TO-237 Bulk	1K/polybag	240 gm/1K pcs	3" x 7.5" x 7.5"	5K	17" x 15" x 13.5"	80K	26.2 kgs
TO-237 T&A	2K/ammo box	725 gm/2K pcs	12.5" x 8" x 1.8"	2K	17" x 15" x 13.5"	32K	13.8 kgs

Disclaimer

The product information and the selection guides facilitate selection of the CDIL's Discrete Semiconductor Device(s) best suited for application in your product(s) as per your requirement. It is recommended that you completely review our Data Sheet(s) so as to confirm that the Device(s) meet functionality parameters for your application. The information furnished in the Data Sheet and on the CDIL Web Site/CD is believed to be accurate and reliable. CDIL however, does not assume responsibility for inaccuracies or incomplete information. Furthermore, CDIL does not assume liability whatsoever, arising out of the application or use of any CDIL product; neither does it convey any license under its patent rights nor rights of others. These products are not designed for use in life saving/support appliances or systems. CDIL customers selling these products (either as individual Discrete Semiconductor Devices or incorporated in their end products), in any life saving/support appliances or systems or applications do so at their own risk and CDIL will not be responsible for any damages resulting from such sale(s).

CDIL strives for continuous improvement and reserves the right to change the specifications of its products without prior notice.



CDIL is a registered Trademark of

Continental Device India Limited

C-120 Naraina Industrial Area, New Delhi 110 028, India.

Telephone + 91-11-2579 6150, 5141 1112 Fax + 91-11-2579 5290, 5141 1119

email@cdil.com www.cdilsemi.com