



3006B

3036B

CMOS IC

T-74-05-01

# 3V-Operated Electronic Volume Control

1374C

Use : Attenuation of signal

**Features :**

- . C MOS process 3V typ. operation.
  - . Up/down operation is performed with SW input.
  - . 4-bit, 16-step counter. Step 6\* is set with initial input ( $\overline{INIT}$ ).
  - . Center tap provided.
  - . Maximum attenuation : -60dB or less
  - . Attenuation curve : Pseudo curve A. Left/right simultaneous setting.
- (Note) \* : Step 6 means mode 6.

TENTATIVE

**Absolute Maximum Ratings at Ta=25°C**

Parameter	Symbol	Value	unit
Maximum Supply Voltage	$V_{DDmax}$	$V_{SS}$ to 6	V
Applied Voltage	$V_I$	$V_{SS}$ to $V_{DD}$	V
Allowable Power Dissipation	$P_{dmax}$	100	mW
Operating Temperature	$T_{opg}$	-30 to +75	°C
Storage Temperature	$T_{stg}$	-40 to +125	°C

**Allowable Operating Conditions at Ta=25°C**

Parameter	Symbol	Value	unit
Supply Voltage	$V_{DD}$	2.1 to 4.5	V
Input "H" Level Voltage	$V_{IH}$	$0.7V_{DD}$ to $V_{DD}$	V
Input "L" Level Voltage	$V_{IL}$	0 to $0.3V_{DD}$	V

**Electrical Characteristics at Ta=25°C**

Signal Distortion	THD1	$V_{DD}=3V, R_L=50k\Omega, f=1kHz$	0.5% max
	THD2	$V_{DD}=1.8V, R_L=50k\Omega, f=1kHz$	1% typ
Output at Attenuation Mode	$X_{OUT}$	0dBm input, 1kHz, 51k $\Omega$ load	-60dB max



**Case Outline 3006B-D16IC LC7533**

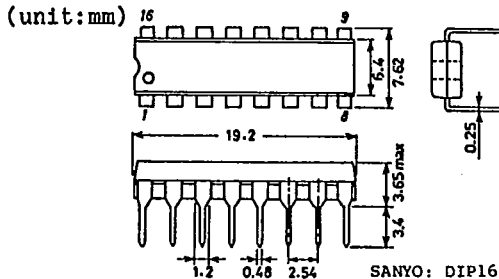

**Case Outline 3036B-M20IC LC7534M**

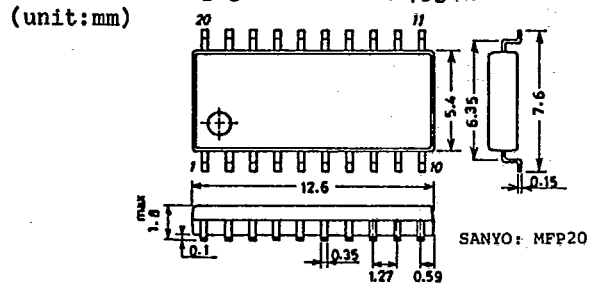

LC7533,7534M

T-74-05-01

Pin Assignment

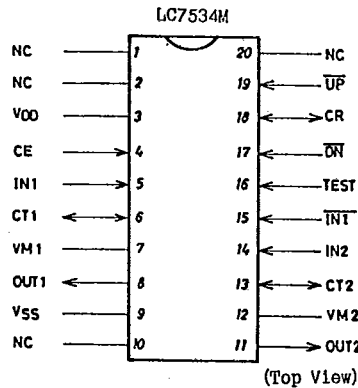
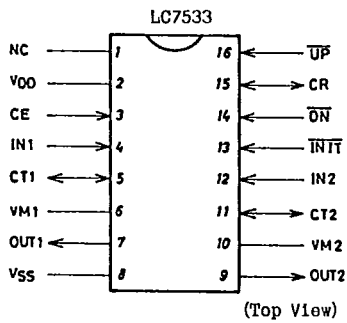

- Note 1. No bonding exists on the inside of NC pin. It is recommended that the outside should be shorted to  $V_{DD}$ ,  $V_{SS}$ , etc. on the printed circuit board.
- Note 2. The MFP package only is provided with the TEST pin. It should be connected to  $V_{SS}$ .  
 TEST=0 causes the power-on reset function to be performed.  
 (The power-on reset function means that mode 6 is entered at the time of application of power.)

Equivalent Circuit Block Diagram

Sample Application Circuit

Common to LC7533/LC7534M (LC7533 DIP-16)

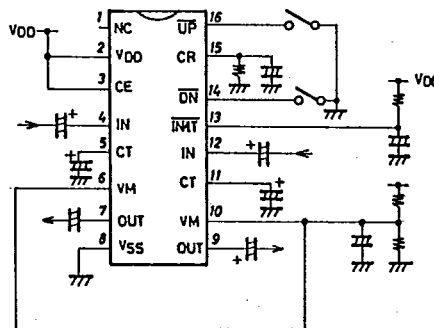
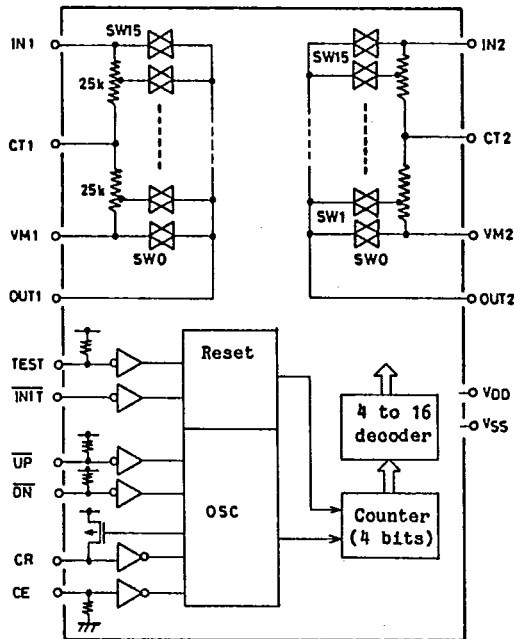

For  $V_M$ ,  $1/2V_{DD}$  bias is recommended.

Note 1. The TEST pin is bonded only when the MFP20 is used.

T-90-20

## AUDIO-USE MOS IC CASE OUTLINES

- All of Sanyo audio-use MOS IC case outlines are illustrated below.
- All dimensions are in mm, and dimensions which are not followed by min. or max. are represented by typical values.
- No marking is indicated.

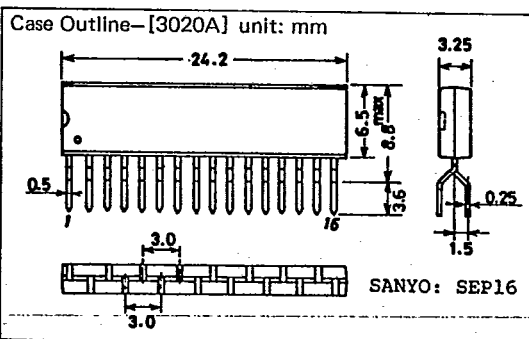
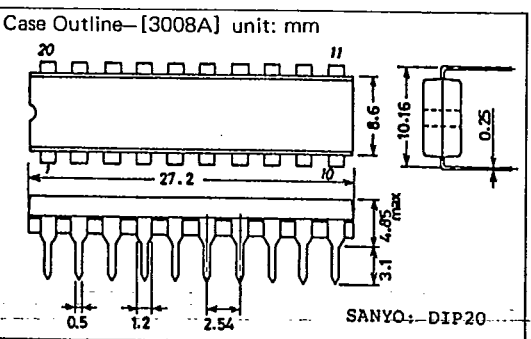
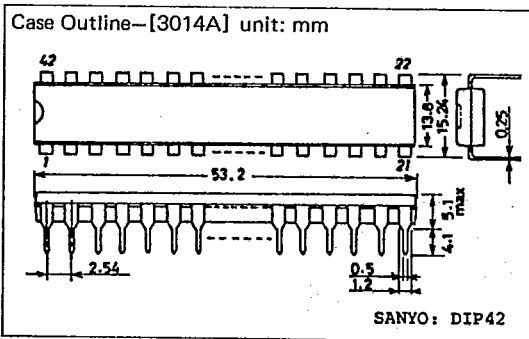
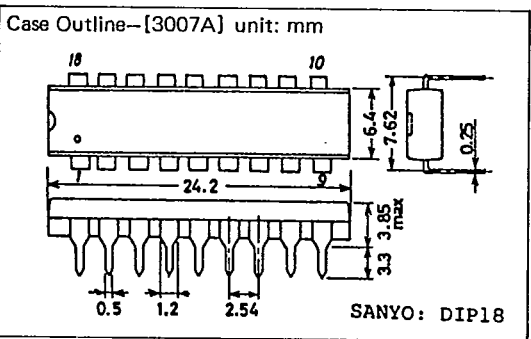
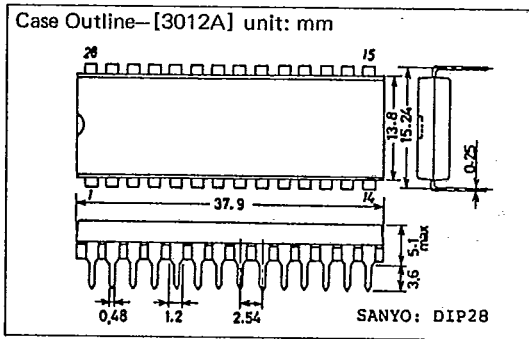
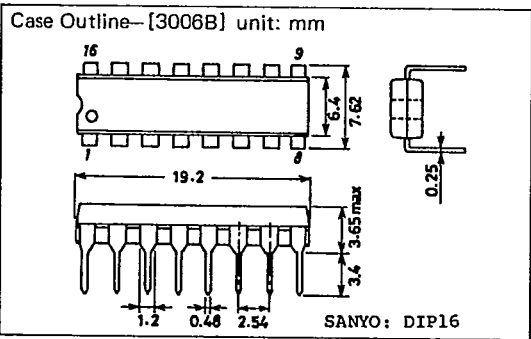
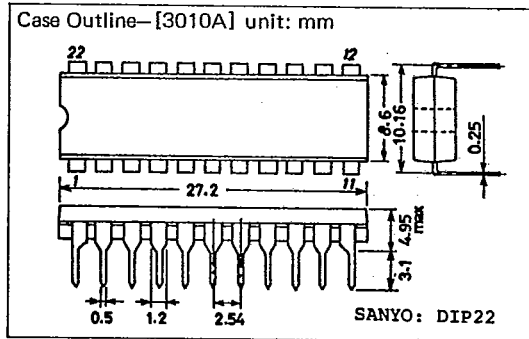
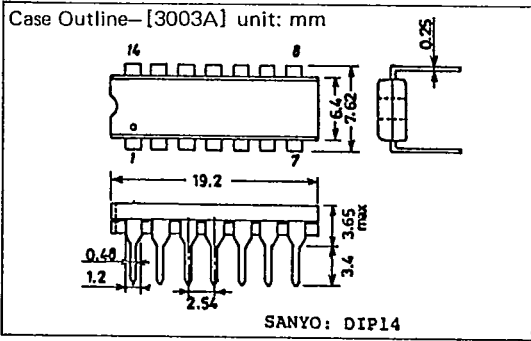



Case Outline-[3057] unit: mm

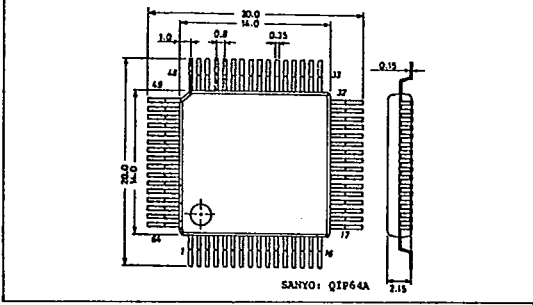

Case Outline-[3084] unit: mm

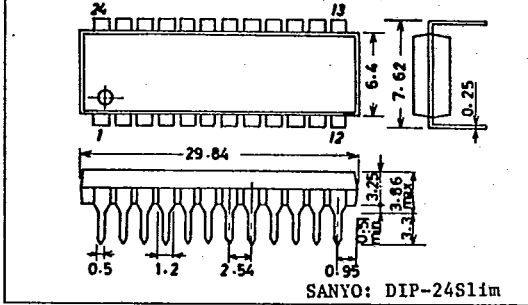

Case Outline-[3063] unit: mm

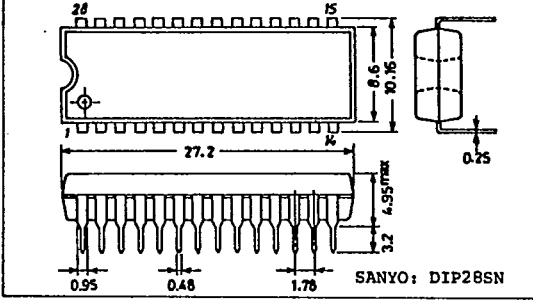

Case Outline-[3118] unit: mm

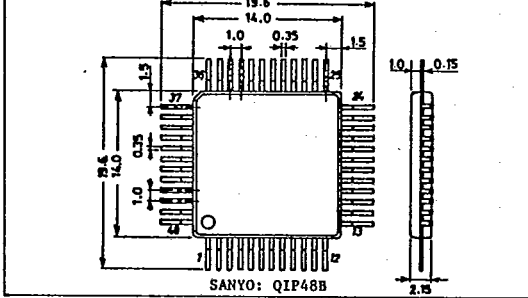

Case Outline-[3067] unit: mm

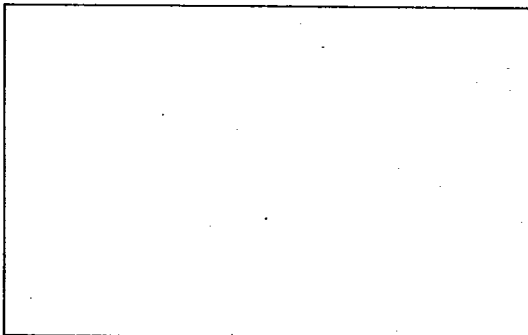
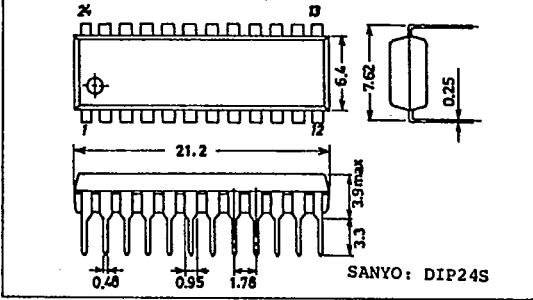

Case Outline-[3073A] unit: mm

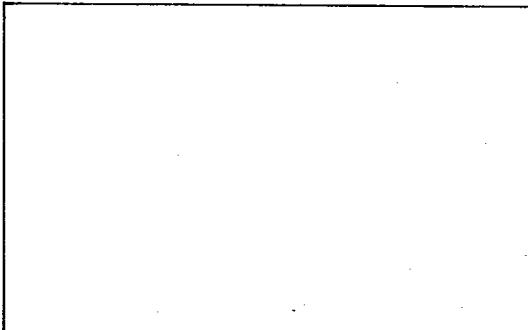
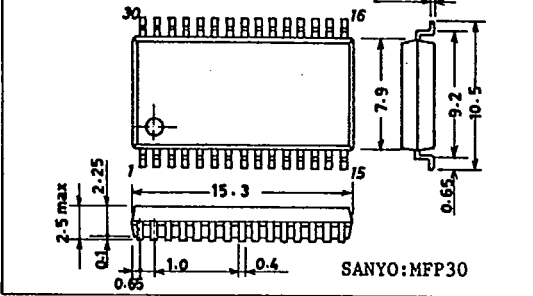

Case Outline-[3074] unit: mm

