

## GaAs MMIC SPDT NON-REFLECTIVE SWITCH, DC - 20.0 GHz

### Typical Applications

The HMC547LP3 is ideal for:

- Basestation Infrastructure
- Fiber Optics & Broadband Telecom
- Microwave Radio & VSAT
- Military Radios, Radar, & ECM
- Test Instrumentation

### Functional Diagram

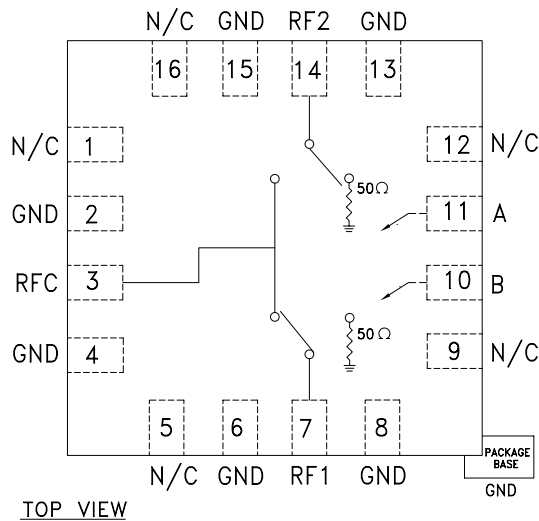

### Features

- High Isolation: >50 dB up to 5 GHz  
>45 dB up to 15 GHz
- Low Insertion Loss: 1.6 dB @ 10 GHz  
2.0 dB @ 20 GHz
- Fast Switching
- Non-Reflective Design
- QFN SMT Package, 9 mm<sup>2</sup>

### General Description

The HMC547LP3 is a general purpose broadband high isolation non-reflective GaAs MESFET SPDT switch in a low cost leadless QFN surface mount plastic package. Covering DC to 20 GHz, the switch offers high isolation and low insertion loss. The switch features >50 dB isolation up to 5 GHz and >45 dB isolation up to 15 GHz. The switch operates using complementary negative control voltage logic lines of -5/0V and requires no bias supply. The HMC547LP3 is packaged in a leadless QFN 3 x 3 mm surface mount package.

### Electrical Specifications, $T_A = +25^\circ \text{C}$ , With 0/-5V Control, 50 Ohm System

Parameter	Frequency	Min.	Typ.	Max.	Units
Insertion Loss	DC - 5.0 GHz		1.5	1.9	dB
	DC - 10.0 GHz		1.6	2.0	dB
	DC - 15.0 GHz		1.8	2.2	dB
	DC - 20.0 GHz		2.0	2.5	dB
Isolation	DC - 5.0 GHz	45	50		dB
	DC - 15.0 GHz	40	45		dB
	DC - 20.0 GHz	33	38		dB
Return Loss	"On State"		17		dB
Return Loss RF1, RF2	"Off State"		25		dB
	DC - 5.0 GHz		17		dB
	DC - 20.0 GHz		13		dB
Input Power for 1 dB Compression	0.5 - 20.0 GHz	20	23		dBm
Input Third Order Intercept (Two-Tone Input Power= +7 dBm Each Tone)	0.5 - 10.0 GHz		48		dBm
	0.5 - 20.0 GHz		45		dBm
Switching Characteristics	DC - 20 GHz	tRISE, tFALL (10/90% RF)	3		ns
		tON, tOFF (50% CTL to 10/90% RF)	6		ns

**GaAs MMIC SPDT NON-REFLECTIVE SWITCH, DC - 20.0 GHz**

**Insertion Loss**

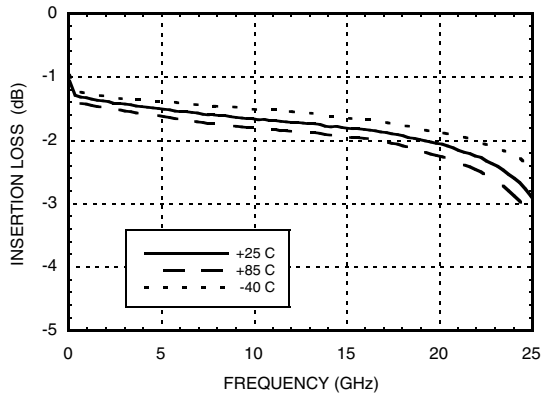

**Return Loss**

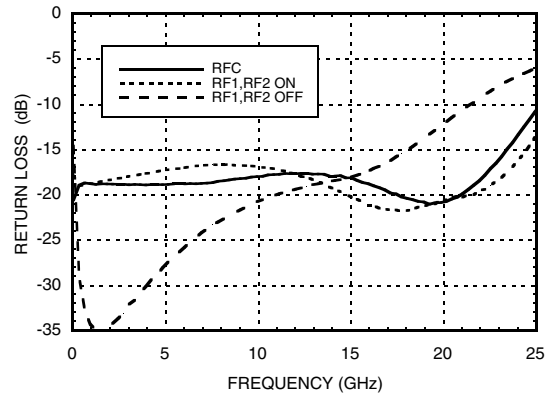

**Isolation Between Ports RFC and RF1/RF2**

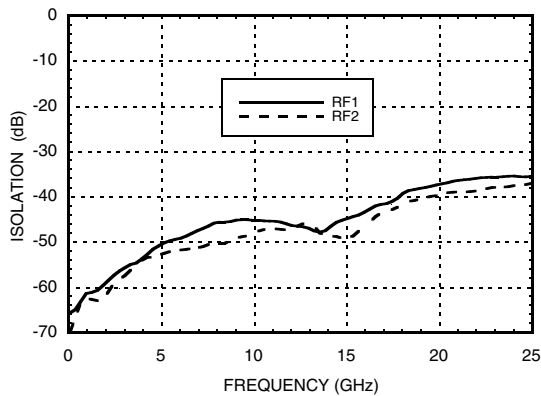

**Isolation Between Ports RF1 and RF2**

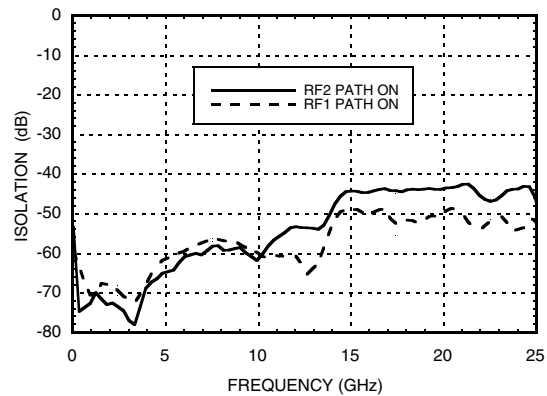

**Input P1dB and P0.1dB Compression Point**

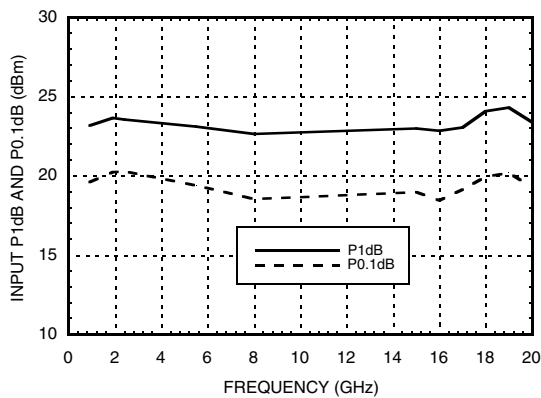

**Input Third Order Intercept Point**

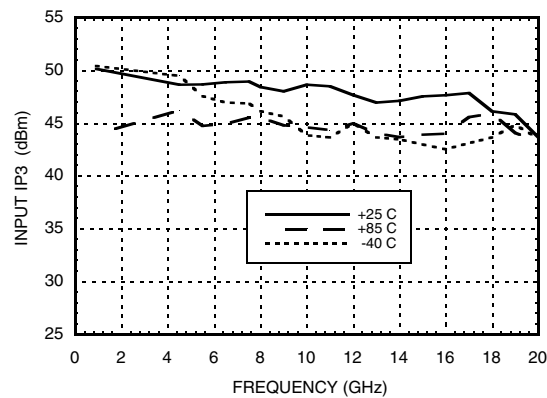

**GaAs MMIC SPDT NON-REFLECTIVE SWITCH, DC - 20.0 GHz**

**Absolute Maximum Ratings**

RF Input Power (Vctl = -5V)	+23 dBm
Control Voltage Range (A & B)	+0.5V to -7.5 Vdc
Hot Switch Power Level (Vctl = -5V)	+23 dBm
Channel Temperature	150 °C
Continuous P <sub>diss</sub> (T=85°C) (derate 4 mW/°C about 85°C)	0.26 W
Thermal Resistance (Insertion Loss Path)	420 °C/W
Thermal Resistance (Terminated Path)	250 °C/W
Storage Temperature	-65 to +150 °C
Operating Temperature	-55 to +85 °C
ESD Sensitivity (HBM)	Class 1C

**Control Voltages**

State	Bias Condition
Low	0 to -0.2V @ 10 uA Max.
High	-5V @ 3 uA Typ. to -7V @ 10 uA Typ. (± 0.5 Vdc)

**Truth Table**

Control Input		Signal Path State	
A	B	RFC to RF1	RFC to RF2
High	Low	On	Off
Low	High	Off	On

14



ELECTROSTATIC SENSITIVE DEVICE  
OBSERVE HANDLING PRECAUTIONS

**Outline Drawing**

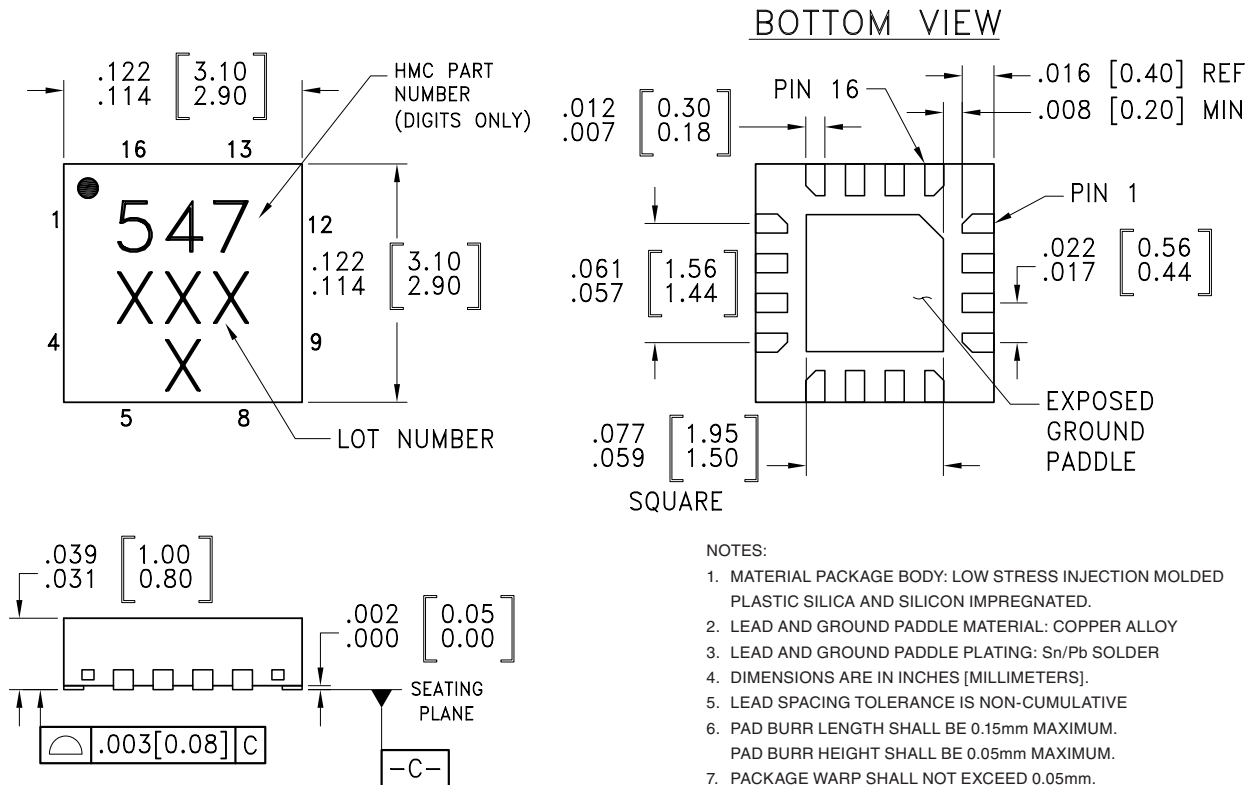

## GaAs MMIC SPDT NON-REFLECTIVE SWITCH, DC - 20.0 GHz

### Suggested Driver Circuit

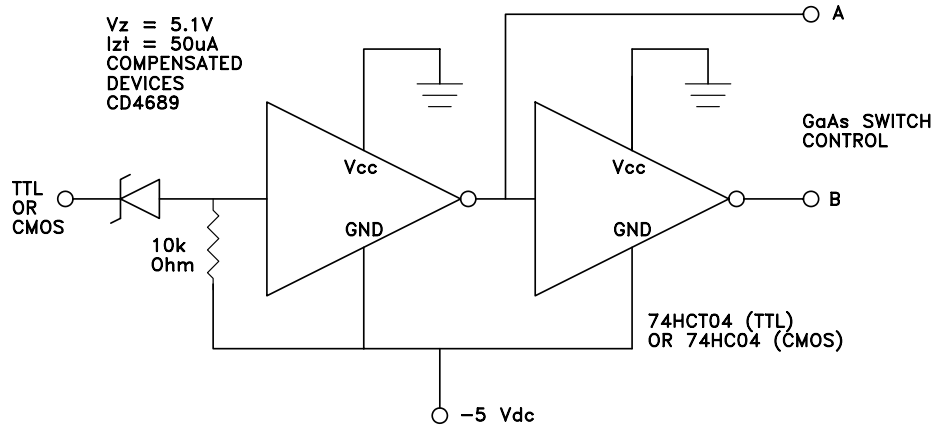

### Pin Descriptions

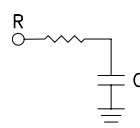
Pin Number	Function	Description	Interface Schematic
1, 5, 9, 12, 16	N/C	This pin should be connected to PCB RF ground to maximize isolation	
2, 4, 6, 8, 13, 15	GND	Package bottom has exposed metal paddle that must also be connected to PCB RF ground.	
3, 7, 14	RFC, RF1, RF2	This pin is DC coupled and matched to 50 Ohm. Blocking capacitors are required if RF line potential is not equal to 0V.	
10	B	See truth table and control voltage table.	
11	A	See truth table and control voltage table.	

**GaAs MMIC SPDT NON-REFLECTIVE SWITCH, DC - 20.0 GHz**

**Evaluation PCB**

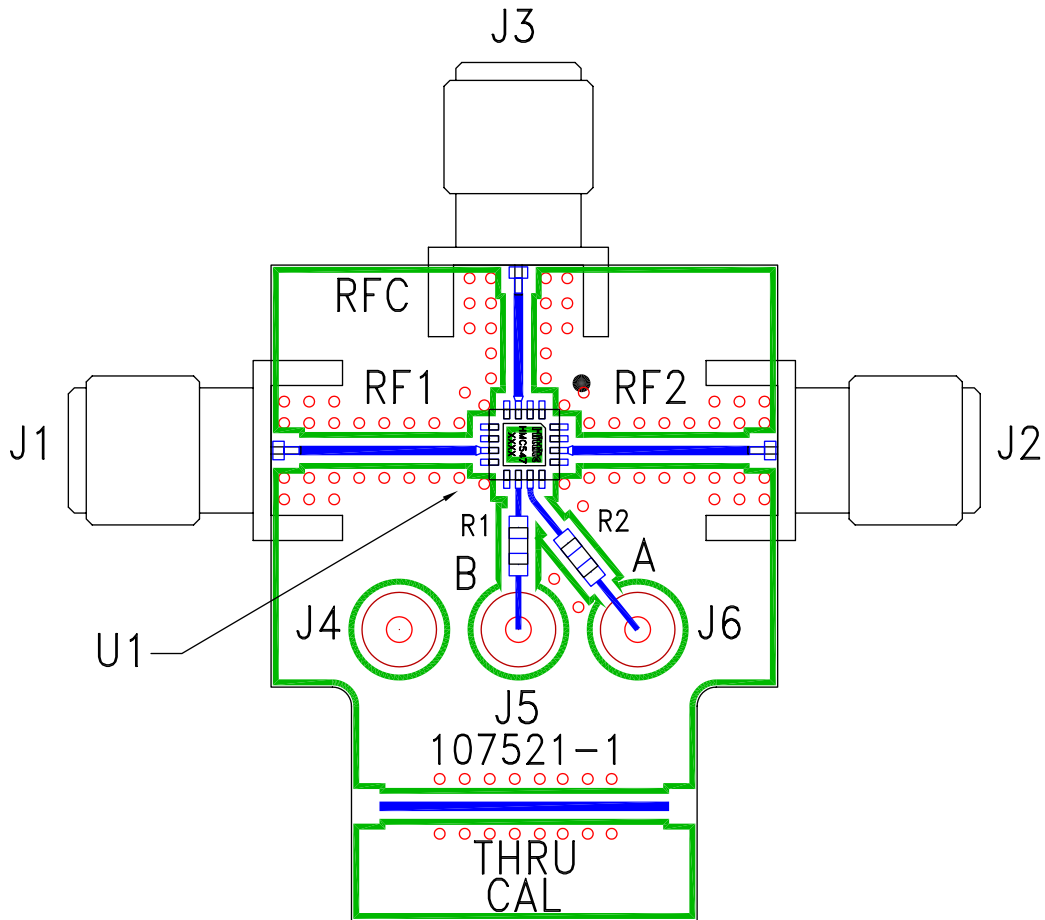

**List of Materials for Evaluation PCB 105711 [1]**

Item	Description
J1 - J3	PC Mount SRI SMA Connector
J4 - J6	DC Pin
R1 - R2	100 Ohm Resistor, 0603 Pkg.
U1	HMC547LP3 SPDT Switch
PCB [2]	107521 Evaluation PCB

[1] Reference this number when ordering complete evaluation PCB

[2] Circuit Board Material: Rogers 4350

The circuit board used in the final application should be generated with proper RF circuit design techniques. Signal lines at the RF port should have 50 ohm impedance and the package ground leads and package bottom should be connected directly to the ground plane similar to that shown above. The evaluation circuit board shown above is available from Hittite Microwave Corporation upon request.

***GaAs MMIC SPDT NON-REFLECTIVE  
SWITCH, DC - 20.0 GHz***

**Notes:**