

MOS INTEGRATED CIRCUIT

μ PD1703C-014

PLL FREQUENCY SYNTHESIZER AND CONTROLLER FOR FM AND AM TUNER

The μ PD1703C-014 is a CMOS LSI with built-in PLL and controller capable of receiving FM/AM in U.S.A. and Japan. The μ PD1703C-014 is provided in a shape of 28-pin DIP (Dual In-Line Package) with less substrate occupying area. In combination with a dedicated prescaler (μ PB553AC), the μ PD1703C-014 can be used to construct high fidelity FM/AM digital synthesizer tuners for home-stereo systems.

FEATURES

- FIP (Fluorescent Indicator Panel) direct drive (segments only)
- Built-in PLL frequency synthesizer, swallow counter, and controller
- Simple preset memory back-up (10 μ A or less: CE pin = low)
- Preset station display (LED dot display)
- FM reference frequency is as high as 25 kHz (pulse swallowing method used)
- U.S.A. and Japanese FM and AM bands selectable by initializing switch
- Independent 7-station preset memories for FM and AM
- Use of momentary or alternate switch for preset and band selector keys
- Separate last channel memories for FM and AM bands
- Automatic and manual UP/DOWN tuning (triangle wave tuning)
- Dynamic or LCD static display by initializing switch (serial data output for static display mode)
- Built-in EXTERNAL DATA PRESET function useful for mass production operations
- Built-in REC. CALL function (333.3 Hz pulse output from MUTE pin)
- FM IF offset capacity (4 ways by 25 kHz steps)
- Small 28-pin plastic DIP package (400 mil type) which occupies little circuit board space
- 5 V. \pm 10 % single power supply

FUNCTION

Receiving frequency, channel spacing, reference frequency, intermediate frequency

| | | FREQUENCY RANGE | CHANNEL SPACE | REFERENCE FREQUENCY | INTERMEDIATE FREQUENCY |
|--------|-----|-------------------|---------------|---------------------|------------------------------------|
| U.S.A. | AM1 | 530 to 1 620 kHz | 10 kHz | 10 kHz | 450 kHz |
| | AM2 | 531 to 1 602 kHz | 9 kHz | 9 kHz | |
| | FM1 | 87.9 to 107.9 MHz | 200 kHz | 25 kHz | 10.650, 10.675, 10.700, 10.725 MHz |
| | FM2 | 87.9 to 107.9 MHz | 100 kHz | 25 kHz | |
| Japan | AM | 531 to 1 602 kHz | 9 kHz | 9 kHz | 450 kHz |
| | FM | 76.0 to 90.0 MHz | 100 kHz | 25 kHz | 10.675, 10.700, 10.725, 10.750 MHz |

Tuning functions

(1) Auto UP/DOWN tuning (sawtooth wave mode)

Auto tuning is stopped when a high level input is applied to the SD pin. The frequency at that time remains tuned. The auto tuning direction is reversed when a band edge (the lowest or highest frequency in that band) is reached (that is, UP reversed to DOWN, and DOWN reversed to UP) and the auto tuning operation is continued.

(2) Manual UP/DOWN tuning (sawtooth wave mode)

Stepwise tuning by momentary switch. If pressed for more than 0.5 sec, tuned frequency is changed continuously until switch is released. Note that the tuning operation is stopped when a band edge is reached.

(3) Preset station memory call

AM Seven stations (to)

FM Seven stations (to)

Independent preset memories are used for AM and FM.

PIN CONFIGURATION (Top View)

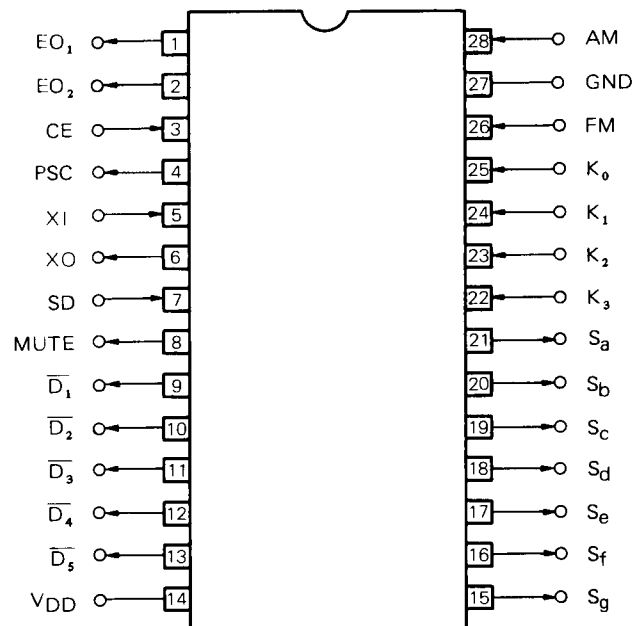

PIN DESCRIPTION

| PIN NO. | PIN SYMBOL | PIN NAME | DESCRIPTION |
|---------|--------------------------------------|-------------------------------|---|
| 1 2 | EO ₁ EO ₂ | Error out | PLL phase detector charge pump outputs. High level outputs are obtained from these pins if the frequency obtained by dividing the oscillator frequency is higher than the reference frequency, and low level outputs are obtained if the divided oscillator frequency is lower. The outputs are switched to floating status if the divided frequency is the same as the reference frequency. Since the same output signal is obtained from both EO ₁ and EO ₂ , either pin may be connected to the L.P.F. |
| 3 | CE | Chip enable | Device selector signal input pin. The CE pin is set to high level for normal device operation, and to low level if the device is not used. High level Normal operation Low level Memory hold status (display OFF, PLL operation halted, and internal clock operation stopped) Preset memory back-up is enabled at low power consumption current (below 10 μ A) by switching this pin to low level. Note that neither high nor low level pulses of less than 134 μ s are accepted. Also note that the rising edge of a high level pules applied to the CE pin must come after V _{DD} has reached high level (4.5 V min.), and a low level falling edge must be applied before V _{DD} reaches 4.5 V. |
| 4 | PSC | Pulse swallow- ing control | Output of signal for switching the prescalar frequency division factor for FM reception where pulse swallowing is used as the frequency division method. Connect to PSC pin of the μ PB553AC dedicated prescalar. The switchable μ PB553AC frequency division factors are 1/16 and 1/17. |
| 5 6 | XI XO | X'tal | Crystal resonator connector pins. Connect to a 4.5 MHz resonator. |
| 7 | SD | Station detector | Input pin used to determine when a broadcasting station is received during auto tuning (auto UP/DOWN). Apply a high level input signal within 75 msec after locking the PLL. |
| 8 | MUTE | MUTE | Active high output pin used to eliminate shock noise if the PLL comes un-locked. The MUTE pin is switched unconditionally to low level if the CE pin is at low level (back-up status). During AM/FM switching 800 msec. (approx.) During manual UP/DOWN tuning 200 msec. (approx.) (Single step operation) During auto UP/DOWN tuning 200 msec. (approx.) after high level input is applied to the SD pin During preset memory calls 450 msec. (approx.) These muting periods refer to the output periods after a change in PLL data. In actual circuits, approximately 50 msec. of "first out" (preceeding the PLL data change) is added to these values. See the MUTE output timing chart on page 27 for details. |
| 9 to 13 | \overline{D}_1 to \overline{D}_5 | Digit outputs | Display digits signal output pins (active low). (See the display description on page 20 for details.) |
| 14 | V _{DD} | V _{DD} | Device power supply pin A voltage of +5 V \pm 10 % is supplied during device operation, and this can be reduced to 2.5 V for back-up mode. The V _{DD} rise time must be less than 500 msec. The device may not be correctly initialized if the rise time is very long. |

| PIN NO. | PIN SYMBOL | PiN NAME | DESCRIPTION |
|----------|----------------------------------|-----------------------------------|--|
| 15 to 21 | S _a to S _g | Segment outputs | Display segment signal output and key return signal source pins (active high). (See page 6 for details on the key matrix.) Since this pin has a voltage endurance of 30 V, it may be connected directly to the FIP (fluorescent indicator panel) segment pins. (See the display section on page 20 for details.) |
| 22 to 25 | K ₀ to K ₃ | Key return signal inputs | Input pins for key return signals from an external key matrix. (See section on key matrix configuration on page 6 for details.) |
| 26 | FM | FM local oscillator signal inputs | The output obtained by dividing the FM local oscillator output by 16 or 17 (in the μ PB553AC prescaler) is applied to this pin. Because of the built-in AC amplifier, eliminate the DC components of the input by capacitor. |
| 27 | GND | GND | Connect to system ground. |
| 28 | AM | AM local oscillator signal inputs | The AM local oscillator output is applied to this input pin. Because of the built-in AC amplifier, eliminate the DC components of the input by capacitor. |

CONTENTS

| | |
|---|----|
| 1. KEY MATRIX | 6 |
| 1.1 CONFIGURATION OF KEY MATRIX | 6 |
| 1.2 KEY MATRIX CONNECTIONS AND SWITCH FORMATS | 7 |
| 1.3 DESCRIPTION OF KEY MATRIX | 10 |
| 2. FM/AM POWER SWITCHING CIRCUIT EXAMPLE | 15 |
| 3. DESCRIPTION OF EXTERNAL DATA PRESET | 16 |
| 4. DESCRIPTION OF THE DISPLAY | 20 |
| 4.1 DYNAMIC DISPLAY | 20 |
| 4.2 STATIC DISPLAY | 22 |
| 5. PRESET STATION DISPLAY | 24 |
| 6. TIMING CHARTS | 26 |
| 6.1 DISPLAY AND KEY INPUT ACCEPTANCE | 26 |
| 6.2 MUTE TIMING CHARTS | 27 |
| 7. APPRICATION CIRCUIT | 28 |
| 8. ELECTRICAL CHARACTERISTICS | 29 |
| 8.1 ABSOLUTE MAXIMUM RATINGS | 29 |
| 8.2 RECOMMENDED OPERATING CONDITIONS | 29 |
| 8.3 DC CHARACTERISTICS | 29 |
| 8.4 AC CHARACTERISTICS | 30 |
| 9. PACKAGE DIMENSIONS | 31 |

1. KEY MATRIX

1.1 CONFIGURATION OF KEY MATRIX

| Input Output | K ₀ (25) | K ₁ (24) | K ₂ (23) | K ₃ (22) |
|---------------------|---------------------|---------------------|---------------------|---------------------|
| S _a (21) | DOWN | UP | MEMORY | EXT. DATA PRESET |
| S _b (20) | M4 | M3 | M2 | M1 |
| S _c (19) | | M7 | M6 | M5 |
| S _d (18) | | | FM | AM |
| S _e (17) | | | | |
| S _f (16) | 100 k/200 k | STATIC/DYNA | AUTO/MANUAL | REC. CALL |
| S _g (15) | USA/JPN(FM) | 10 kHz/9 kHz(AM) | IF1 | IF0 |

(): Pin number

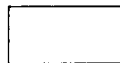

: Momentary switch

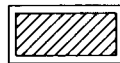

: Momentary or alternate switch

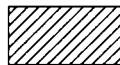

: Alternate switch



: Diode matrix (shorted or opened by diode)

1.2 KEY MATRIX CONNECTIONS AND SWITCH FORMATS

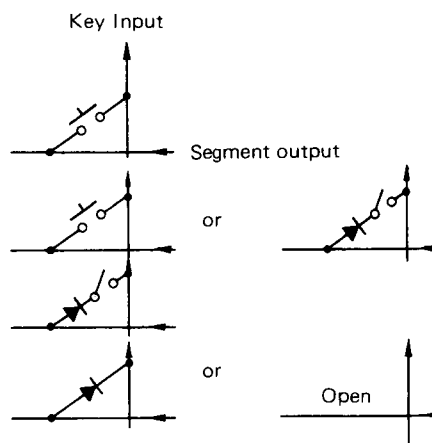
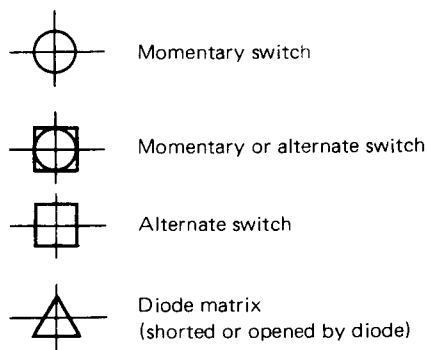
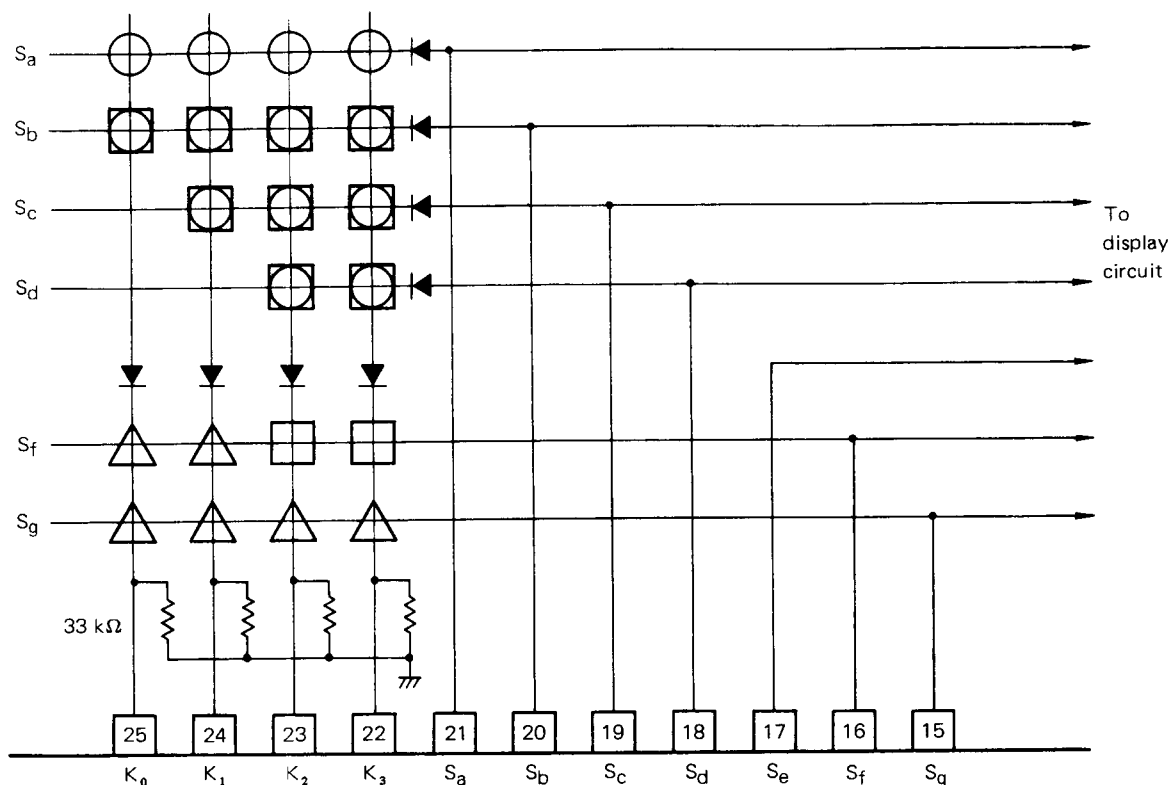

The preset keys (to) and the band selector keys (AM, FM) may be either momentary or alternate switches. Note, however, that the insertion positions of the diodes (used to prevent the key return signals from taking roundabout routes) differ according on the type of switch used. A number of examples are given below.

Example 1. When momentary switches are used as preset keys and band selector keys.

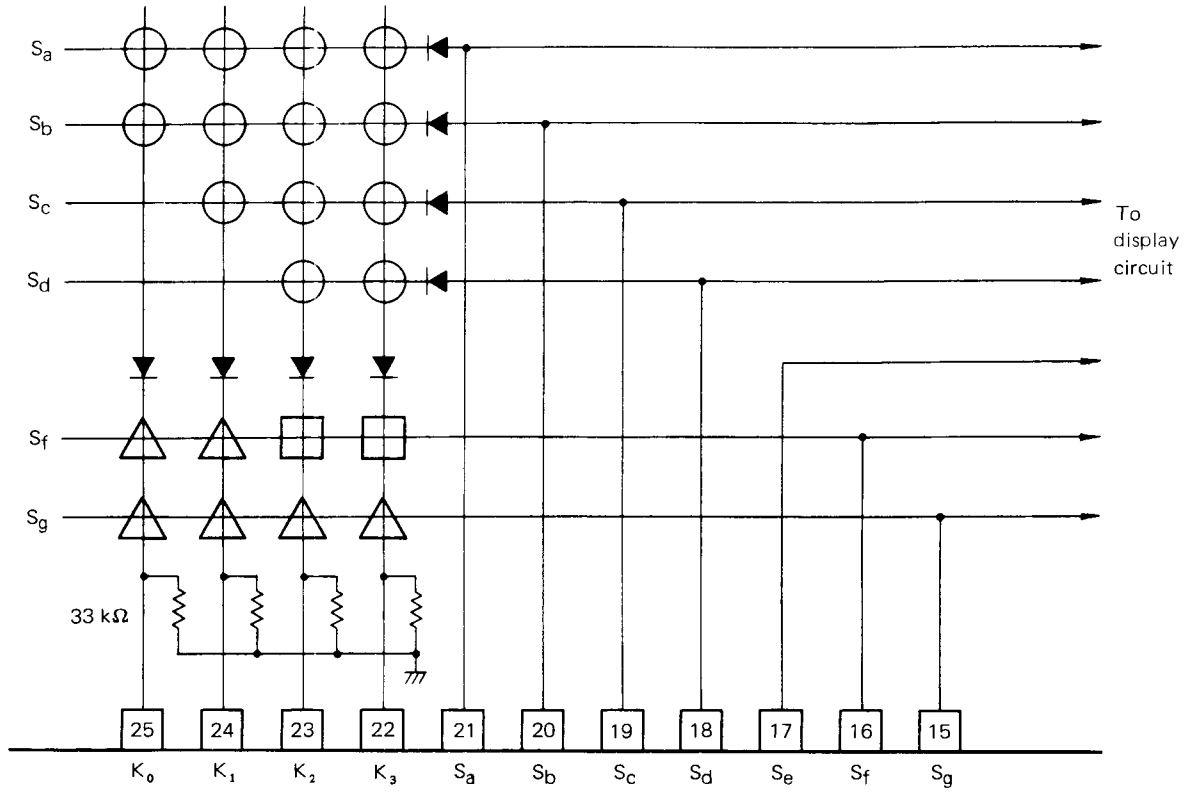

Example 2. When alternate switches are used as band selector keys.

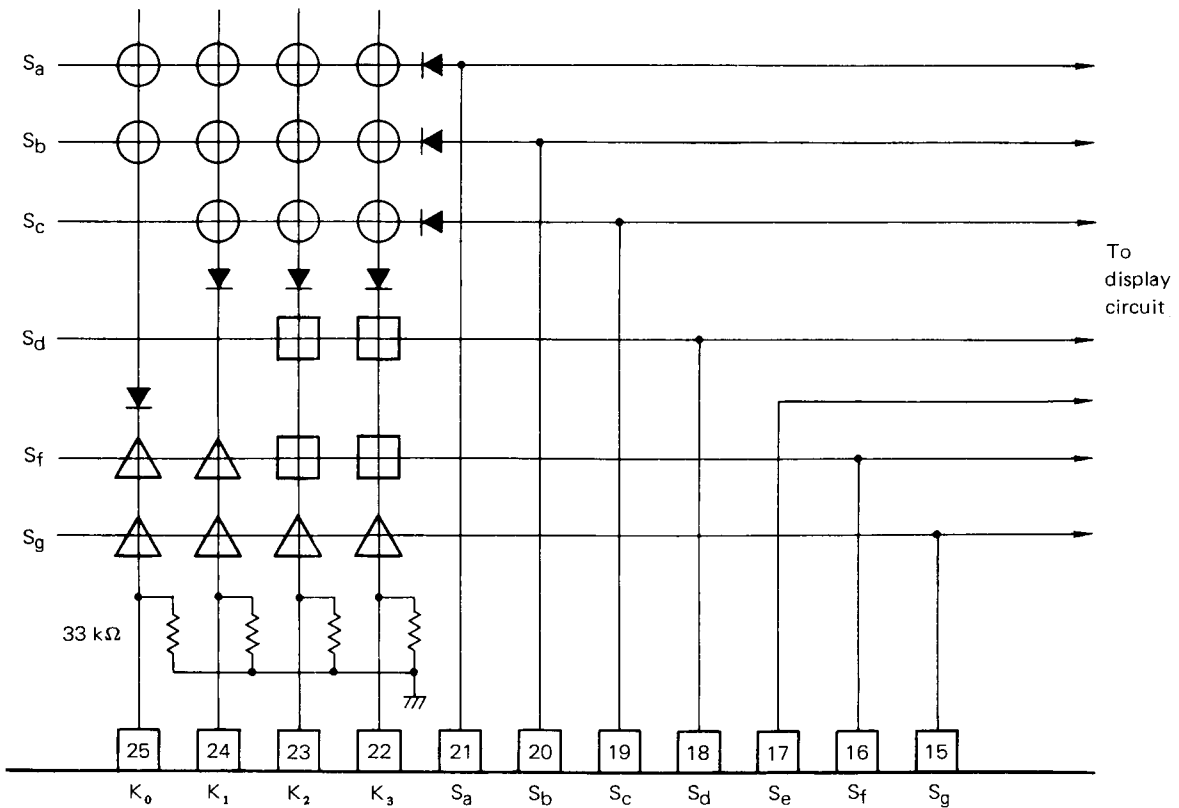

Example 3. When alternate switches are used as preset keys and band keys.

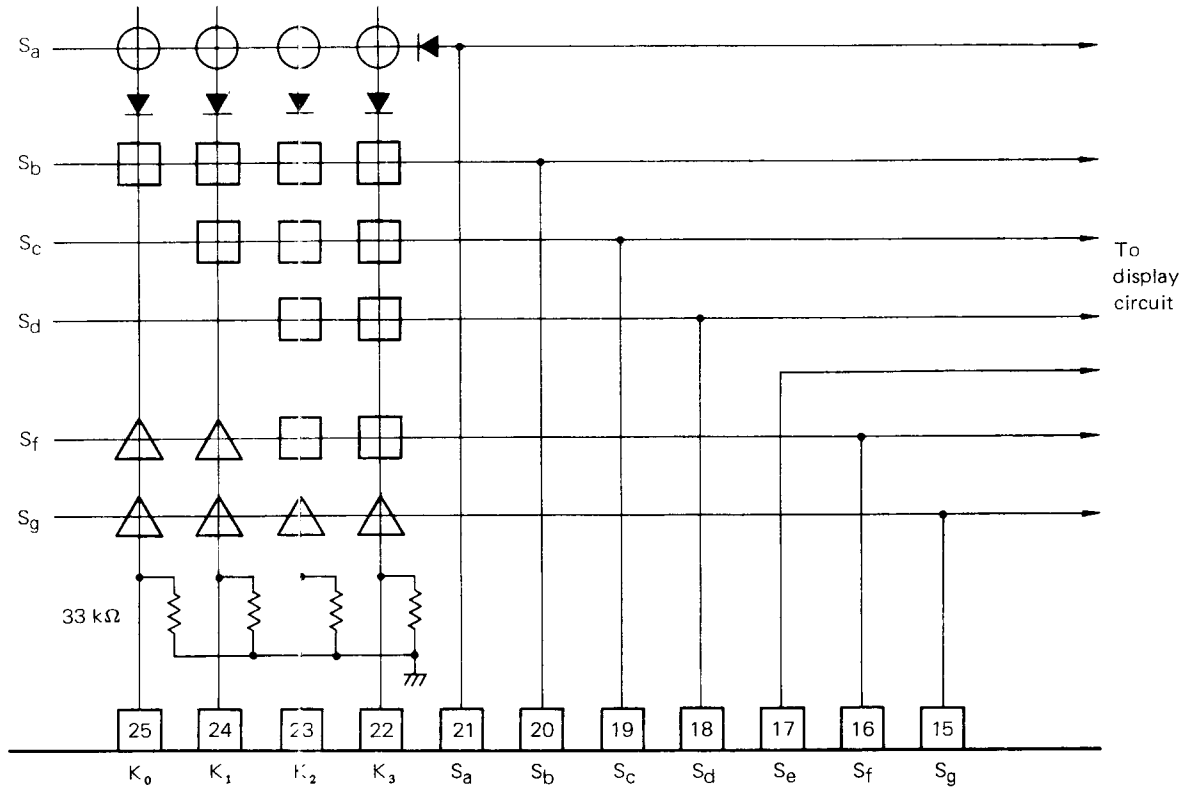

1.3 DESCRIPTION OF KEY MATRIX

1.3.1 Initialization Diode Matrix

The five types of initialization diode matrix are outlined below. The status of this diode matrix is read when the power is applied to the V_{DD} pin (initialization) and when the CE pin status is changed from low to high level. And although the status of 100 k/200 k and STATIC/DYNAMIC switches is read constantly, the PLL data and display are changed only when a momentary switch (UP, DOWN, M1 to M7) is pressed.

- (1) FM IF offset setting switch
IF1, IF0
- (2) AM band channel space and reference frequency setting switch
9 kHz/10 kHz (AM)
- (3) FM band country (U.S.A./Japan) setting switch
USA/JPN
- (4) U.S.A. FM band channel space setting switch
100 kHz/200 kHz
- (5) Static and dynamic display setting switch
STATIC/DYNA

These settings are made by either shorting or opening the intersections in the matrix. (In the following tables, 1 denotes "shorted by diode" and 0 denotes "opened by diode".)

| SYMBOL | FUNCTION | | | | | | | | | | | | | | | | | | | | |
|-------------------------|---|-------------------|---------------------|-----------------|---------------------|---------|-------------------|------------------|------------|---|------------------|-------------------|-------------|---|---|------------|------------|---|---|------------|------------|
| <p>IF1 IF0</p> | <p>FM IF offset setting switches. The intermediate frequency can be set to the following four values in 25 kHz steps without changing the display frequency.</p> <table border="1" data-bbox="434 327 887 542"> <thead> <tr> <th>IF1</th> <th>IF0</th> <th>U.S.A. band</th> <th>Japanese band</th> </tr> </thead> <tbody> <tr> <td>0</td> <td>0</td> <td>10.700 MHz</td> <td>10.700 MHz</td> </tr> <tr> <td>0</td> <td>1</td> <td>10.725 MHz</td> <td>10.675 MHz</td> </tr> <tr> <td>1</td> <td>0</td> <td>10.650 MHz</td> <td>10.750 MHz</td> </tr> <tr> <td>1</td> <td>1</td> <td>10.675 MHz</td> <td>10.725 MHz</td> </tr> </tbody> </table> | IF1 | IF0 | U.S.A. band | Japanese band | 0 | 0 | 10.700 MHz | 10.700 MHz | 0 | 1 | 10.725 MHz | 10.675 MHz | 1 | 0 | 10.650 MHz | 10.750 MHz | 1 | 1 | 10.675 MHz | 10.725 MHz |
| IF1 | IF0 | U.S.A. band | Japanese band | | | | | | | | | | | | | | | | | | |
| 0 | 0 | 10.700 MHz | 10.700 MHz | | | | | | | | | | | | | | | | | | |
| 0 | 1 | 10.725 MHz | 10.675 MHz | | | | | | | | | | | | | | | | | | |
| 1 | 0 | 10.650 MHz | 10.750 MHz | | | | | | | | | | | | | | | | | | |
| 1 | 1 | 10.675 MHz | 10.725 MHz | | | | | | | | | | | | | | | | | | |
| <p>10 kHz/9 kHz</p> | <p>Switch for setting AM band channel spacing, reference frequency, and frequency range. This setting is made independent of the FM band country (U.S.A. /JPN).</p> <table border="1" data-bbox="434 685 1267 816"> <thead> <tr> <th>10 kHz/9 kHz</th> <th>Frequency range</th> <th>Channel spacing</th> <th>Reference frequency</th> </tr> </thead> <tbody> <tr> <td>0</td> <td>531 to 1 602 kHz</td> <td>9 kHz</td> <td>9 kHz</td> </tr> <tr> <td>1</td> <td>530 to 1 620 kHz</td> <td>10 kHz</td> <td>10 kHz</td> </tr> </tbody> </table> | 10 kHz/9 kHz | Frequency range | Channel spacing | Reference frequency | 0 | 531 to 1 602 kHz | 9 kHz | 9 kHz | 1 | 530 to 1 620 kHz | 10 kHz | 10 kHz | | | | | | | | |
| 10 kHz/9 kHz | Frequency range | Channel spacing | Reference frequency | | | | | | | | | | | | | | | | | | |
| 0 | 531 to 1 602 kHz | 9 kHz | 9 kHz | | | | | | | | | | | | | | | | | | |
| 1 | 530 to 1 620 kHz | 10 kHz | 10 kHz | | | | | | | | | | | | | | | | | | |
| <p>USA/JPN</p> | <p>Selector switch for country setting. The FM band for either the USA or Japan can be set.</p> <table border="1" data-bbox="434 919 1267 1050"> <thead> <tr> <th>USA/JPN</th> <th>Band area</th> <th>Frequency range</th> <th>Channel spacing</th> </tr> </thead> <tbody> <tr> <td>0</td> <td>Japanese band</td> <td>76.0 to 90.0 MHz</td> <td>100 kHz</td> </tr> <tr> <td>1</td> <td>U.S.A. band</td> <td>87.9 to 107.9 MHz</td> <td>200/100 kHz</td> </tr> </tbody> </table> <p>Channel space can be selected by the 100 k/200 k switch when the U.S.A. band is selected.</p> | USA/JPN | Band area | Frequency range | Channel spacing | 0 | Japanese band | 76.0 to 90.0 MHz | 100 kHz | 1 | U.S.A. band | 87.9 to 107.9 MHz | 200/100 kHz | | | | | | | | |
| USA/JPN | Band area | Frequency range | Channel spacing | | | | | | | | | | | | | | | | | | |
| 0 | Japanese band | 76.0 to 90.0 MHz | 100 kHz | | | | | | | | | | | | | | | | | | |
| 1 | U.S.A. band | 87.9 to 107.9 MHz | 200/100 kHz | | | | | | | | | | | | | | | | | | |
| <p>100 k/200 k</p> | <p>FM band channel space selector switch when used in the U.S.A. This switch can only be used when the country selector switch is set to U.S.A.</p> <table border="1" data-bbox="434 1230 1046 1361"> <thead> <tr> <th>100 k/200 k</th> <th>Channel spacing</th> <th>Frequency range</th> </tr> </thead> <tbody> <tr> <td>0</td> <td>200 kHz</td> <td rowspan="2">87.9 to 107.9 MHz</td> </tr> <tr> <td>1</td> <td>100 kHz</td> </tr> </tbody> </table> | 100 k/200 k | Channel spacing | Frequency range | 0 | 200 kHz | 87.9 to 107.9 MHz | 1 | 100 kHz | | | | | | | | | | | | |
| 100 k/200 k | Channel spacing | Frequency range | | | | | | | | | | | | | | | | | | | |
| 0 | 200 kHz | 87.9 to 107.9 MHz | | | | | | | | | | | | | | | | | | | |
| 1 | 100 kHz | | | | | | | | | | | | | | | | | | | | |
| <p>STATIC/ DYNA</p> | <p>Switch for setting the display to static or dynamic mode. 0 Dynamic display 1 Static display</p> <p>When set to static display, the DATA signal is obtained from the segment Sc pin, the CLOCK signal from the \overline{D}_1 pin, and the LOAD signal from the \overline{D}_2 pin. (See the display description on page 20 for details.)</p> | | | | | | | | | | | | | | | | | | | | |

1.3.2 Alternate Switches

The following two types of alternate switches available can be switched at any time.

- (1) Recording level check oscillator output selector switch

REC CALL

- (2) Auto/manual tuning selector switch

AUTO/MANUAL

| SYMBOL | FUNCTION |
|-----------------|--|
| REC CALL | <p>Recording level check oscillator output selector switch.</p> <p>A 333.3 Hz pulse putout is obtained from the MUTE pin when REC CALL is switched ON.</p> <p>ON (1) 333.3 Hz pulse output (display OFF)</p> <p>OFF (0) . . . Normal operation</p> <p>No other switch can be used during REC CALL operations.</p> <p>This oscillator output is also used in adjustment of the crystal resonator oscillating frequency (4.5 MHz) where an oscillating frequency adjuster capacitor is adjusted to obtain a frequency of 333.333 Hz.</p> |
| AUTO/ MANUAL | <p>Auto/manual tuning selector switch</p> <p>ON (1) Auto tuning</p> <p>OFF (0) . . . Manual tuning</p> <p>Auto and manual tuning is activated pressing the UP or DOWN momentary switch after this AUTO/MANUAL switch has been set. (See the section on momentary and alternate/ switches on page 13 for details.)</p> <p>Note 1. No change occurs if the AUTO/MANUAL switch is switched to the MANUAL position after auto tuning has been commenced. To halt auto tuning when switching to manual mode, a high level input signal must be applied constantly to the SD pin during manual mode.</p> <p>Note 2. Since the PLL lock status is detected during auto tuning, a defective PLL system may result in tuning failure or unsteady operation (such as different scanning speeds for each channel). If the tuning operation fails to start, apply a low level signal to the CE pin temporarily before returning to high level.</p> |

1.3.3 Momentary and Alternate Switches

The preset keys (to) and the band selector keys (AM, FM) may be either momentary or alternate switches. However, if alternate switches are used for the preset keys, the and keys must be interlinked with the preset key operations.

| SYMBOL | FUNCTION |
|--|---|
| <input type="text" value="EXTERNAL DATA PRESET"/> | <p>Writing of adjustment frequency data from an external microprocessor (such as TK-80) into the AM and FM preset memories (<input type="text" value="M1"/> to <input type="text" value="M7"/>) during mass production of tuners is activated by this switch.</p> <p>The following six pins are used in the transfer of data.</p> <p>K_0 to K_3 . . . Frequency data input pins (4-bit parallel inputs)</p> <p>MUTE Data request signal output pin</p> <p>SD Data acknowledge signal input pin</p> <p>(See the EXTERNAL DATA PRESET description on page 16 for details.)</p> |
| <input type="text" value="MEMORY"/> | <p>Memory switch is used to write fresh frequency data into preset memories.</p> <p>If one of the preset memory keys (<input type="text" value="M1"/> to <input type="text" value="M7"/>) is pressed within five seconds after pressing the MEMORY key, the displayed frequency is stored in the memory corresponding to that key.</p> <p>To release the memory write-enable state, push UP/DOWN Key or AM/FM Band switch.</p> |
| <input type="text" value="UP"/> <input type="text" value="DOWN"/> | <p>Auto and manual tuning keys. The operations outlined below are activated by pressing these keys.</p> <p>(1) When AUTO/MANUAL switch is set to the AUTO position</p> <ul style="list-style-type: none"> ○ Frequency is increased continuously at a rate of 80 msec./step when the <input type="text" value="UP"/> key is pressed. The frequency is likewise decreased continuously after the band edge is reached. (Sawtooth wave mode) <p>If a high level input is applied to the SD pin when the band edge is reached, auto tuning is stopped. And if the <input type="text" value="DOWN"/> key is pressed while the frequency is being increased, the frequency change is immediately reversed.</p> <ul style="list-style-type: none"> ○ Frequency is decreased continuously at a rate of 80 msec./step when the <input type="text" value="DOWN"/> key is pressed. The frequency is likewise increased continuously after the band edge is reached. (Sawtooth wave mode) <p>If a high level input is applied to the SD pin when the band edge is reached, auto tuning is stopped. And if the <input type="text" value="UP"/> key is pressed while the frequency is being decreased, the frequency change is immediately reversed.</p> <p>* The auto tuning operation continues unchanged if the <input type="text" value="UP"/> key is pressed during frequency increase, or if the <input type="text" value="DOWN"/> key is pressed during frequency decrease. Also note that auto tuning is not stopped if the <input type="text" value="UP"/> or <input type="text" value="DOWN"/> key remains depressed when a high level input is applied to the SD pin.</p> <p>(2) When AUTO/MANUAL switch is set to the AUTO position</p> <ul style="list-style-type: none"> ○ The frequency is increased or decreased in single steps (channel space) each time the <input type="text" value="UP"/> or <input type="text" value="DOWN"/> key is pressed. ○ If the <input type="text" value="UP"/> or <input type="text" value="DOWN"/> key is pressed for more than 0.5 seconds, the frequency is increased or decreased at a rate of 80 msec./step until the key is released. |

| SYMBOL | FUNCTION |
|---|---|
| <div style="border: 1px solid black; padding: 2px; width: fit-content; margin-bottom: 2px;">UP</div> <div style="border: 1px solid black; padding: 2px; width: fit-content;">DOWN</div> | <p>* Manual tuning is stopped when the band edge (the lowest or highest frequency in that band) is reached.</p> <p>Note: Auto tuning is not stopped if the AUTO/MANUAL switch is switched to the MANUAL position during auto tuning. To halt auto tuning when switching to manual mode, a high level input signal must be applied constantly to the SD pin during manual mode.</p> |
| <div style="border: 1px solid black; padding: 2px; width: fit-content; margin-bottom: 2px;">M1</div> <p style="text-align: center;">to</p> <div style="border: 1px solid black; padding: 2px; width: fit-content;">M7</div> | <p>Preset memory write and call keys Each key is linked to independent memories for AM and FM.</p> <p>(1) Memory write If one of the Preset memory keys (M1 to M7) is pressed within five seconds after pressing the MEMORY key, a new frequency is stored in the memory corresponding to that key.</p> <p>(2) Memory call Memory contents (frequency data) can be retrieved by pressing the Preset memory key (M1 to M7) corresponding to that memory. Pressing one of the preset keys at this time results in output of a muting signal of about 450 msec. duration. (See the mute timing chart on page 27 for details.)</p> <p>* The lowest FM frequency is called when V_{DD} is first activated. If preset memory calling is performed at this stage, the lowest frequencies in each band (AM and FM) are called.</p> |
| <div style="border: 1px solid black; padding: 2px; width: fit-content; margin-bottom: 2px;">AM</div> <div style="border: 1px solid black; padding: 2px; width: fit-content;">FM</div> | <p>AM/FM band selector switches. These switches may be a momentary or alternate switch. A muting signal of approximately 850 msec. duration is generated when switching bands.</p> |

2. FM/AM POWER SWITCHING CIRCUIT EXAMPLE

If a momentary switch is used for AM/FM band switching, the tuner power supply can be switched on and off by using the following circuit.

In this diagram, character display ("FM" and "AM") signals are used as the input signals, and an active high signal obtained from the μ PD1703C-014 digit pin \overline{D}_5 via a buffer stage (PNP transistor etc.) is used as the CLOCK signal (\overline{D}_5).

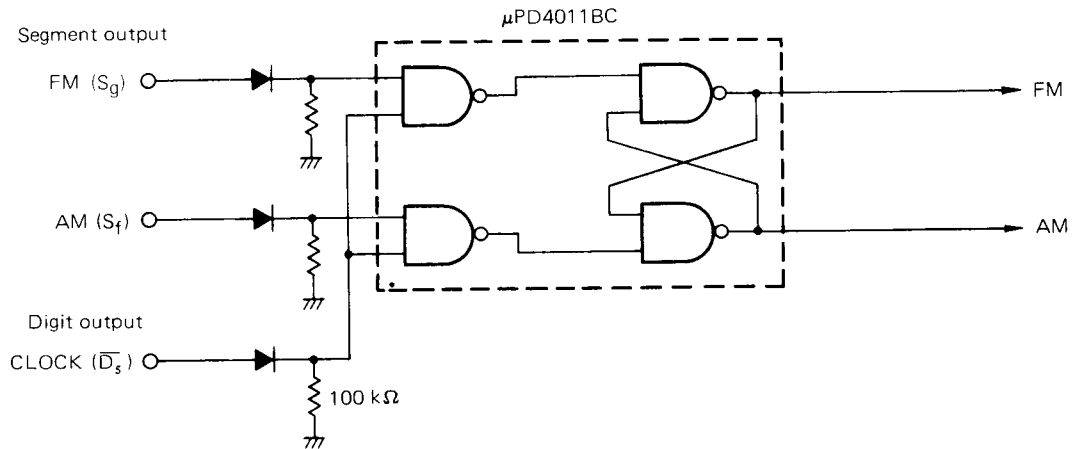

3. DESCRIPTION OF EXTERNAL DATA PRESET

The external data preset function is used to transfer frequency data (8 bits) from an external personal computer to the μ PD1703C-014 key inputs (K_0 to K_3) and subsequently write that data into FM or AM preset memory (M1 to M7).

Input of this frequency data is achieved by applying the eight bits of channel no. (see Table 1) corresponding to the frequency in two groups of four bits each (DATA H and DATA L). Any frequency value within the specified frequency ranges (87.9 to 107.9 MHz for FM and 530 to 1 620 kHz for AM in the U.S.A.) can be stored.

The μ PD1703C-014 flow chart is given in Figure 1 below.

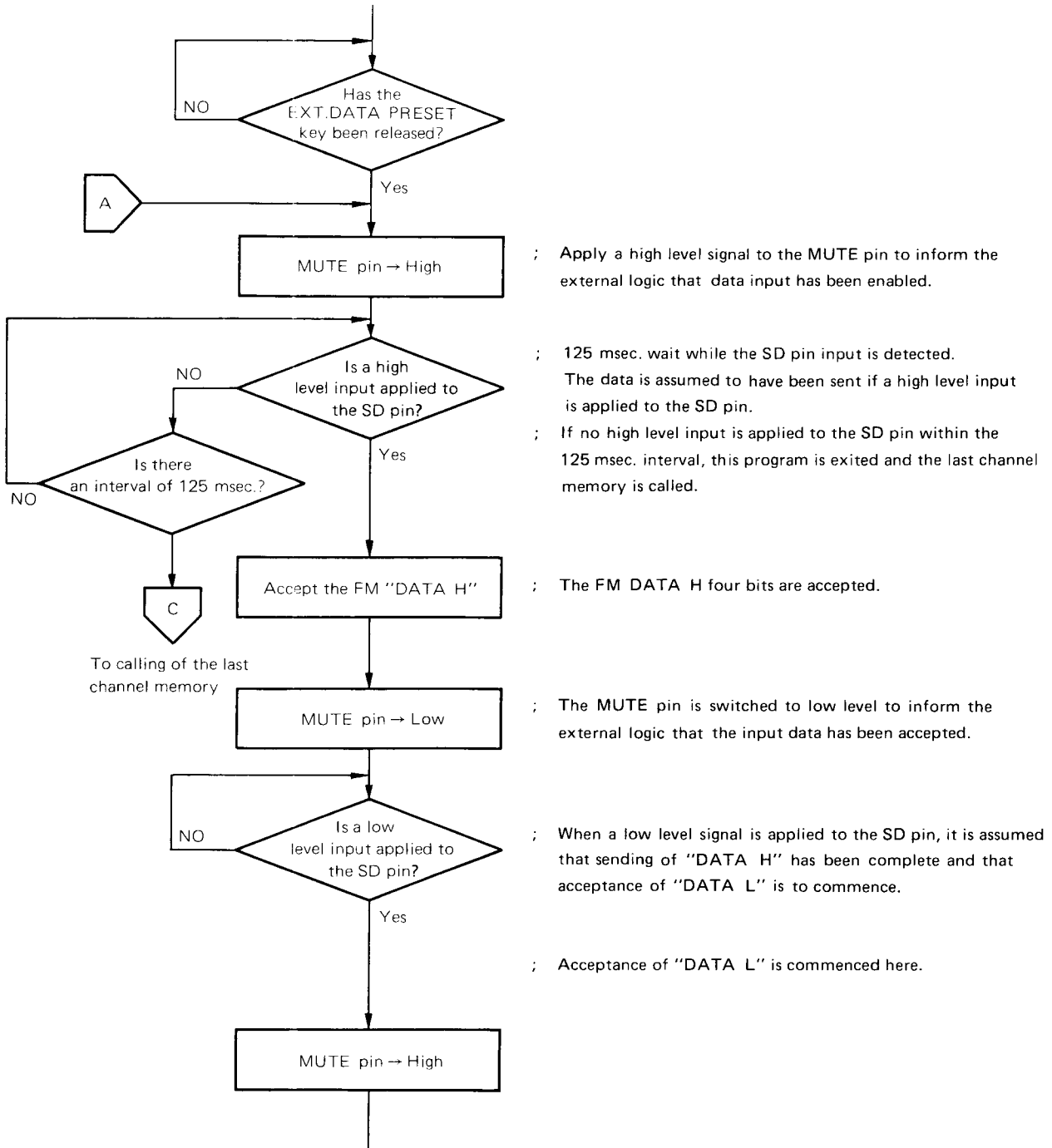

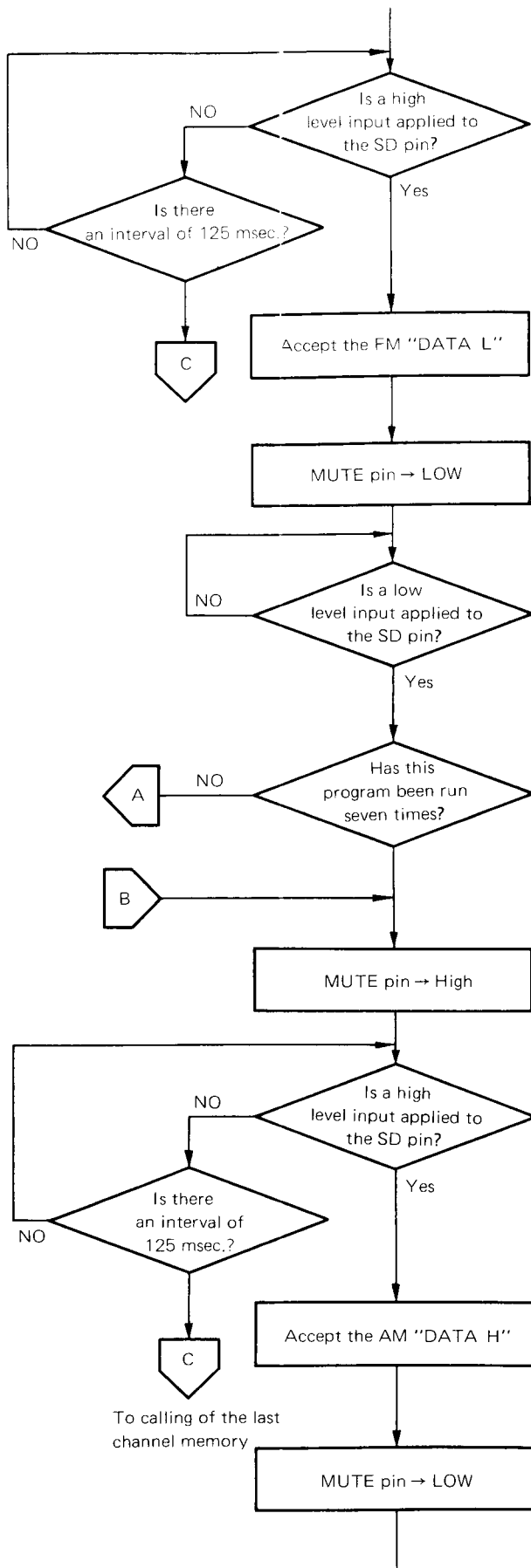

; The FM DATA L four bits are accepted.

; Completion of data acceptance for one FM station.

; After data has been accepted from the seven FM preset memories M1 to M7, acceptance of AM data is commenced.

; The AM DATA H (four bits) are accepted.

To calling of the last channel memory

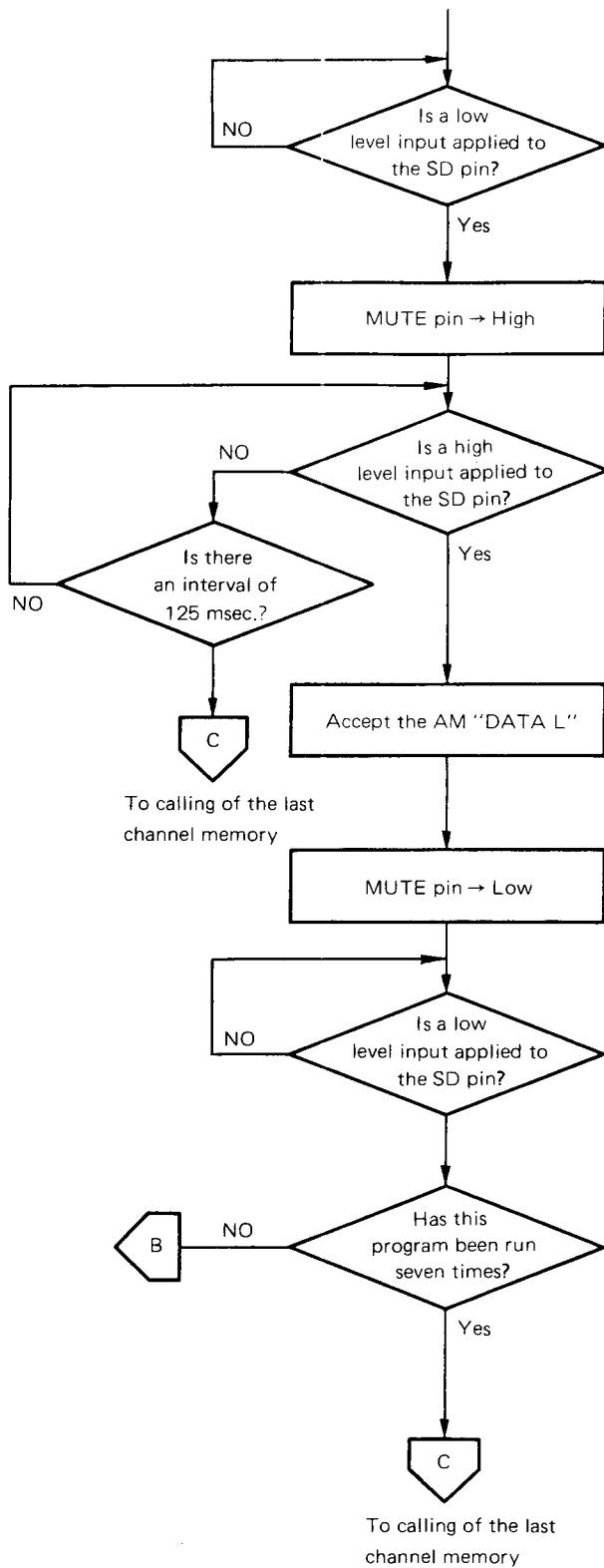

; The AM DATA L (four bits) are accepted.

; After data has been accepted from the seven AM preset memories M1 to M7, this program is exited, and the last channel memory is called to complete the EXT.DATA PRESET process.

Fig. 1 EXT.DATA PRESET Process Flow Chart

Table 1 EXT.DATA PRESET Frequency Data (Channel Nos.)

| DATA H | DATA L | U.S.A. FM | Japanese FM | U.S.A. AM | Japanese AM |
|--------|--------|-----------|-------------|-----------|-------------|
| 0 | 0 | 87.9 MHz | 76.0 MHz | 530 MHz | 531 MHz |
| 0 | 1 | 88.1 | 76.1 | 540 | 540 |
| 0 | 2 | 88.3 | 76.2 | 550 | 549 |
| 0 | 3 | 88.5 | 76.3 | 560 | 558 |
| 0 | 4 | 88.7 | 76.4 | 570 | 567 |
| 0 | 5 | 88.9 | 76.5 | 580 | 576 |
| 0 | 6 | 89.1 | 76.6 | 590 | 585 |
| 0 | 7 | 89.3 | 76.7 | 600 | 594 |
| 0 | 9 | 89.5 | 76.8 | 610 | 603 |
| 0 | A | 89.7 | 76.9 | 620 | 612 |
| 0 | B | 89.9 | 77.0 | 630 | 621 |
| 0 | C | 90.1 | 77.1 | 640 | 630 |
| 0 | D | 90.3 | 77.2 | 650 | 639 |
| 0 | E | 90.5 | 77.3 | 660 | 648 |
| 0 | F | 90.7 | 77.4 | 670 | 657 |
| 1 | 0 | 90.9 | 77.5 | 680 | 666 |
| 1 | 1 | 91.1 | 77.6 | 690 | 675 |
| 1 | 2 | 91.3 | 77.8 | 700 | 684 |
| 1 | 3 | 91.5 | 77.9 | 710 | 693 |
| | | | 78.0 | 720 | 702 |
| 6 | 2 | 107.5 | | | |
| 6 | 3 | 107.7 | 85.9 | 1520 | 1422 |
| 6 | 4 | 107.9 | 86.0 | 1530 | 1431 |
| 6 | 5 | 107.9 | 86.1 | 1540 | 1440 |
| 6 | 6 | 107.9 | 86.2 | 1550 | 1449 |
| 6 | 7 | 107.9 | 86.3 | 1560 | 1458 |
| 6 | 8 | 107.9 | 86.4 | 1570 | 1467 |
| | | | 86.5 | 1580 | 1476 |
| 8 | 4 | 107.9 | 89.2 | | |
| 8 | 5 | 107.9 | 89.3 | 1620 | 1611 |
| 8 | 6 | 107.9 | 89.4 | 1620 | 1611 |
| 8 | 7 | 107.9 | 89.5 | 1620 | 1611 |
| 8 | 8 | 107.9 | 89.6 | 1620 | 1611 |
| 8 | 9 | 107.9 | 89.7 | 1620 | 1611 |
| 8 | A | 107.9 | 89.8 | 1620 | 1611 |
| 8 | B | 107.9 | 89.9 | 1620 | 1611 |
| 8 | C | 107.9 | 90.0 | 1620 | 1611 |

NOTE: DATA H and DATA L denote hexadecimal codes.

4. DESCRIPTION OF THE DISPLAY

4.1 Dynamic Display

The display connections for a dynamic display (with the STATIC/DYNA switch OFF) are shown in the following diagram. \overline{D}_1 to \overline{D}_5 and S_e to S_g correspond to the μ PD1703C-014 digit pins (\overline{D}_1 to \overline{D}_5) and segment pins (S_a to S_g). Since the μ PD1703C-014 segment pins have a voltage endurance of 30 V (Pch open drain output), direct connection to the FIP (fluorescent indicator panel) is possible. The digit pins, however, require a buffer stage (PNP transistor: 2SA733 etc.) since the output signals are both complementary and active low.

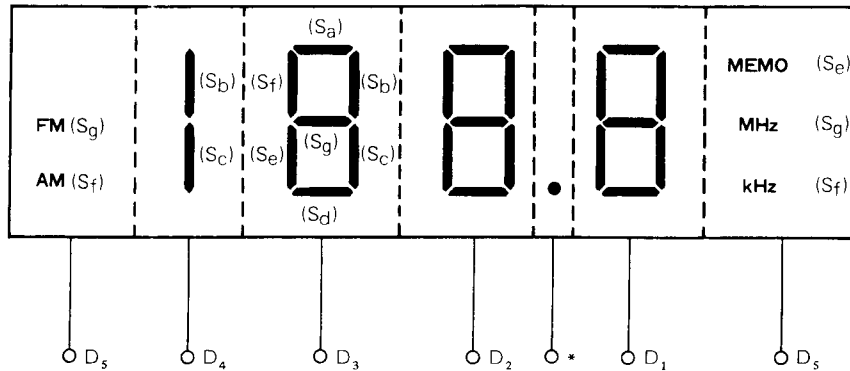

Fig. 2 Dynamic Display Connections Diagram

- * The μ PD1703C-014 does not provide a signal for driving this digit and segment (decimal point). Since the segment is normally required only during FM reception, this digit may be connected to \overline{D}_5 for the decimal point display to be coupled to the FM display.

Examples of displays using the above fluorescent indicator panel.

(1) FM (U.S.A.)

FM 103.7 MHz

(2) AM (U.S.A.)

AM 1620 MEMO* kHz

(3) AM (Japan)

AM 531 kHz

(4) FM (Japan)

FM 76.1 MHz

* The **MEMO** indicator comes on for five seconds after the **MEMORY** momentary key is pressed to write a new frequency into memory.

If one of the preset keys M1 to M7 is pressed during that five second period, the new frequency is stored in memory, and the **MEMO** indicator goes off immediately.

4.2 Static Display

When the STATIC/DYNA key is switched on, the DATA output signal is obtained from the segment S_C pin, the CLOCK output signal is obtained from the digit \overline{D}_1 pin, and the LOAD signal is obtained from the \overline{D}_2 pin. The DATA signal output is obtained serially one bit at a time in the sequence indicated in Table 2.

Table 2 DATA Signal Output Ranking and Display Contents

| Output ranking | 1 | 2 | 3 | 4 | 5 | 6 | 7 | 8 | 9 | 10 | 11 | 12 | 13 | 14 | 15 | 16 | 17 | 18 | 19 | 20 | 21 | 22 | 23 | 24 |
|------------------|----|----|---|---|-----|----|----|---|----------------|----|----|----|--------------|----|----|----|---------------|----|----|----|----------------------------------|----|----|----|
| Display contents | -- | LW | 5 | 0 | MEM | MW | FM | | BCD 100 kHz | | | | BCD 1 MHz | | | | BCD 10 MHz | | | | BCD preset station display | | | |
| | | | | | | | | | 0 | 1 | 2 | 3 | 0 | 1 | 2 | 4 | 0 | 1 | 2 | 4 | 0 | 1 | 2 | 4 |

CLOCK output signals are generated for each bit of DATA signal, resulting in the data being shifted one bit at a time. After the BCD (Binary Coded Decimal) data for the preset station display has been shifted, the LOAD signal is generated to complete the static conversion. The corresponding timing is outlined in Figure 3. The CLOCK and LOAD signals represent active high signals passed from the respective \overline{D}_1 and \overline{D}_2 pins via an inverter.

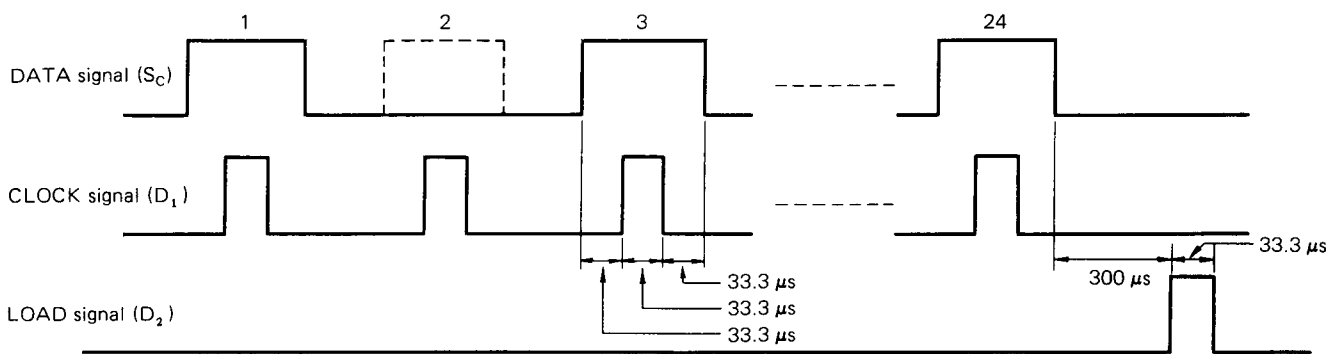

Fig. 3 Timing Chart

These pulse outputs are generated when a switch which changes the display contents is pressed, and at five second intervals after that.

Examples of static display outputs are given below. (In these examples, 1 denotes a high level output and 0 denotes a low level output.)

Example 1. FM 104.3 MHz

| Output ranking | 1 | 2 | 3 | 4 | 5 | 6 | 7 | 8 | 9 | 10 | 11 | 12 | 13 | 14 | 15 | 16 | 17 | 18 | 19 | 20 | 21 | 22 | 23 | 24 | | | | |
|------------------|----|----|---|---|-----|----|----|---|----------------|----|----|----|--------------|----|----|----|---------------|----|----|----|----------------------------------|----|----|----|--------|--|--|--|
| Display contents | -- | LW | 5 | 0 | MEM | MW | FM | | BCD 100 kHz | | | | BCD 1 MHz | | | | BCD 10 MHz | | | | BCD preset station display | | | | | | | |
| Output level | 0 | 0 | 0 | 0 | 0 | 0 | 1 | 1 | 1 | 1 | 0 | 0 | 0 | 0 | 1 | 0 | 0 | 0 | 0 | 0 | 0 | 1 | 0 | 0 | | | | |
| | | | | | | | | | 1 | | | | 3 | | | | 4 | | | | 0 | | | | 2 (M2) | | | |

Example 2. FM 76.0 MHz

| Output ranking | 1 | 2 | 3 | 4 | 5 | 6 | 7 | 8 | 9 | 10 | 11 | 12 | 13 | 14 | 15 | 16 | 17 | 18 | 19 | 20 | 21 | 22 | 23 | 24 |
|------------------|----|----|---|---|-----|----|----|---|----------------|----|----|----|--------------|----|----|---------------|----|----|------------------|----------------------------------|----|----|----|----|
| Display contents | -- | LW | 5 | 0 | MEM | MW | FM | | BCD 100 kHz | | | | BCD 1 kHz | | | BCD 10 MHz | | | | BCD preset station display | | | | |
| Output level | 0 | 0 | 0 | 0 | 0 | 0 | 1 | 0 | 0 | 0 | 0 | 0 | 0 | 1 | 1 | 0 | 1 | 1 | 1 | 0 | 0 | 0 | 0 | 0 |
| | FM | | | | | | | 0 | | | | 6 | | | 7 | | | | 0 (Last channel) | | | | | |

Example 3. AM 1 422 kHz

| Output ranking | 1 | 2 | 3 | 4 | 5 | 6 | 7 | 8 | 9 | 10 | 11 | 12 | 13 | 14 | 15 | 16 | 17 | 18 | 19 | 20 | 21 | 22 | 23 | 24 |
|------------------|----|----|---|---|-----|----|----|---|--------------|----|----|----|---------------|----|----|----------------|----|--------|----|----------------------------------|----|----|----|----|
| Display contents | -- | LW | 5 | 0 | MEM | MW | FM | | BCD 1 kHz | | | | BCD 10 kHz | | | BCD 100 kHz | | | | BCD Preset station display | | | | |
| Output level | 0 | 0 | 0 | 0 | 0 | 1 | 0 | 1 | 0 | 1 | 0 | 0 | 0 | 1 | 0 | 0 | 0 | 0 | 1 | 0 | 1 | 1 | 1 | 0 |
| | AM | | | | | | | 1 | 2 | | 2 | | | 4 | | | | 7 (M7) | | | | | | |

Example 4. AM 810 kHz

| Output ranking | 1 | 2 | 3 | 4 | 5 | 6 | 7 | 8 | 9 | 10 | 11 | 12 | 13 | 14 | 15 | 16 | 17 | 18 | 19 | 20 | 21 | 22 | 23 | 24 |
|------------------|----|----|---|---|-----|----|----|---|--------------|----|----|----|---------------|----|----|----------------|----|----|--------|----------------------------------|----|----|----|----|
| Display contents | -- | LW | 5 | 0 | MEM | MW | FM | | BCD 1 kHz | | | | BCD 10 kHz | | | BCD 100 kHz | | | | BCD Preset station display | | | | |
| Output level | 0 | 0 | 0 | 0 | 0 | 1 | 0 | 0 | 0 | 0 | 0 | 0 | 1 | 0 | 0 | 0 | 0 | 0 | 0 | 1 | 1 | 1 | 0 | 0 |
| | AM | | | | | | | 0 | | | | 1 | | | 8 | | | | 3 (M3) | | | | | |

5. PRESET STATION DISPLAY*

An example of preset station display connections is given in Figure 4.

A BCD (Binary Coded Decimal) code output is obtained from the segment pins S_a to S_c during the timing of the \overline{D}_5 digit signal. The relevant timing chart is shown in Figure 5.

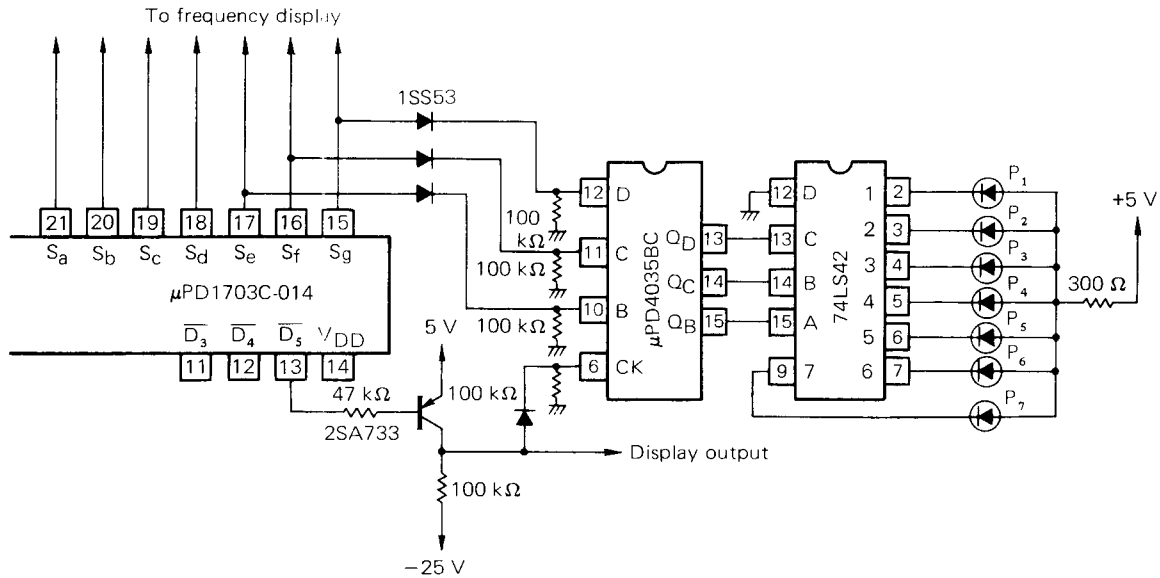

Fig. 4 Preset Station Display Connection Example

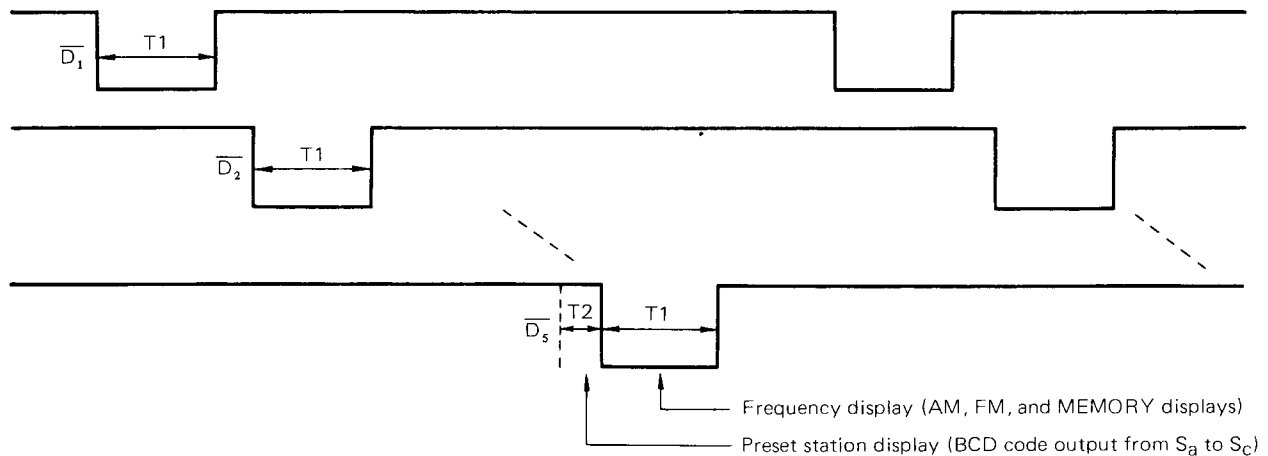

Fig. 5 Timing Chart

The "AM, FM, and MEMO" display signal outputs are obtained from the S_e , S_f , and S_g segment pins during the T_1 timing of the \overline{D}_5 digit signal. (The output on the S_a to S_c segment pins at this time is a "blank code" output.) And the BCD output code for preset station display is obtained from the S_a to S_c pins during the T_2 timing (the output on the S_e to S_g pins at this time being a "blank code" output).

* "Preset station display" refers to one of the dot display elements (P1 to P7 corresponding to one of the preset keys M1 to M7) which comes on when that key is pressed (for frequency store or call purposes).

The dynamic output indicated in the Figure 5 timing chart must be changed to a static output. (If display elements requiring a large current, such as LEDs, are used in the preset station display, noise generated by the dynamic display may be picked up by the receiver antenna, RF stage, or IF stage.)

The μ PD4035BC device is a static converter D-F/F. Since the outputs from the μ PD1703C-014 digit pins are active low, data is latched by μ PD4035BC at the rising edge of the \overline{D}_5 active high digit signal passed via an inverter stage.

Output status of the S_a to S_g segment pins during the T1 and

T2 Timing of the \overline{D}_5 Digit Signal

| Segment Timing | S_a | S_b | S_c | S_d | S_e | S_f | S_g |
|-------------------|-----------------|-------|-------|-------|------------------------|-------|-------|
| T1 | Blank | Blank | Blank | Blank | "FM, AM, MEMO" display | | |
| T2 | BCD code output | | | Blank | Blank | Blank | Blank |

Preset Station BCD Code Outputs

| S_a | S_b | S_c | Preset station |
|-------|-------|-------|----------------|
| 0 | 0 | 1 | P1 (M1 key) |
| 0 | 1 | 0 | P2 (M2 key) |
| 0 | 1 | 1 | P3 (M3 key) |
| 1 | 0 | 0 | P4 (M4 key) |
| 1 | 0 | 1 | P5 (M5 key) |
| 1 | 1 | 0 | P6 (M6 key) |
| 1 | 1 | 1 | P7 (M7 key) |

6. TIMING CHARTS

6.1 Display and Key Input Acceptance

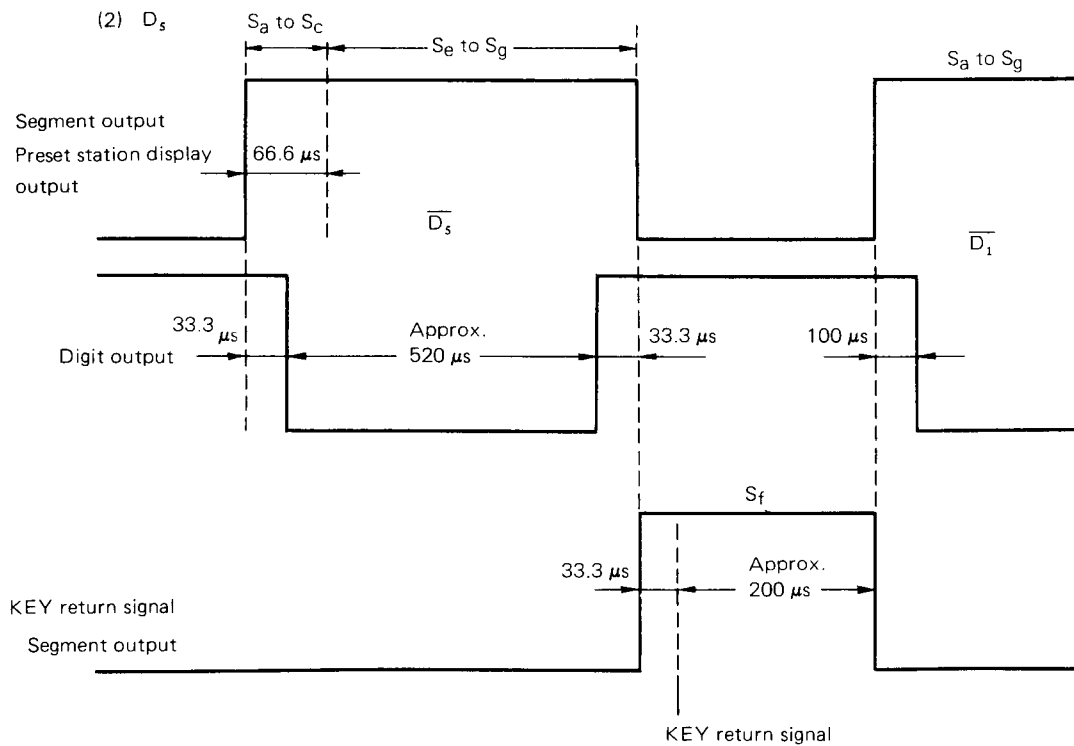
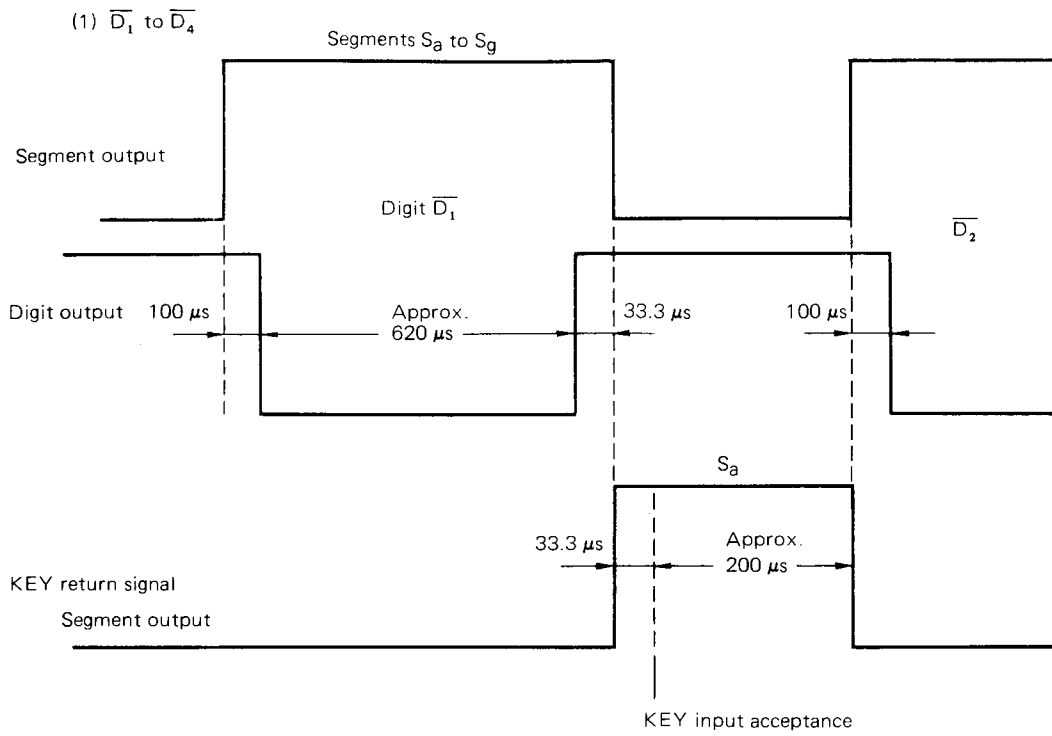

Duty:

10.7 % (\overline{D}_1 to \overline{D}_4)

8.9 % (\overline{D}_3)

6.2 MUTE Timing Charts

- ① KEY ON chattering suppression time
- ② MUTE "first out" time
- ③ Time taken to set frequency division ratio and change display contents
- ④ MUTE "last out" time
- ⑤ Scanning time
- ⑥ PLL lock time

(1) MANUAL UP/DOWN

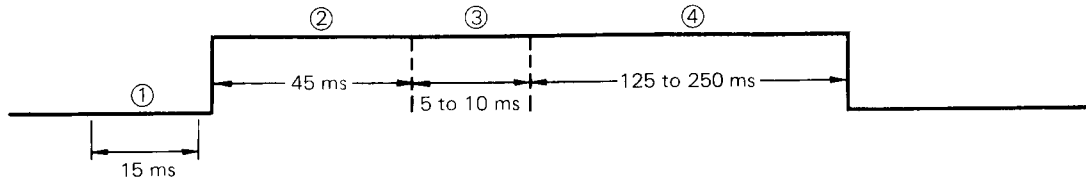

(2) AUTO UP/DOWN

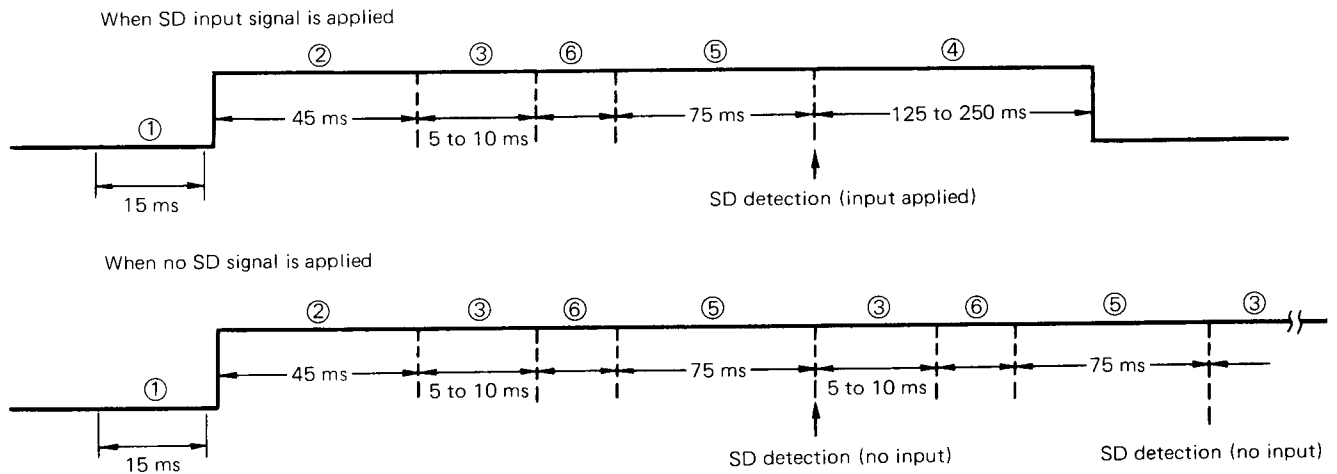

(3) PRESET MEMORY CALL

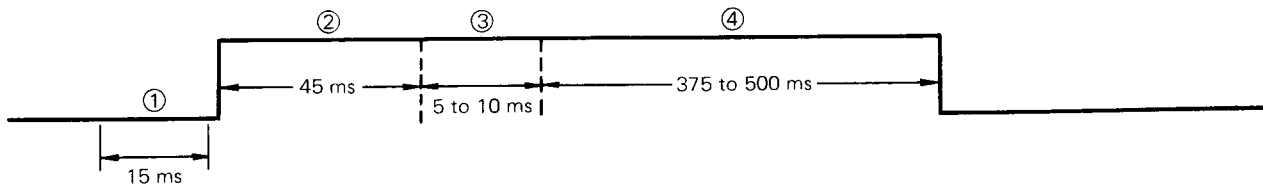

(4) FM/AM selection and when power is switched on (CE = Low → High)

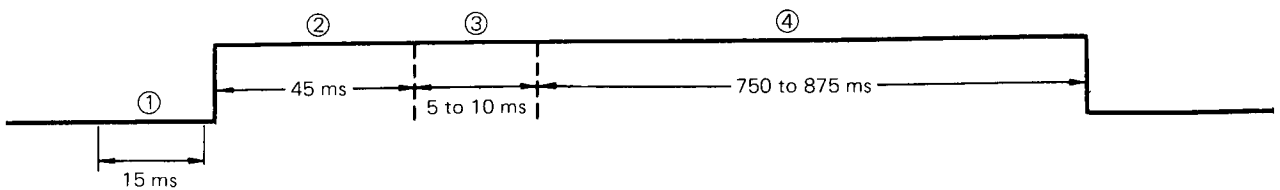

7. APPRICATION CIRCUIT

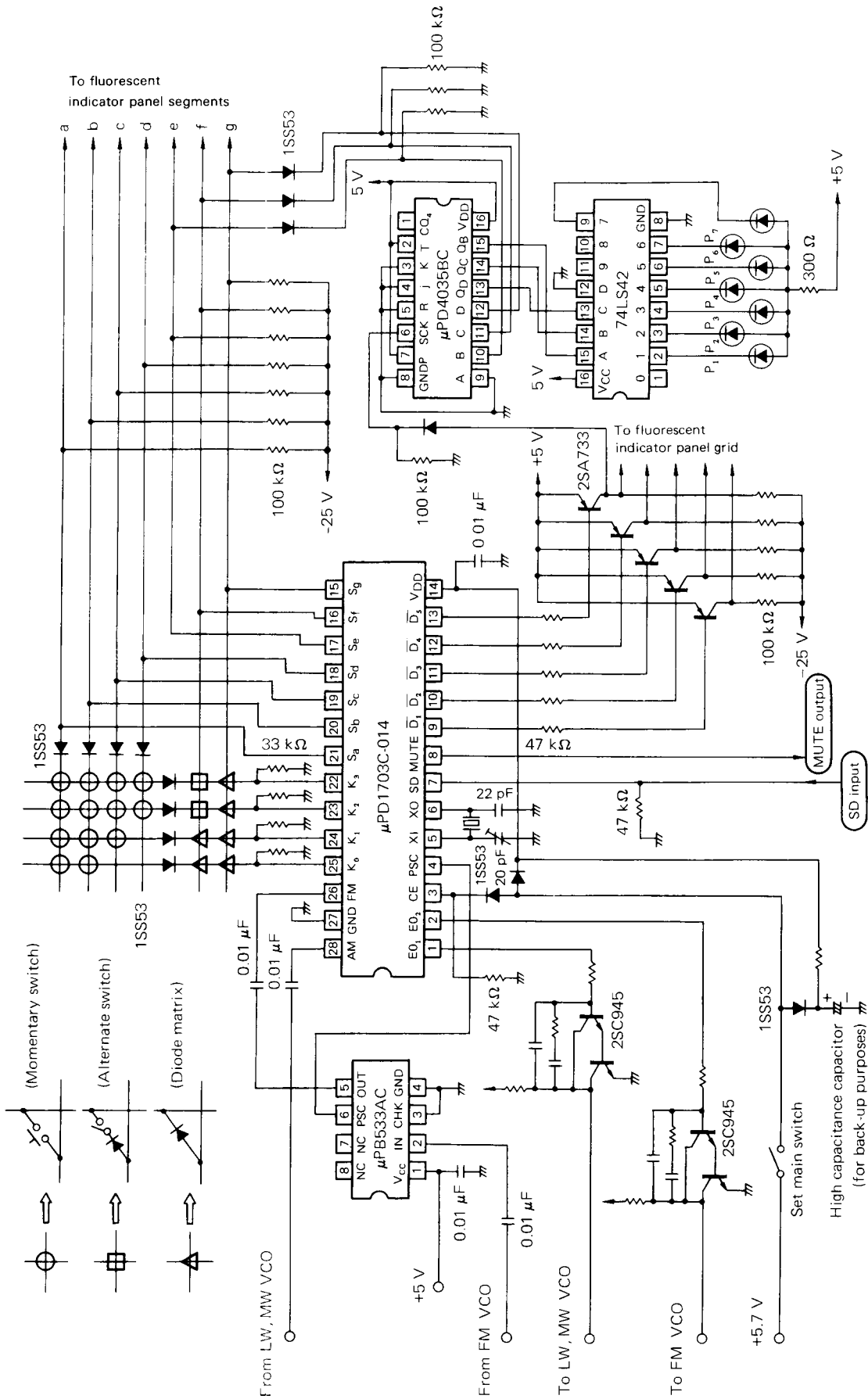

The practical circuits and circuit constants shown in this manual have not been designed for mass production (where deviation between parts and temperature characteristics must also be considered). Also note that NEC bears no responsibility in respect to patents related to these circuits.

8. ELECTRICAL CHARACTERISTICS

8.1 ABSOLUTE MAXIMUM RATINGS

| | | | |
|--------------------------|-----------|---|-------|
| Power supply voltage | V_{DD} | -0.3 to +6.0 | V |
| Input voltage | V_I | -0.3 to $+V_{DD}$ | V |
| Output voltage | V_O | -0.3 to $+V_{DD}$ | V |
| Output current | I_O | 10 | mA |
| Operating temperature | T_{opt} | -35 to +75 | °C |
| Storage Temperature | T_{stg} | -55 to +125 | °C |
| Output voltage endurance | V_{BDS} | Between S_a and S_g pins (drain - source voltage) | -35 V |

8.2 RECOMMENDED OPERATING CONDITIONS

| CHARACTERISTIC | SYMBOL | MIN. | TYP. | MAX. | UNIT | CONDITION |
|--------------------------------|------------|------|------|------|------|--|
| Power supply voltage | V_{DD} | 4.5 | 5.0 | 5.5 | V | |
| RAM hold voltage | V_{RAM} | 2.5 | | | V | CE pin = 0 |
| Output voltage endurance | V_{BDS} | | | -30 | V | S_a to S_g pins (drain-source voltage), $I_{OFF} = -5 \mu A$ |
| Power supply voltage rise time | T_{rise} | | | 500 | ms | $V_{DD} = 0 \rightarrow 4.5 V$ |

8.3 DC CHARACTERISTICS ($V_{DD} = +4.5 \sim +5.5 V$, $T_a = -35 \sim +75 \text{ }^\circ\text{C}$)

| CHARACTERISTIC | SYMBOL | MIN. | TYP. | MAX. | UNIT | CONDITION |
|---------------------------|------------|-------------|-----------|-------------|-----------|---|
| High level input voltage | V_{IH1} | $0.8V_{DD}$ | | V_{DD} | V | SD pin |
| High level input voltage | V_{IH2} | $0.7V_{DD}$ | | V_{DD} | V | CE pin |
| High level input voltage | V_{IH3} | $0.6V_{DD}$ | | V_{DD} | V | K_0 to K_3 pins |
| Low level input voltage | V_{IL1} | 0 | | $0.3V_{DD}$ | V | CE pin |
| Low level input voltage | V_{IL2} | 0 | | $0.2V_{DD}$ | V | SD, K_0 to K_3 pins |
| High level output voltage | V_{OH1} | 4.0 | | | V | PSC, MUTE, \overline{D}_1 to \overline{D}_5 pins $I_{OH} = -0.2 \text{ mA}$ |
| High level output voltage | V_{OH2} | 4.0 | | | V | EO_1 , EO_2 pins $I_{OH} = -0.5 \text{ mA}$ |
| High level output voltage | V_{OH3} | 3.0 | | | V | S_a to S_g pins $I_{OH} = -0.5 \text{ mA}$ |
| Low level output voltage | V_{OL1} | | | 0.5 | V | EO_1 , EO_2 pins $I_{OL} = 0.5 \text{ mA}$ |
| Low level output voltage | V_{OL2} | | | 0.5 | V | MUTE, \overline{D}_1 to \overline{D}_5 , PSC pins $I_{OL} = 0.2 \text{ mA}$ |
| High level input current | $+I_{IH1}$ | 5.0 | 25 | 100 | μA | K_0 to K_3 pins $V_{IN} = V_{DD} = 5.0 V$ |
| High level input current | $+I_{IH2}$ | | 300 | | μA | XI pin $V_{IN} = V_{DD} = 5.0 V$ |
| Low level input current | $-I_{IL1}$ | | 300 | | μA | AM, FM pins $V_{IN} = 0 V$, $V_{DD} = 5.0 V$ |
| Output leak current | I_L | | 10^{-3} | 1 | μA | EO_1 , EO_2 pins $V_O = V_{DD} = 5.0 V$ |
| AC input voltage | V_{tn} | 1.0 | | V_{DD} | V_{p-p} | AM, FM pins |
| Operating current | I_{DD1} | | 3 | | mA | Normal operation (except display current) |
| Operating current | I_{DD2} | | | 10 | μA | CE pin = 0 $T_a = 25 \text{ }^\circ\text{C}$, $V_{DD} = 5 V$ |
| RAM hold voltage | V_{RAM} | 2.5 | | | V | CE pin = 0 |
| Output voltage endurance | V_{BDS} | | | -30 | V | S_a to S_g pins (drain - source voltage), $I_{OFF} = -5 \mu A$ |

8.4 AC CHARACTERISTICS ($V_{DD} = +4.5$ to $+5.5$ V, $T_a = -35$ to $+75$ °C)

| CHARACTERISTIC | SYMBOL | MIN. | TYP. | MAX. | UNIT | CONDITION |
|---------------------|----------|------|------|------|------|--|
| Operating frequency | f_{AM} | 0.5 | | 2.5 | MHz | AM pin, $V_{in} = 1.0 V_{p-p}$ (MIN.), DC cut |
| Operating frequency | f_{FM} | 0.5 | | 8.8 | MHz | FM pin, $V_{in} = 0.8 V_{p-p}$ (MIN.), square wave, DC cut |

9. PACKAGE DIMENSIONS (UNIT: mm)

28-pin Plastic DIP (400 mil)

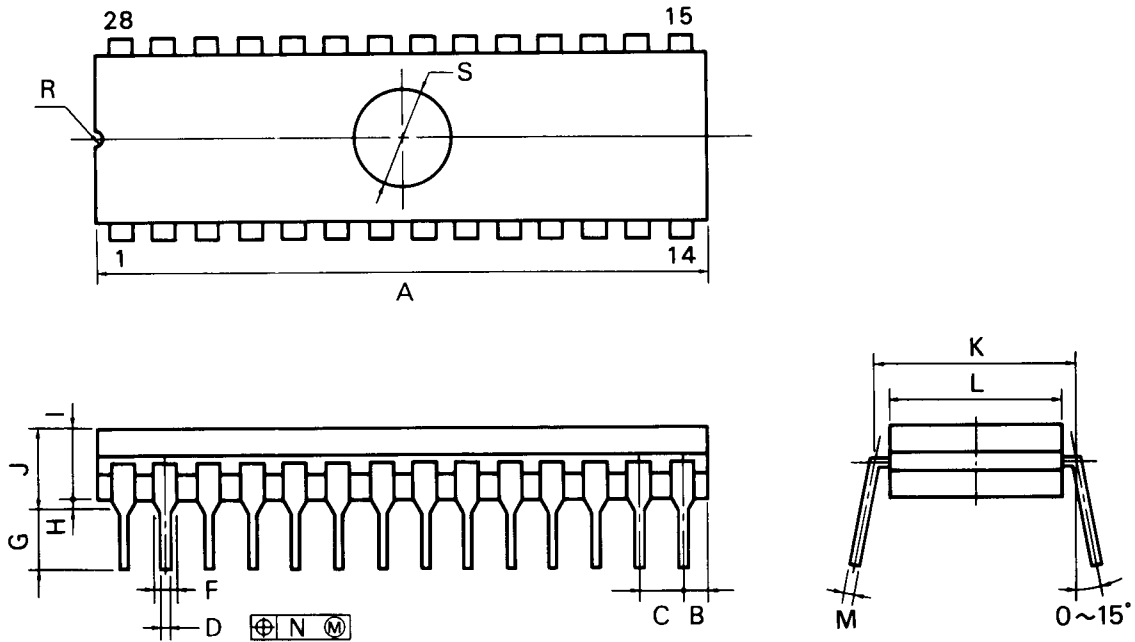

P28C-100-400

NOTES

- 1) Each lead centerline is located within 0.25 mm (0.01 inch) of its true position (T.P.) at maximum material condition.
- 2) Item "K" to center of leads when formed parallel.

| ITEM | MILLIMETERS | INCHES |
|------|-----------------|----------------------------|
| A | 38.10 MAX. | 1.500 MAX. |
| B | 2.54 MAX. | 0.100 MAX. |
| C | 2.54 (T.P.) | 0.100 (T.P.) |
| D | 0.50 ± 0.10 | 0.020 $^{+0.004}_{-0.005}$ |
| F | 1.2 MIN. | 0.047 MIN. |
| G | 3.5 ± 0.3 | 0.138 ± 0.012 |
| H | 0.51 MIN. | 0.020 MIN. |
| I | 3.80 | 0.150 |
| J | 5.08 MAX. | 0.200 MAX. |
| K | 15.24 (T.P.) | 0.600 (T.P.) |
| L | 13.21 | 0.520 |
| M | 0.25 ± 0.05 | 0.010 $^{+0.002}_{-0.003}$ |
| N | 0.25 | 0.01 |
| R | R 0.65 | R 0.026 |
| S | ϕ 7.62 | ϕ 0.300 |