

MB15A02 ASSP

SERIAL INPUT PLL FREQUENCY SYNTHESIZER

LOW POWER SERIAL INPUT PLL SYNTHESIZER WITH 1.1GHZ PRESCALER

The Fujitsu MB15A02, utilizing Bi-CMOS technology, is a single chip serial input PLL synthesizer with pulse-swallow function.

The MB15A02 contains a 1.1GHz two modulus prescaler that can select either a 64/65 or 128/129 divide ratio, control signal generator, 16-bit shift register, 15-bit latch, programmable reference divider (binary 14-bit programmable reference counter), 1-bit switch counter, phase comparator with phase reverse function, charge pump, crystal oscillator, 19-bit shift register, 18-bit latch, and programmable divider (binary 7-bit swallow counter and binary 11-bit programmable counter).

It operates supply voltage of 5V typ. and achieves very low supply current of 7mA typ. realized through the use of Fujitsu Advanced Process Technology.

- High operating frequency: $f_{IN\ MAX}=1.1GHz$ ($P_{IN\ MIN}=-10dBm$)
- Pulse swallow function: 64/65 or 128/129
- Low supply current: $I_{CC}=7mA$ typ.
- Serial input 18-bit programmable divider consisting of:
 - Binary 7-bit swallow counter: 0 to 127
 - Binary 11-bit programmable counter: 16 to 2,047
- Serial input 15-bit programmable reference divider consisting of:
 - Binary 14-bit programmable reference counter: 6 to 16,383
 - 1-bit switch counter (SW) sets divide ratio of prescaler
- Two types of phase detector output
 - On-chip charge pump (Bipolar type)
 - Output for external charge pump
- Wide operating temperature: $-40^{\circ}C$ to $+85^{\circ}C$
- 16-pin Plastic SOP Package
16-pin and 20-pin Plastic SSOP Packages

ABSOLUTE MAXIMUM RATINGS (See NOTE)

Rating	Symbol	Rating	Unit	Remark
Power Supply Voltage	V_{CC}	-0.5 to +7.0	V	
	V_P	V_{CC} to 8.0	V	
Output Voltage	V_{OUT}	-0.5 to $V_{CC} + 0.5$	V	$\emptyset P$ pin
Open-drain Voltage	V_{OOP}	-0.5 to 6.0	V	
Output Current	I_{OUT}	± 10	mA	
Storage Temperature	T_{STG}	-55 to +125	$^{\circ}C$	

NOTE: Permanent device damage may occur if the above **Absolute Maximum Ratings** are exceeded. Functional operation should be restricted to the conditions as detailed in the operational sections of this data sheet. Exposure to absolute maximum rating conditions for extended periods may affect device reliability.

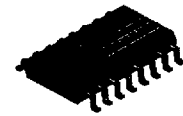

PLASTIC PACKAGE
FPT-16P-M05

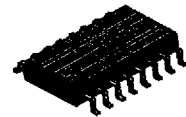

PLASTIC PACKAGE
FPT-16P-M06

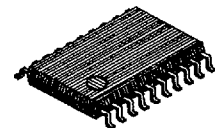

PLASTIC PACKAGE
FPT-20P-M03

This device contains circuitry to protect the inputs against damage due to high static voltages or electric fields. However, it is advised that normal precautions be taken to avoid application of any voltage higher than maximum rated voltages to this high impedance circuit.

PIN ASSIGNMENT

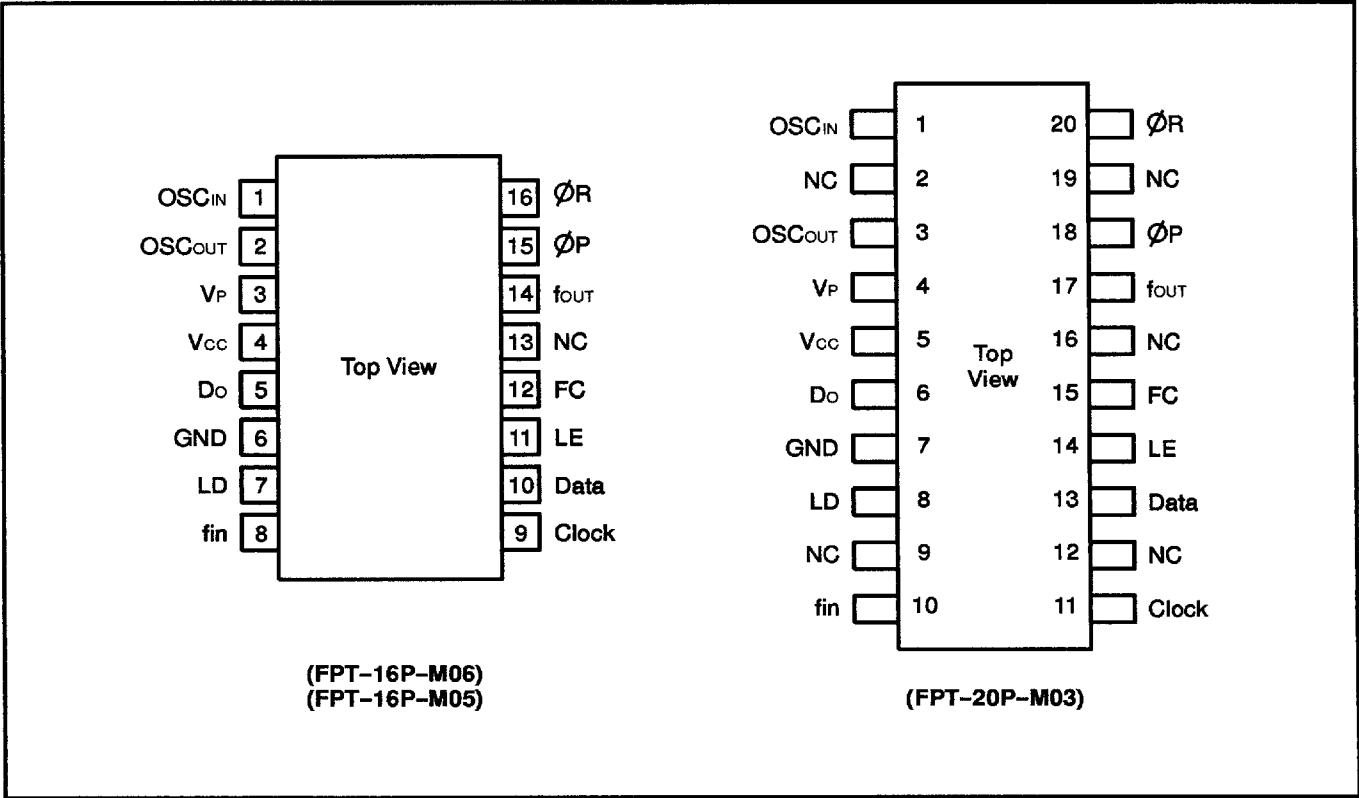

BLOCK DIAGRAM

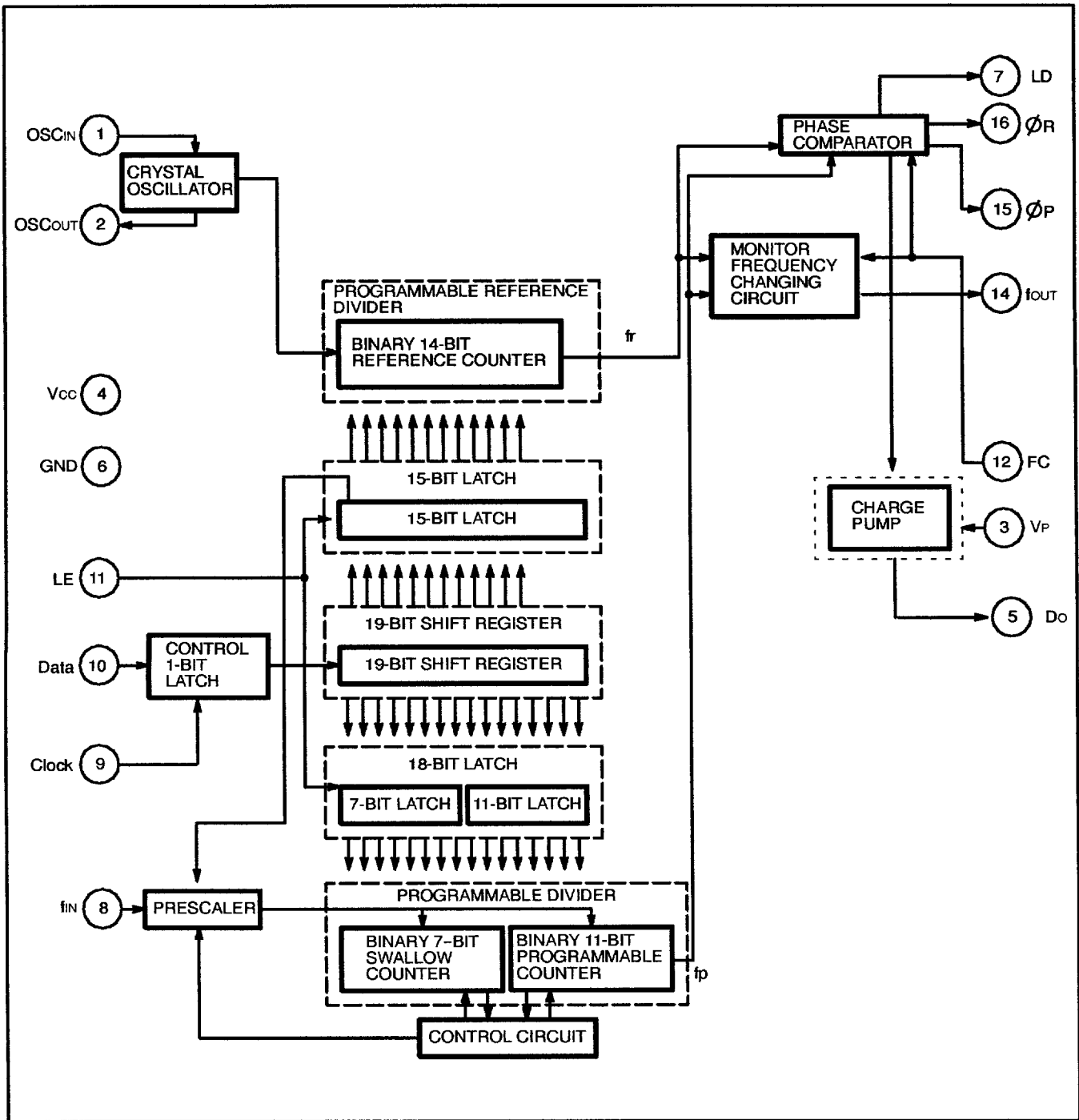

Note : Pin numbers are based on SOP/SSOP 16-pin packages.

3749756 0009437 215

PIN DESCRIPTION

Pin No.		Pin Name	I/O	Description
SOP-16P SSOP-16P	SSOP-20P			
1 2	1 3	OSC _{IN} OSC _{OUT}	I O	Oscillator input. Oscillator output. A crystal is placed between OSC _{IN} and OSC _{OUT} .
3	4	V _P	-	Power supply pin for charge pump. When the internal charge pump is not used, V _P pin needs to be connected to V _{CC} .
4	5	V _{CC}	-	Power supply pin.
5	6	D _O	O	Charge pump output.
6	7	GND	-	Ground.
7	8	LD	O	Phase comparator output. Normally this pin outputs high level. When there is a phase error between fr and fp, LD becomes low for the period corresponding to the error.
8	10	f _{IN}	I	Prescaler input. The connection with an external VCO should be AC connection.
9	11	Clock	I	Clock input for 19-bit shift register and 16-bit shift register. On rising edge of the clock shifts one bit of data into shift register.
10	13	Data	I	Binary serial data input. The last bit of data is a control bit. When this bit is high level, the data stored in shift register is transferred to 15-bit latch. When this bit is low level and LE is high level, the data is transferred to 18-bit latch.
11	14	LE	I	Load enable input (with internal pull up resistor). When LE is high, the data stored in shift register is transferred into latch according to the control bit.
12	15	FC	I	Phase select input of phase comparator (with internal pull up resistor). When FC is low level, the characteristics of phase comparator is reversed. FC input signal is also used to select f _{OUT} pin (test pin) output, fr or fp.
13	2,9,12,16,19	NC	-	No connection
14	17	f _{OUT}	O	Minor pin of phase comparator input. f _{OUT} pin outputs either programmable reference divider output (fr) or programmable divider output (fp) according to FC pin input level. FC=H: It is the same as fr output level. FC=L: It is the same as fp output level.
15	18	∅P	O	Outputs for external charge pump. The characteristics are reversed according to FC input. ∅P pin is N-channel open drain output.
16	20	∅R	O	Outputs for external charge pump. ∅R pin is CMOS output.

FUNCTIONAL DESCRIPTIONS

SERIAL DATA INPUT

Serial data input is achieved by three inputs, such as Data pin, Clock pin and LE pin. Serial data input controls 15-bit programmable reference divider and 18-bit programmable divider, respectively.

Binary serial data is input to Data pin.

On rising edge of clock shifts one bit of serial data into the internal shift register and when load enable pin is high level or open, stored data is transferred into latch according to the control bit.

Control data "H" data is transferred into 15-bit latch.

Control data "L" data is transferred into 18-bit latch.

PROGRAMMABLE REFERENCE DIVIDER

Programmable reference divider consists of 16-bit shift register, 15-bit latch and 14-bit programmable reference counter. Serial 16-bit data format is shown below.

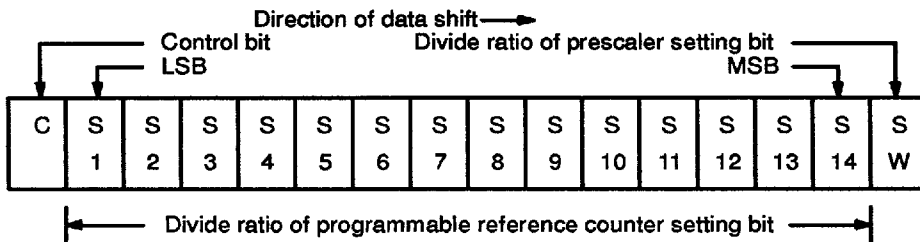

14-BIT PROGRAMMABLE REFERENCE COUNTER DIVIDE RATIO

Divide Ratio R	S 14	S 13	S 12	S 11	S 10	S 9	S 8	S 7	S 6	S 5	S 4	S 3	S 2	S 1
6	0	0	0	0	0	0	0	0	0	0	0	1	1	0
7	0	0	0	0	0	0	0	0	0	0	0	1	1	1
•	•	•	•	•	•	•	•	•	•	•	•	•	•	•
16383	1	1	1	1	1	1	1	1	1	1	1	1	1	1

- NOTES:** Divide ratio less than 6 is prohibited.
 Divide ratio: 6 to 16,383
 SW: This bit selects divide ratio of prescaler.
 SW=H : 64/65
 SW=L : 128/129
 S1 to S14: These bits select divide ratio of programmable reference divider.
 C: Control bit (sets at high level).
 Start data input with MSB first.

PROGRAMMABLE DIVIDER

Programmable divider consists of 19-bit shift register, 18-bit latch, 7-bit swallow counter and 11-bit programmable counter. Serial 19-bit data format is shown following page.

3749756 0009439 098

MB15A02

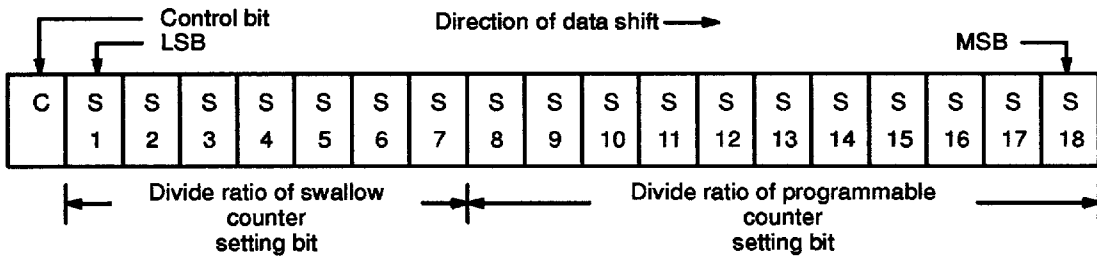

7-BIT SWALLOW COUNTER DIVIDE RATIO

Divide Ratio A	S 7	S 6	S 5	S 4	S 3	S 2	S 1
0	0	0	0	0	0	0	0
1	0	0	0	0	0	0	1
•	•	•	•	•	•	•	•
127	1	1	1	1	1	1	1

NOTE: Divide ratio: 0 to 127

11-BIT PROGRAMMABLE COUNTER DIVIDE RATIO

Divide Ratio N	S 18	S 17	S 16	S 15	S 14	S 13	S 12	S 11	S 10	S 9	S 8
16	0	0	0	0	0	0	1	0	0	0	0
17	0	0	0	0	0	0	1	0	0	0	1
•	•	•	•	•	•	•	•	•	•	•	•
2047	1	1	1	1	1	1	1	1	1	1	1

NOTES: Divide ratio less than 16 is prohibited.
 Divide ratio: 16 to 2,047
 S1 to S7: Swallow counter divide ratio setting bit. (0 to 127)
 S8 to S18: Programmable counter divide ratio setting bit.
 C: Control bit (sets at low level).
 Data input with MSB first.

PULSE SWALLOW FUNCTION

$$f_{VCO} = [(P \times N) + A] \times f_{osc} \div R$$

f_{VCO} : Output frequency of external voltage controlled oscillator (VCO)

N: Preset divide ratio of binary 11-bit programmable counter (16 to 2,047)

A: Preset divide ratio of binary 7-bit swallow counter ($0 \leq A \leq 127$, $A < N$)

f_{osc} : Output frequency of the external reference frequency oscillator

R: Preset divide ratio of binary 14-bit programmable reference counter (6 to 16,383)

P: Preset modulus of external dual modulus prescaler (64 or 128)

Serial data input timing

- t_1 ($\geq 100\text{ns}$) : Data setup time t_2 ($\geq 1000\text{ns}$) : Data hold time t_3 ($\geq 300\text{ns}$) : Clock pulse width
- t_4 ($\geq 100\text{ns}$) : LE setup time to the rising edge of last clock t_5 ($\geq 800\text{ns}$) : LE pulse width

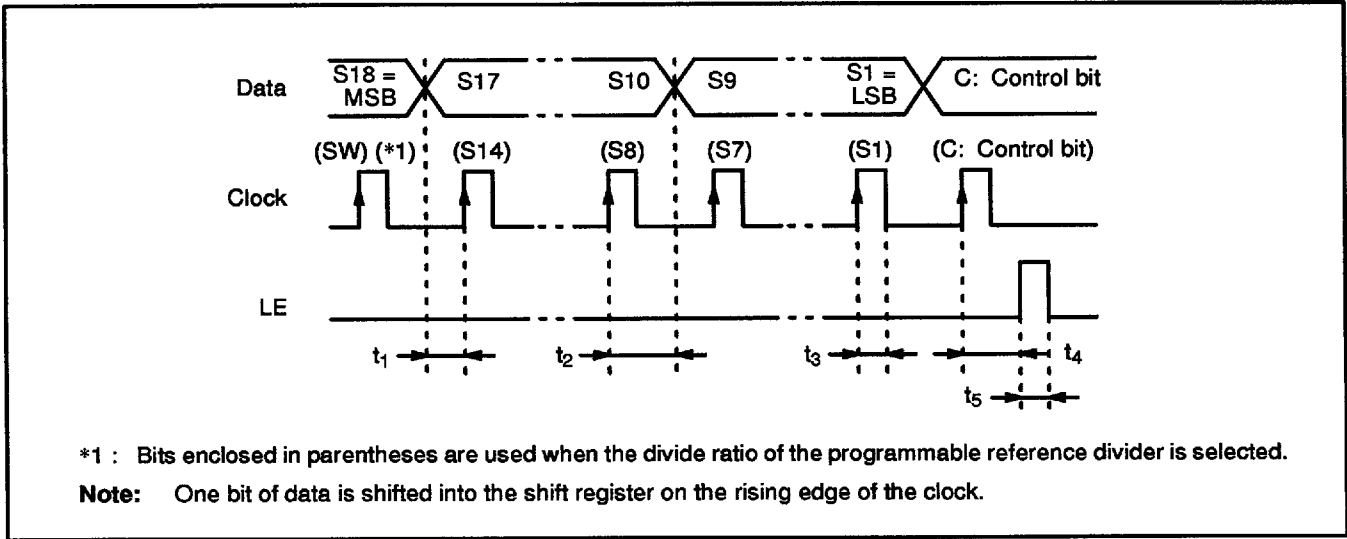

PHASE CHARACTERISTICS

FC pin is provided to change phase characteristics of phase comparator. Characteristics of internal charge pump output level (D_0), phase comparator output level (ϕ_R , ϕ_P) are reversed depending upon FC pin input level. Also, monitor pin (f_{out}) output level of phase comparator is controlled by FC pin input level. The relation between outputs (D_0 , ϕ_R , ϕ_P) and FC input level are shown below.

	FC=H or open				FC=L			
	DO	ϕ_R	ϕ_P	fout	DO	ϕ_R	ϕ_P	fout
$f_r > f_p$	H	L	L	(fr)	L	H	Z	(fp)
$f_r < f_p$	L	H	Z	(fr)	H	L	L	(fp)
$f_r = f_p$	Z	L	Z	(fr)	Z	L	Z	(fp)

Note: Z=(High impedance)

Depending upon VCO characteristics, FC pin should be set accordingly:
 When VCO characteristics are like ①, FC should be set High or open circuit;
 When VCO characteristics are like ②, FC should be set Low.

VCO CHARACTERISTICS

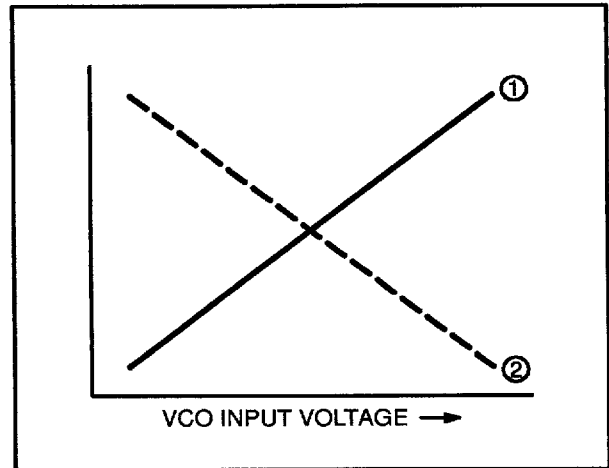

OUTPUT WAVEFORM

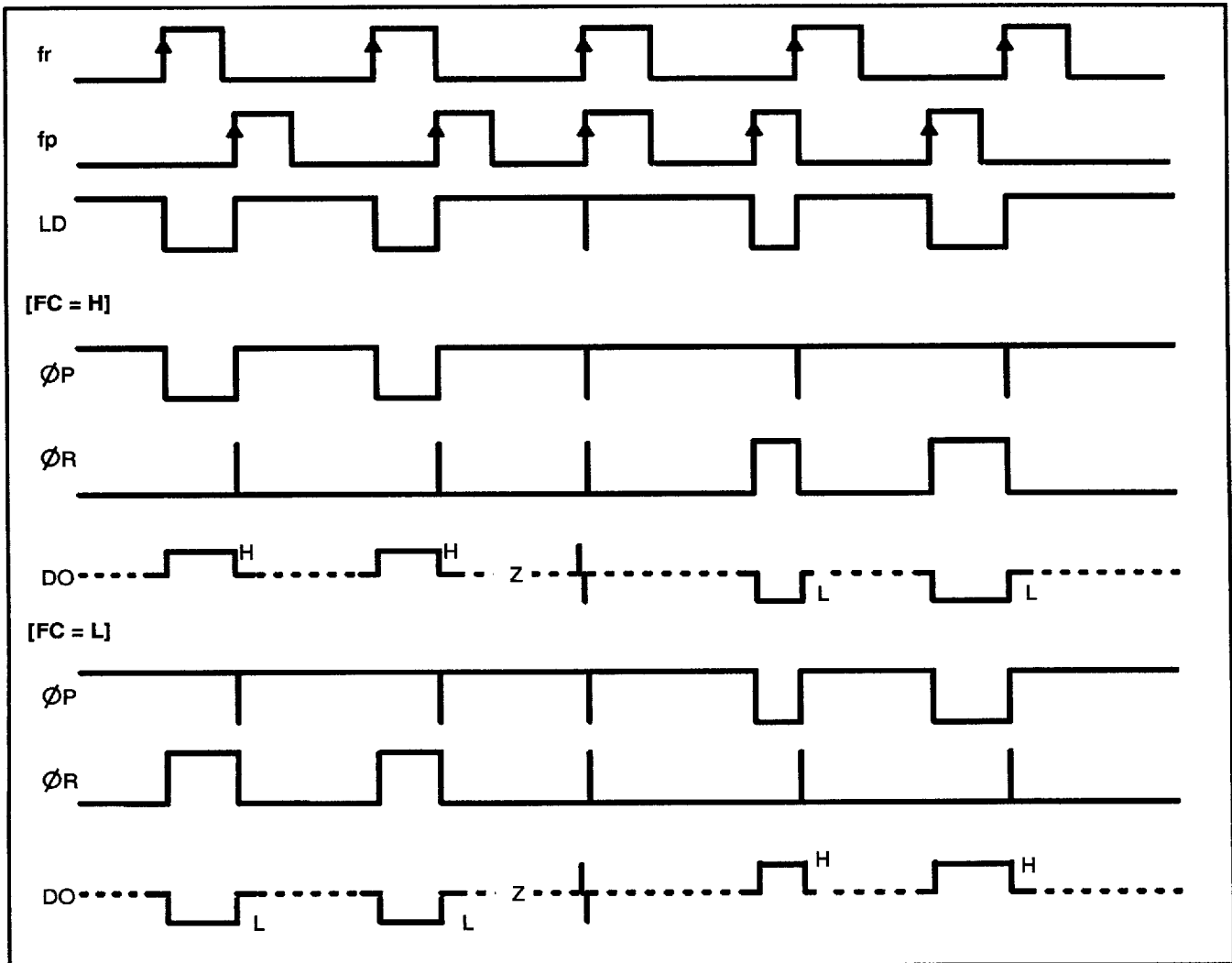

NOTE: Phase error detection range: -2π to $+2\pi$

RECOMMENDED OPERATING CONDITIONS

Parameter	Symbol	Value			Unit
		Min	Typ	Max	
Power Supply Voltage	V _{CC}	4.5	5.0	5.5	V
	V _P	V _{CC}	-	6.0	V
Input Voltage	V _I	GND	-	V _{CC}	V
Operating Temperature	T _a	-40	-	85	°C

ELECTRICAL CHARACTERISTICS

Parameter	Symbol	Value			Unit	Condition	
		Min	Typ	Max			
Power Supply Current	I _{CC}	-	7.0	-	mA	*1	
Operating Frequency	f _{in}	10	-	1100	MHz	*2	
	OSC _{IN}	f _{OSC}	-	12	20	MHz	
Input Sensitivity	f _{in}	P _{f_{in}}	-10	-	6	dBm	50Ω system
	OSC _{IN}	V _{OSC}	0.5	-	-	V _{PP}	
High-level Input Voltage	Clock, Data, LE	V _{IH}	V _{CC} ×0.7	-	-	V	
Low-level Input Voltage		V _{IL}	-	-	V _{CC} ×0.3	V	
High-level Input Current	Data Clock	I _{IH}	-	-	1.0	μA	
Low-level Input Current		I _{IL}	-	-	-1.0	μA	
Input Current	OSC _{IN}	I _{OSC}	-	±50	-	μA	
	LE, FC	I _{LE}	-	-60	-	μA	
High-level Output Voltage	∅R, LD	V _{OH}	4.4	-	-	V	V _{CC} =5V, I _{OH} = -1.0mA
Low-level Output Voltage	∅R, ∅P, LD	V _{OL}	-	-	0.4	V	V _{CC} =5V, I _{OL} = 1.0mA
High impedance Cutoff Current	D _O , ∅P	I _{OFF}	-	-	1.1	μA	V _P =V _{CC} to 6V V _{OOP} =GND to 6V
Output Current	∅R, LD	I _{OH}	-1.0	-	-	mA	V _{CC} =5V
	∅R, ∅P, LD	I _{OL}	-	-	1.0	mA	V _{CC} =5V

*1: f_{in}=1.1GHz, OSC_{IN}=12MHz, V_{CC}=5V. In locked state.

*2: AC coupling. Minimum operating frequency is measured when a capacitor 1000pF is connected.

TEST CIRCUIT (FOR MEASURING INPUT SENSITIVITY f_{in}/OSC_{in})

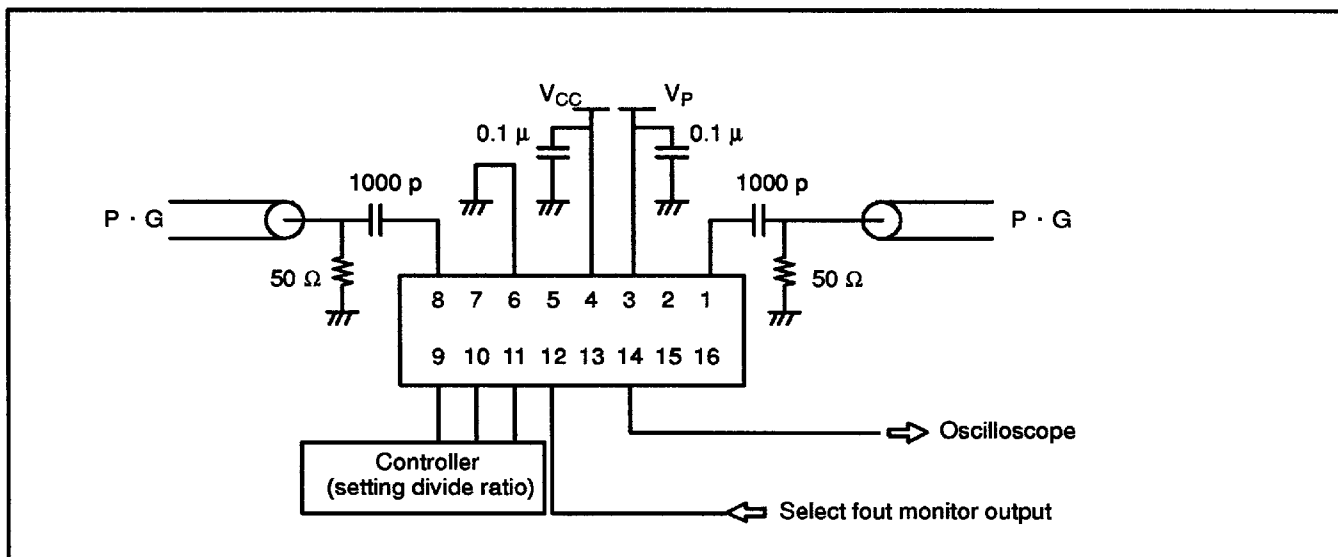

Note : Pin numbers are based on SOP/SSOP 16-pin packages.

TYPICAL APPLICATION EXAMPLE

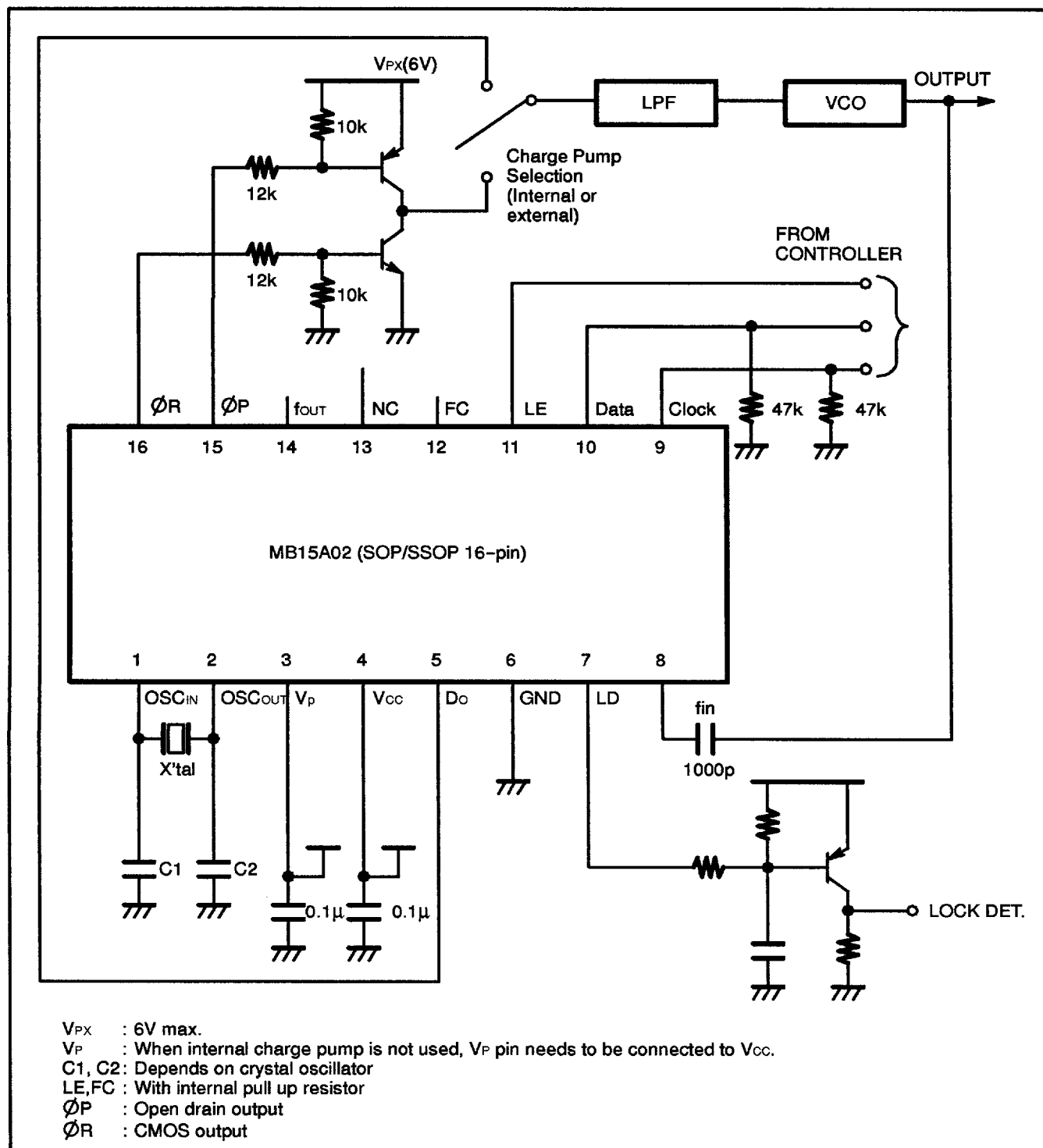

ORDERING INFORMATION

Part Number	Package
MB15A02PF	Plastic SOP, 16-pin FTP-16P-M06
MB15A02PFV1	Plastic SSOP, 16-pin FTP-16P-M05
MB15A02PFV2	Plastic SSOP, 20-pin FTP-20P-M03

PACKAGE DIMENSIONS

16-LEAD PLASTIC FLAT PACKAGE (CASE No.: FPT-16P-M05)

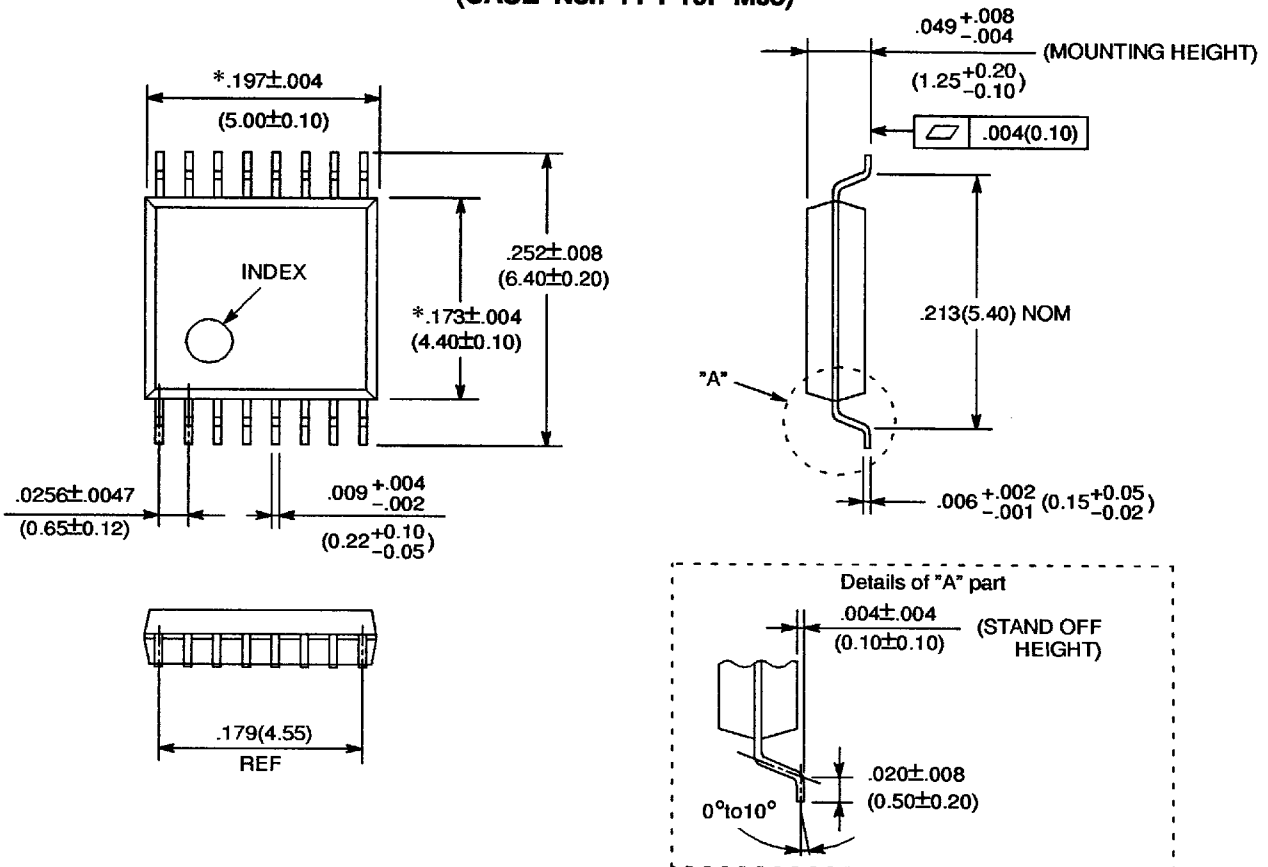

*: This dimension does not include resin protrusion.

©1991 FUJITSU LIMITED F16013S-2C

Dimensions in inches (millimeters)

PACKAGE DIMENSIONS (Continued)

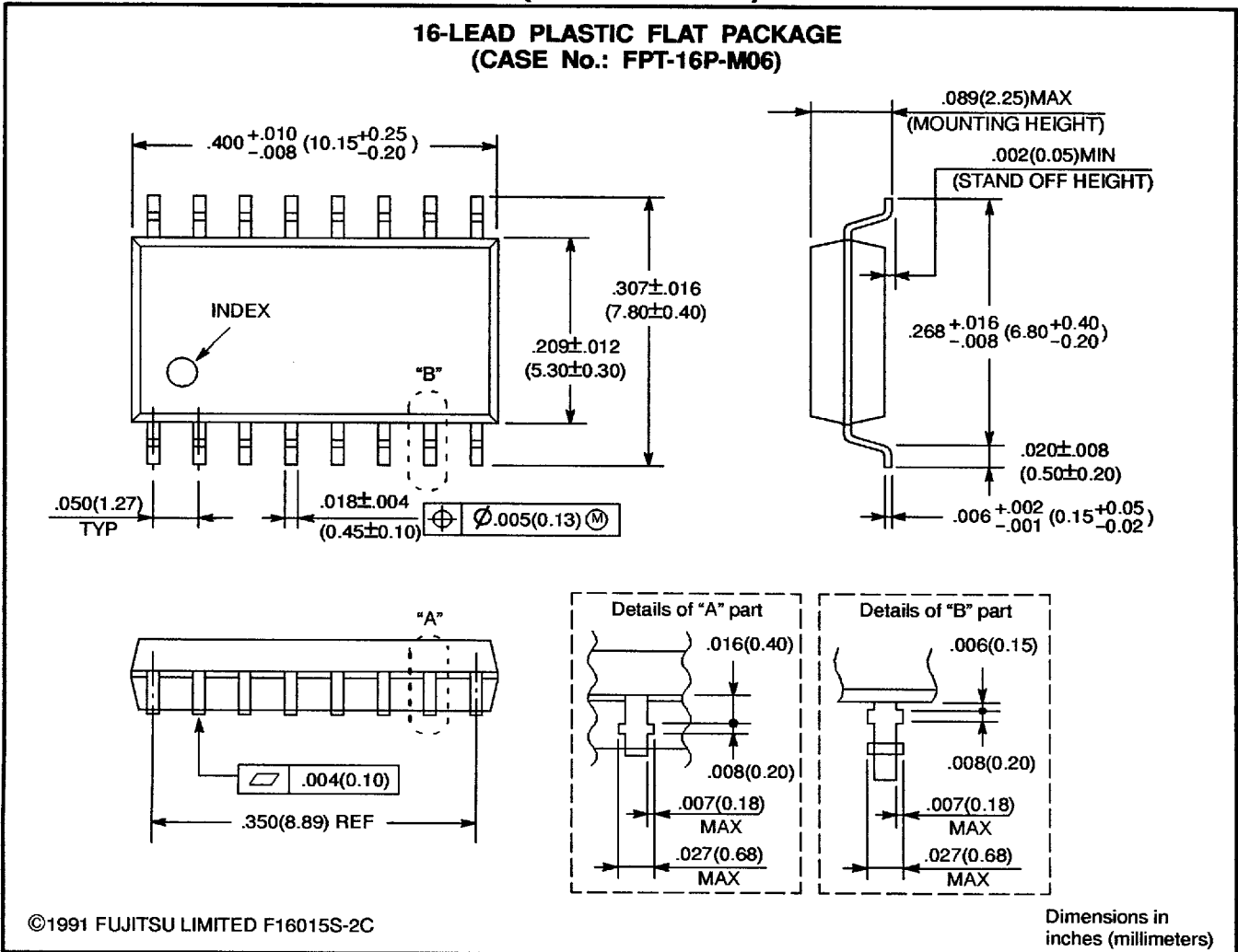

PACKAGE DIMENSIONS (Continued)

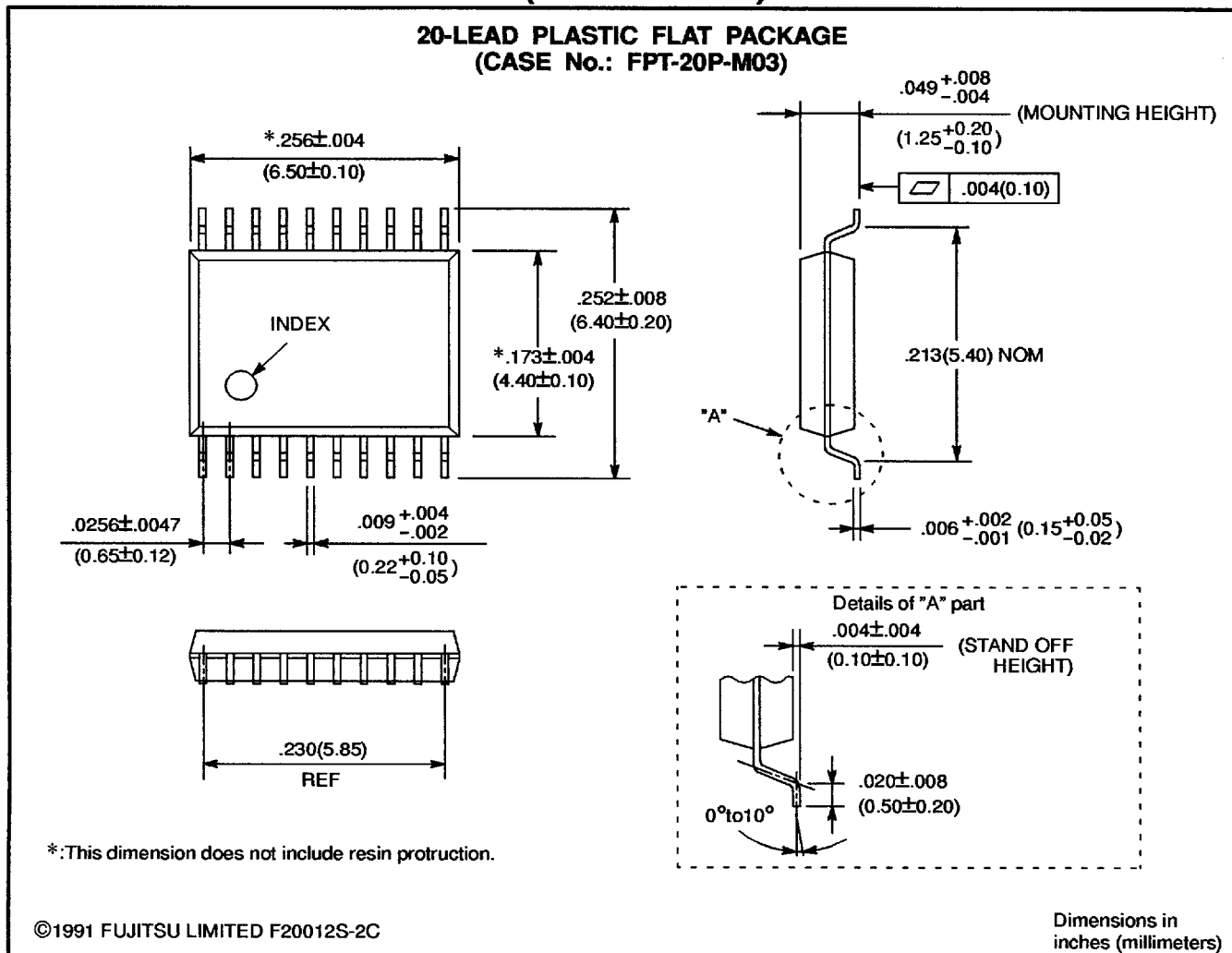

All Rights Reserved.

Circuit diagrams utilizing Fujitsu products are included as a means of illustrating typical semiconductor applications. Complete Information sufficient for construction purposes is not necessarily given.

The Information contained in this document has been carefully checked and is believed to be reliable. However, Fujitsu assumes no responsibility for inaccuracies.

The Information contained in this document does not convey any license under the copyrights, patent rights or trademarks claimed and owned by Fujitsu.

Fujitsu reserves the right to change products or specifications without notice.

No part of this publication may be copied or reproduced in any form or by any means, or transferred to any third party without prior written consent of Fujitsu.

For further information please contact:

Japan

FUJITSU LIMITED
Corporate Global Business Support Division
Electronic Devices
KAWASAKI PLANT, 1015 Kamikodanaka,
Nakahara-ku, Kawasaki-shi,
Kanagawa 211, Japan
Tel: (044) 754-3753
FAX: (044) 754-3329

North and South America

FUJITSU MICROELECTRONICS, INC.
Semiconductor Division
3545 North First Street
San Jose, CA 95134-1804, USA
Tel: (408) 922-9000
FAX: (408) 432-9044/9045

Europe

FUJITSU MIKROELEKTRONIK GmbH
Am Siebenstein 6-10
63303 Dreieich-Buchsschlag,
Germany
Tel: (06103) 690-0
FAX: (06103) 690-122

Asia Pacific

FUJITSU MICROELECTRONICS ASIA PTE LIMITED
No. 51 Bras Basah Road,
Plaza By The Park,
#06-04 to #06-07
Singapore 0718
Tel: 336-1600
FAX: 336-1609

I9503

© FUJITSU LIMITED Printed in Japan

3749756 0009450 759