

HIGH PERFORMANCE CURRENT MODE CONTROLLER

The KIA3842/3/4/5AP/AF are high performance fixed frequency current mode controller. This is specifically designed for Off-Line and DC to DC converter applications offering the designer a cost effective solution with minimal external components. This integrated circuit feature a trimmed oscillator for precise duty cycle control, a temperature compensated reference, high gain error amplifier, current sensing comparator, and a high current totempole output ideally suited for driving a power MOSFET. Also included are protective features consisting of input and reference undervoltage lockouts each with hysteresis, cycle-by-cycle current limiting, programmable output deadtime, and a latch for single pulse metering. Differences between members of this family are the under-voltage lockout thresholds and maximum duty cycle ranges. The KIA3842A and KIA3844A have UVLO thresholds of 16V(on) and 10V(off), ideally suited off-line applications. The corresponding thresholds for the KIA3843A and KIA3845A are 8.5V and 7.9V. The KIA3842A and KIA3843A can operate to duty cycles approaching 100%. A range of the zero to <50% is obtained by the KIA3844A and KIA3845A by the addition of an internal toggle flip flop which balanks the output off every other clock cycle.

FEATURES

- Trimmed Oscillator Discharge Current for Precise Duty Cycle Control.
- Current Mode Operation to 500kHz.
- Automatic Feed Forward Compensation.
- Latching PWM for Cycle-By-Cycle Current Limiting.
- Internally Trimmed Reference with Undervoltage Lockout.
- High Current TotemPole Output.
- Undervoltage Lockout with Hysteresis.
- Low Start-up and Operating Current 0.2mA(Typ.)

MAXIMUM RATING (Ta=25°C)

CHARACTERISTIC	SYMBOL	RATING	UNIT	
Supply Voltage	V _{CC}	30	V	
Output Current, Source of Sink (Note 1)	I _O	1.0	A	
Output Energy (Capacitive Load Per Cycle)	W	5.0	μJ	
Analog Inputs (Pin ②, ③)	V _{IN}	-0.3 to + 6.3	V	
Error Amp Output Sink Current	I _O	10	mA	
Power Dissipation	KIA384XAP	P _D	1.25	W
	KIA384XAF		800	mW
Operating Temperature	T _a	0 to + 70	°C	
Storage Temperature	T _{stg}	-65 to + 150	°C	

NOTE : 1. Maximum package power dissipation limits must be observed.

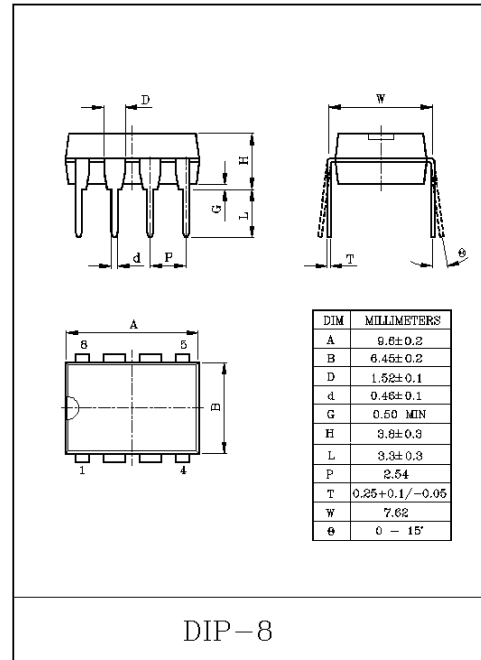

DIP-8

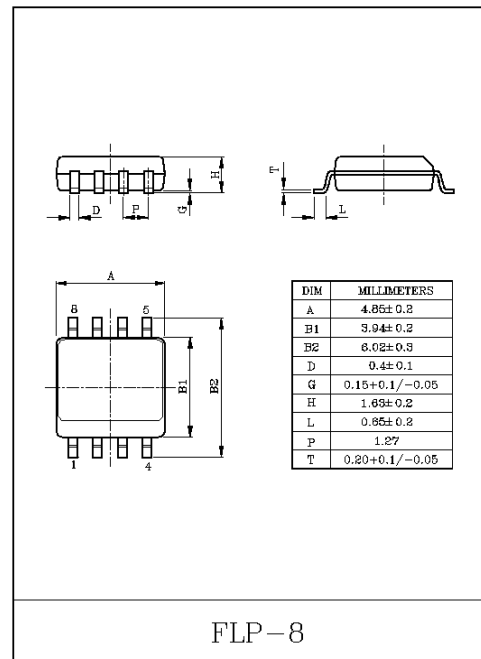

FLP-8

KIA3842/3/4/5AP/AF

PIN CONNECTIONS (TOP VIEW)

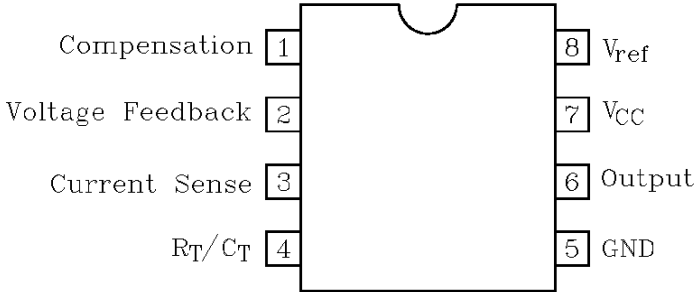

BLOCK DIAGRAM

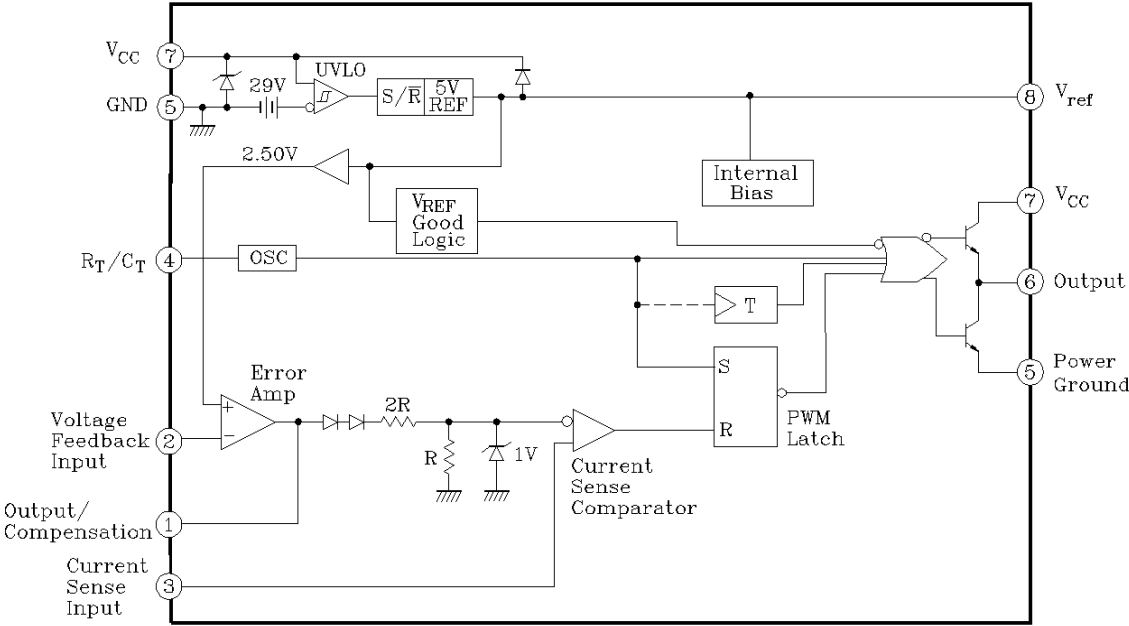

KIA3842/3/4/5AP/AF

ELECTRICAL CHARACTERISTICS (V_{CC}=15V (Note 2), R_T=10kΩ, C_T=3.3nF, T_a=25°C)

REFERENCE SECTION

CHARACTERISTIC	SYMBOL	TEST CONDITION	MIN.	TYP.	MAX.	UNIT
Reference Output Voltage	V _{ref}	I _O =1.0mA, T _a =25°C	4.9	5.0	5.1	V
Line Regulation	Reg _{line}	12V ≤ V _{IN} ≤ 25V	-	2.0	20	mV
Load Regulation	Reg _{load}	1mA ≤ I _O ≤ 20mA	-	3.0	25	mV
Temperature Stability	T _S	-	-	0.2	-	mV/°C
Total Output Variation over Line, Load, and Temperature	V _{ref}	-	4.82	-	5.18	V
Output Noise Voltage	V _{no}	10Hz ≤ f ≤ 10kHz, T _a =25°C	-	50	-	μV
Long Term Stability	S	T _a =125°C, 1000Hrs	-	5.0	-	mV
Output Short Circuit Current	I _{SC}	-	-30	-85	-180	mA

OSCILLATOR SECTION

CHARACTERISTIC	SYMBOL	TEST CONDITION	MIN.	TYP.	MAX.	UNIT
Frequency	f _{osc}	T _a =25°C	47	52	57	kHz
Frequency Change With Voltage	Δf _{osc} /ΔV	12V ≤ V _{CC} ≤ 25V	-	0.2	1.0	%
Frequency Change With Temperature	Δf _{osc} /ΔT	0 ≤ T _a ≤ 70°C	-	5.0	-	%
Oscillator Voltage Swing	V _{OSC}	4 PIN Peak to Peak	-	1.7	-	V
Discharge Current	I _{dischg}	V _{PIN4} =2V	7.8	8.3	8.8	mA

ERROR AMPLIFIER SECTION

CHARACTERISTIC	SYMBOL	TEST CONDITION	MIN.	TYP.	MAX.	UNIT
Voltage Feedback Input	V _{FB}	V _{PIN1} =2.5V	2.42	2.5	2.58	V
Input Bias Current	I _{IB}	-	-	-0.3	-2.0	μA
Open-Loop Voltage Gain	A _{VOL}	2V ≤ V _O ≤ 4V	65	90	-	μA
Unity Gain Bandwidth	BW	T _a =25°C	0.7	1.0	-	MHz
Power Supply Rejection Ratio	PSRR	12V ≤ V _{CC} ≤ 25V	60	70	-	dB
Output Sink Current	I _{sink}	V _{PIN2} =2.7V, V _{PIN1} =1.1V	2.0	12	-	mA
Output Source Current	I _{source}	V _{PIN2} =2.3V, V _{PIN1} =5V	-0.5	-0.8	-	
Vout High	V _{OH}	R _L =15k to GND, V _{PIN2} =2.3V	5.0	6.0	-	V
Vout Low	V _{OL}	R _L =15k to Ref, V _{PIN2} =2.7V	-	0.7	1.1	

CURRENT SENSE SECTION

CHARACTERISTIC	SYMBOL	TEST CONDITION	MIN.	TYP.	MAX.	UNIT
Current Sense Input Voltage Gain	A _V	V _{FB} =0, V _{IN} =0~0.8V A _V = $\frac{\Delta V \text{ output Compensation}}{\Delta V \text{ Current Sense Input}}$	2.85	3.0	3.15	V/V
Maximum Current Sense Input Threshold	V _{th}	V _{PIN1} =5V, V _{PIN2} =0V	0.9	1.0	1.1	V
Power Supply Rejection Ratio	PSRR	12V ≤ V _{CC} ≤ 25V, V _{PIN2} =0V	-	70	-	dB
Input Bias Current	I _{IB}	-	-	-2.0	-10	μA
Propagation Delay	t _{PLH(IN/OUT)}	Current Sense Input to Output, V _{PIN3} =0 to 2V	-	100	200	nS

KIA3842/3/4/5AP/AF

OUTPUT SECTION

CHARACTERISTIC	SYMBOL	TEST CONDITION	MIN.	TYP.	MAX.	UNIT
Low State Output Voltage	V_{OL}	$I_{sink}=20mA$	-	0.1	0.4	V
		$I_{sink}=200mA$	-	1.5	2.2	
High State Output Voltage	V_{OH}	$I_{source}=20mA$	13	13.5	-	V
		$I_{source}=200mA$	12	13.5	-	
Rise Time	t_r	$C_L=1.0nF, V_{FB}=0$	-	40	100	nS
Fall Time	t_f	$C_L=1.0nF, V_{FB}=0$	-	40	100	nS
UVLO Saturation	V_{OLS}	$V_{CC}=6V, I_{SINK}=1mA$	-	0.7	1.2	V
Output Voltage Swing Limit	V_{OLIM}	$V_{CC}=27V, C_1=1nF$	-	22	-	V

UNDER VOLTAGE LOCKOUT SECTION

CHARACTERISTIC	SYMBOL	TEST CONDITION	MIN.	TYP.	MAX.	UNIT	
Start-up Threshold Voltage	V_{TH}	KIA3842/4A	14.5	16	17.5	V	
		KIA3843/5A	7.8	8.4	9.0		
Minimum Operating Voltage	$V_{CC(min)}$	After Turn ON	KIA3842/4A	8.5	10	11.5	V
		KIA3843/5A	7.0	7.6	8.2		

PWM SECTION

CHARACTERISTIC	SYMBOL	TEST CONDITION	MIN.	TYP.	MAX.	UNIT
Duty Cycle Max.	DC_{max}	KIA3842/3A	94	96	100	%
		KIA3844/5A	47	48	50	
Duty Cycle Min.	DC_{min}		-	-	0	%

TOTAL DEVICE

CHARACTERISTIC	SYMBOL	TEST CONDITION	MIN.	TYP.	MAX.	UNIT
Power Supply Current	I_{CC}	$V_{CC}=14V$	-	0.2	0.5	mA
		$V_{CC}=15V, \text{ after turn ON}$	-	11	17	
Power Supply Zener Voltage	V_Z	$I_{CC}=25mA$	-	29	-	V

KIA3842/3/4/5AP/AF

TEST CIRCUIT

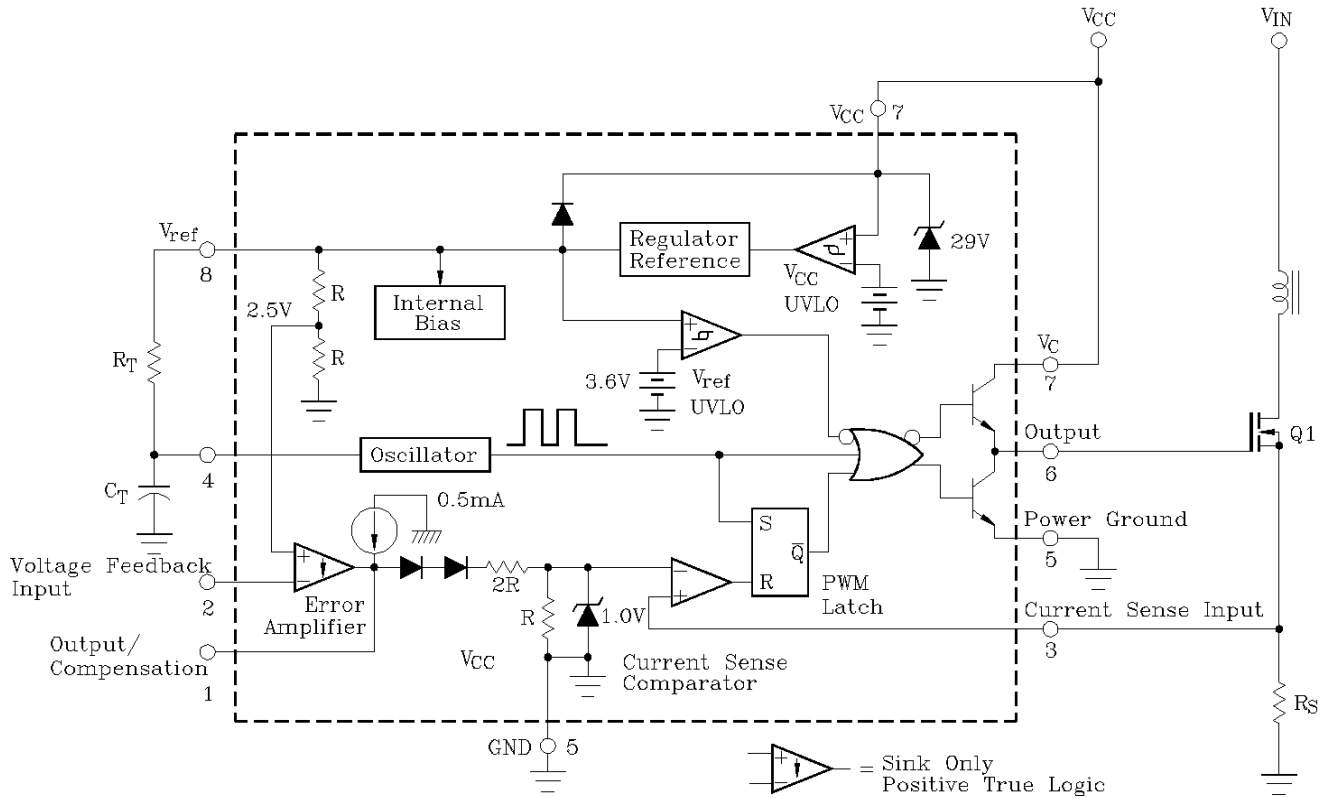

KIA3842/3/4/5AP/AF

PIN FUNCTION DESCRIPTION

PIN NO.	FUNCTION	DESCRIPTION
1	Compensation	This pin is the Error Amplifier output and is made available for loop compensation.
2	Voltage Feedback	This is the inverting input of the Error amplifier. It is normally connected to the switching power supply output through a resistor divider.
3	Current Sense	A voltage proportional to inductor current is connected to this input. The PWM uses this information to terminate the output switch conduction.
4	R_T/C_T	The Oscillator frequency and maximum Output duty Cycle are programmed by connecting resistor R_T to V_{ref} and capacitor C_T to ground. Operation to 500kHz is possible.
5	GND	This pin is the combined control circuitry and power ground (8-pin package only).
6	Output	This output directly drives the gate of a power MOSFET. Peak currents up to 1.0A are sourced and sunk by this pin.
7	V_{CC}	This pin is the positive supply of the control IC.
8	V_{ref}	This is the reference output. It provides charging current for capacitor C_T through resistor R_T .

KIA3842/3/4/5AP/AF

