

PTF 10195

125 Watts, 869–894 MHz

GOLDMOS[®] Field Effect Transistor

Description

The 10195 is an internally matched 125-watt GOLDMOSFET intended for cellular, GSM, D-AMPS, CDMA and EDGE applications. This device operates at 53% efficiency with 13 dB of gain minimum. Full gold metallization ensures excellent device lifetime and reliability.

- **INTERNALLY MATCHED**
- **Performance at 894 MHz, 28 Volts**
 - Output Power = 125 Watts
 - Power Gain = 14 dB Typical
 - Efficiency = 53% Typical
- **Full Gold Metallization**
- **Excellent Thermal Stability**
- **100% Lot Traceability**

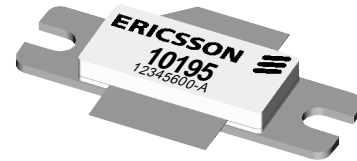
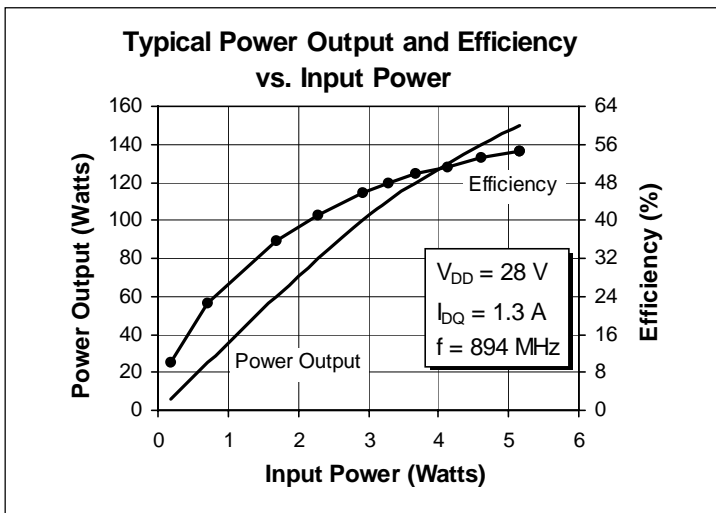

Package 20248

RF Specifications (100% Tested)

Characteristic	Symbol	Min	Typ	Max	Units
Gain ($V_{DD} = 28\text{ V}$, $P_{OUT} = 125\text{ W}$, $I_{DQ} = 1300\text{ mA}$, $f = 894\text{ MHz}$)	G_{pe}	13	14	—	dB
Power Output at 1 dB Compression ($V_{DD} = 28\text{ V}$, $I_{DQ} = 1300\text{ mA}$, $f = 894\text{ MHz}$)	P-1dB	125	140	—	Watts
Drain Efficiency ($V_{DD} = 28\text{ V}$, $P_{OUT} = 125\text{ W}$, $I_{DQ} = 1300\text{ mA}$, $f = 894\text{ MHz}$)	η	45	53	—	%
Load Mismatch Tolerance ($V_{DD} = 28\text{ V}$, $P_{OUT} = 125\text{ W}$, $I_{DQ} = 1300\text{ mA}$, $f = 894\text{ MHz}$ —all phase angles at frequency of test)	Ψ	10:1	—	—	—

All published data at $T_{CASE} = 25^{\circ}\text{C}$ unless otherwise indicated.

Electrical Characteristics (100% Tested)

Characteristic	Conditions	Symbol	Min	Typ	Max	Units
Drain-Source Breakdown Voltage	$V_{GS} = 0\text{ V}, I_D = 25\text{ mA}$	$V_{(BR)DSS}$	65	—	—	Volts
Drain-Source Leakage Current	$V_{DS} = 26\text{ V}, V_{GS} = 0\text{ V}$	I_{DSS}	—	—	1.0	mA
Gate Threshold Voltage	$V_{DS} = 10\text{ V}, I_D = 100\text{ mA}$	$V_{GS(th)}$	3.0	—	5.0	Volts
Forward Transconductance	$V_{DS} = 10\text{ V}, I_D = 3\text{ A}$	g_{fs}	—	3.0	—	Siemens

Maximum Ratings

Parameter	Symbol	Value	Unit
Drain-Source Voltage	V_{DSS}	65	Vdc
Gate-Source Voltage	V_{GS}	± 20	Vdc
Operating Junction Temperature	T_J	200	$^{\circ}\text{C}$
Total Device Dissipation Above 25°C derate by	P_D	266 1.52	Watts $\text{W}/^{\circ}\text{C}$
Storage Temperature Range	T_{STG}	-40 to +150	$^{\circ}\text{C}$
Thermal Resistance ($T_{CASE} = 70^{\circ}\text{C}$)	$R_{\theta JC}$.66	$^{\circ}\text{C}/\text{W}$

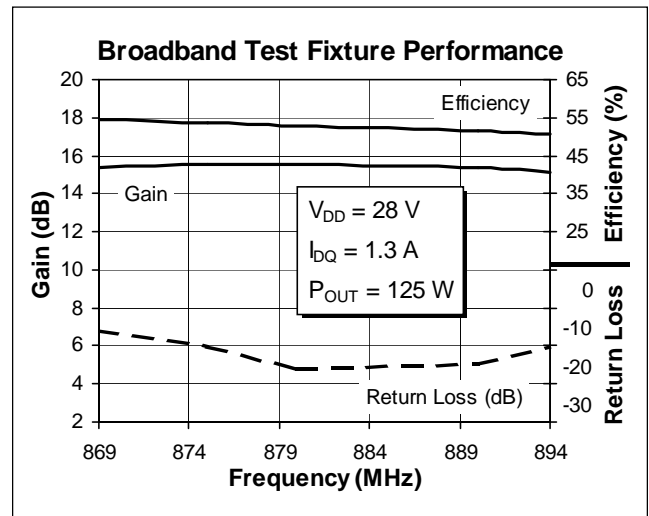
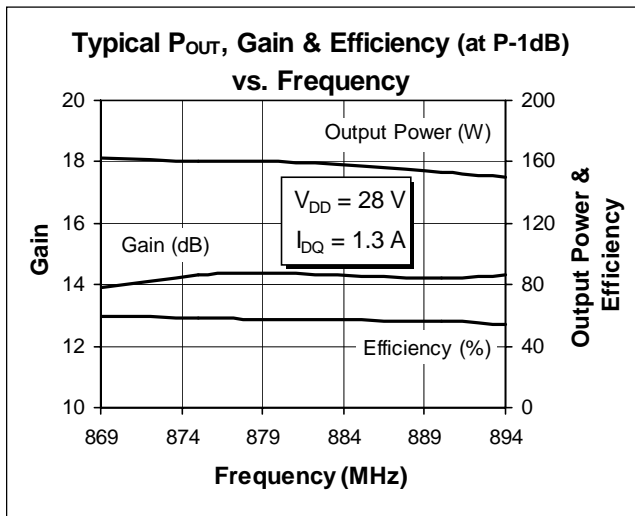

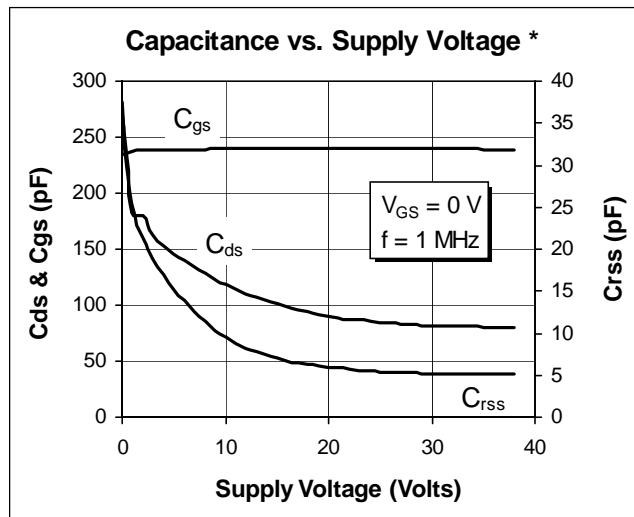
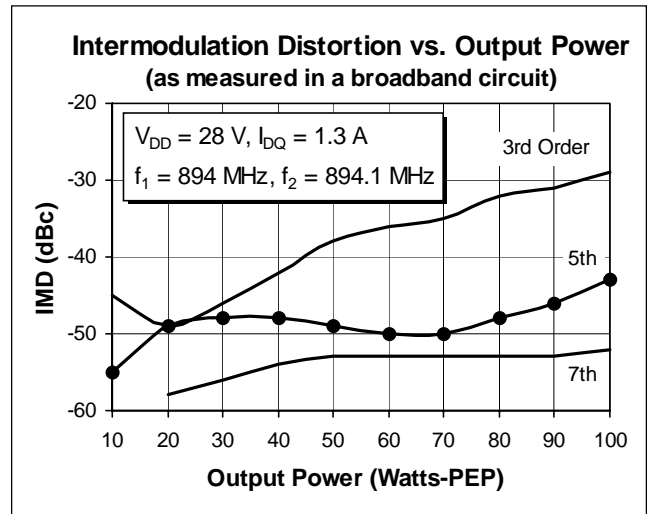
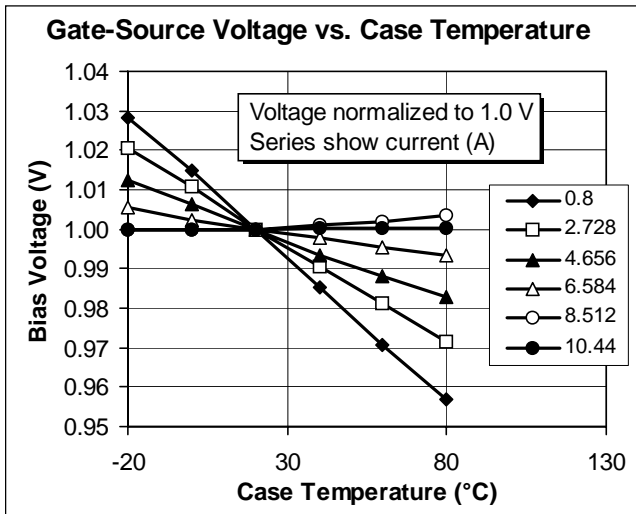
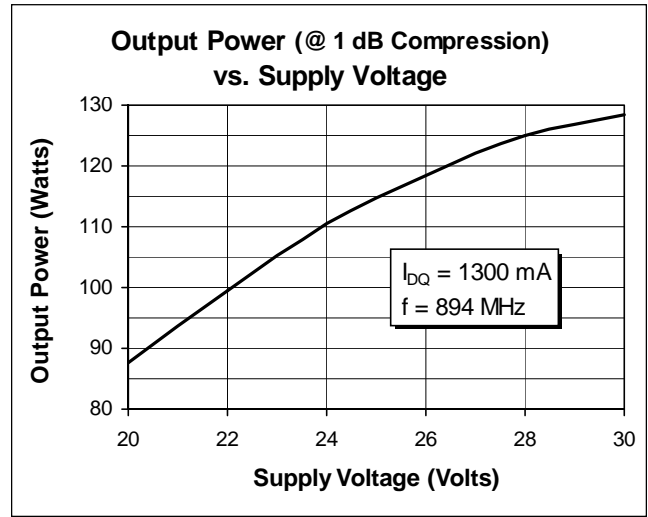
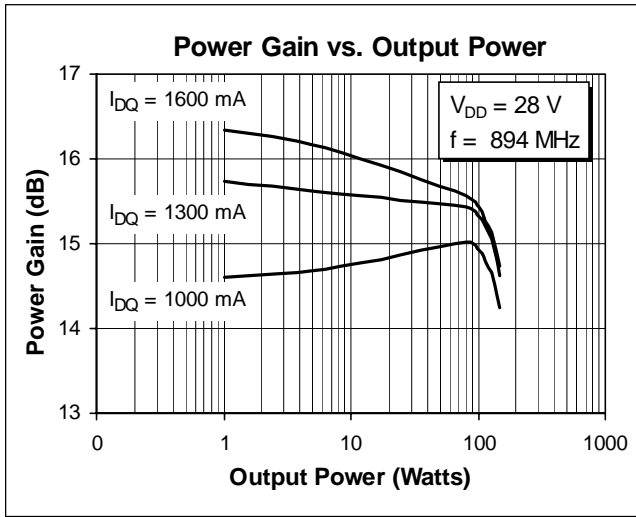

* This part is internally matched. Measurements of the finished product will not yield these figures.

Impedance Data

$V_{DD} = 28\text{ V}$, $P_{OUT} = 125\text{ W}$, $I_{DQ} = 1300\text{ mA}$

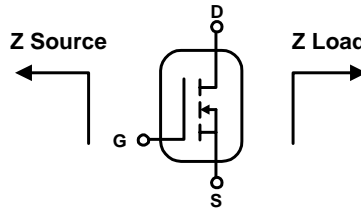

Frequency MHz	Z Source Ω		Z Load Ω	
	R	jX	R	jX
860	1.97	-1.13	2.30	0.99
869	1.86	-0.94	2.18	1.19
880	1.69	-0.73	2.00	1.38
894	1.52	-0.44	1.79	1.63
905	1.39	-0.22	1.69	1.85

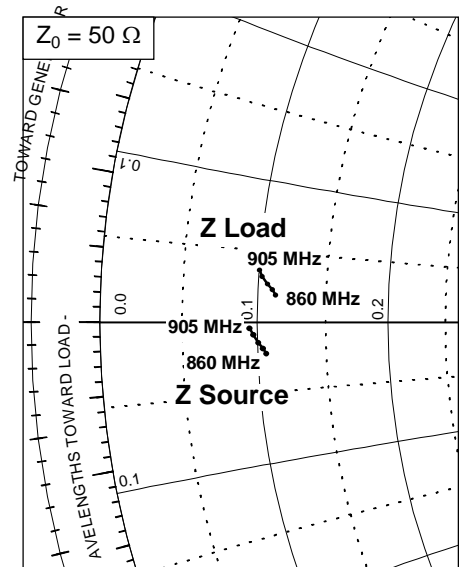

Test Circuit

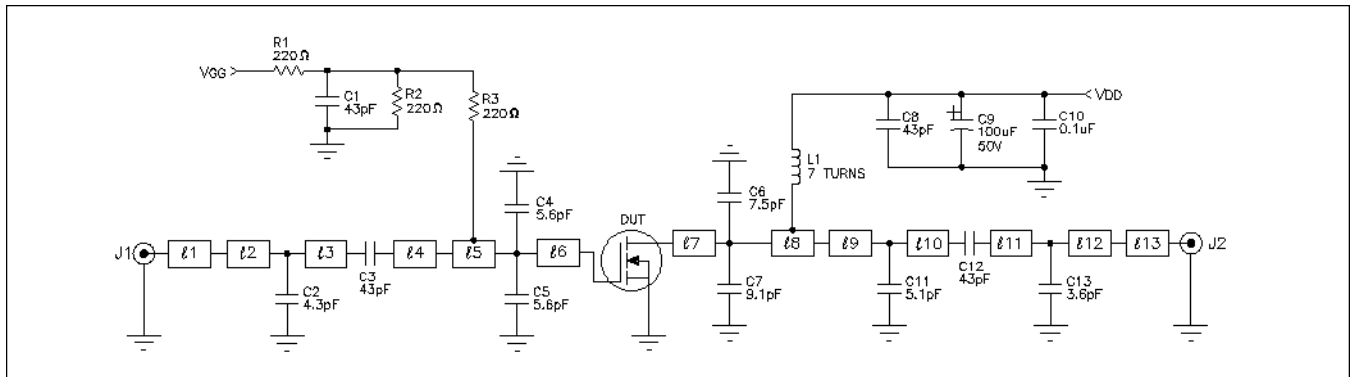

Test Circuit Schematic for $f = 894\text{ MHz}$

DUT	PTF 10195	LDMOS Transistor
$l1$	0.0273λ	894 MHz Microstrip $50\ \Omega$
$l2$	0.0244λ	894 MHz Microstrip $30\ \Omega$
$l3$	0.0204λ	894 MHz Microstrip $30\ \Omega$
$l4$	0.1800λ	894 MHz Microstrip $30\ \Omega$
$l5$	0.0715λ	894 MHz Microstrip $8.63\ \Omega$
$l6$	0.0802λ	894 MHz Microstrip $8.63\ \Omega$
$l7$	0.1026λ	894 MHz Microstrip $8.63\ \Omega$
$l8$	0.0491λ	894 MHz Microstrip $8.63\ \Omega$
$l9$	0.0389λ	894 MHz Microstrip $30\ \Omega$
$l10$	0.1411λ	894 MHz Microstrip $30\ \Omega$
$l11$	0.0116λ	894 MHz Microstrip $30\ \Omega$
$l12$	0.0428λ	894 MHz Microstrip $30\ \Omega$
$l13$	0.0293λ	894 MHz Microstrip $50\ \Omega$

C1, C3, C8, C12	Capacitor, 43pF	100B 430
C2	Capacitor, 4.3pF	100B 4R3
C4, C5	Capacitor, 5.6pF	100B 5R6
C6	Capacitor, 7.5pF	100B 7R5
C7	Capacitor, 9.1pF	100B 9R1
C11	Capacitor, 5.1pF	100B 5R1
C13	Capacitor, 3.6pF	100B 3R6
C10	Capacitor, 0.1uF	Digi-KeyP4525-ND
C9	Capacitor, 100uF, 50V	Digi-KeyP5182-ND
J1, J2	Connector, SMA, Female, Panel Mount	1301-RPM 513 412/53
L1	7 Turns, 22AWG, .120 DIA I.D.	N/A
R1, R2, R3	Resistor, 220ohm	Digi-Key 220QBK-ND
Circuit Board	.031" thick, $\epsilon_r = 4.0$, G200	AlliedSignal

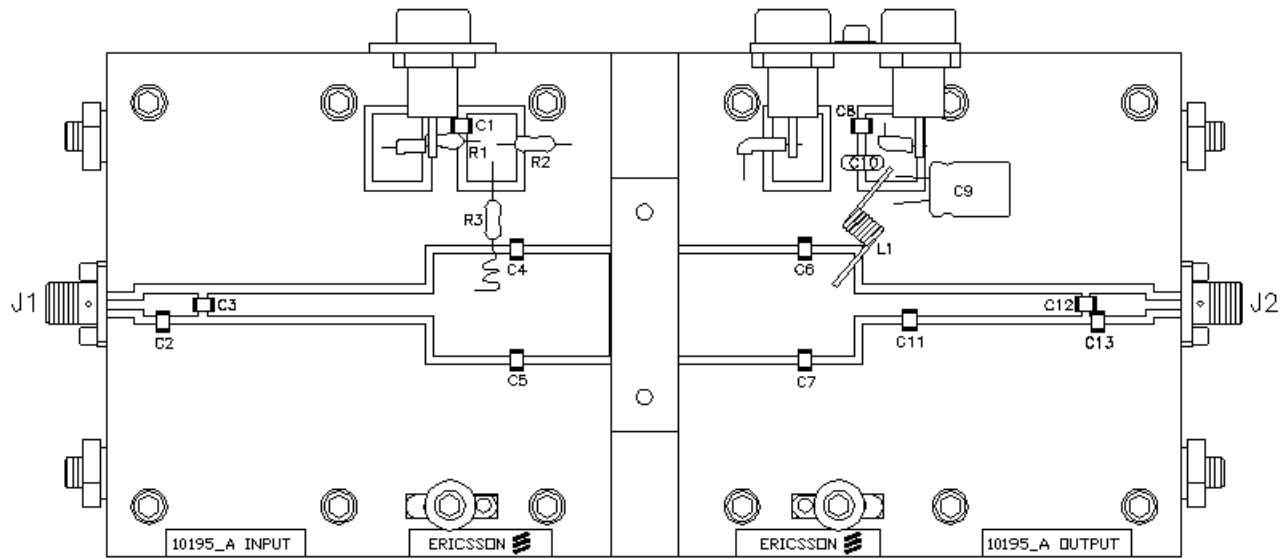

Components Layout (not to scale)

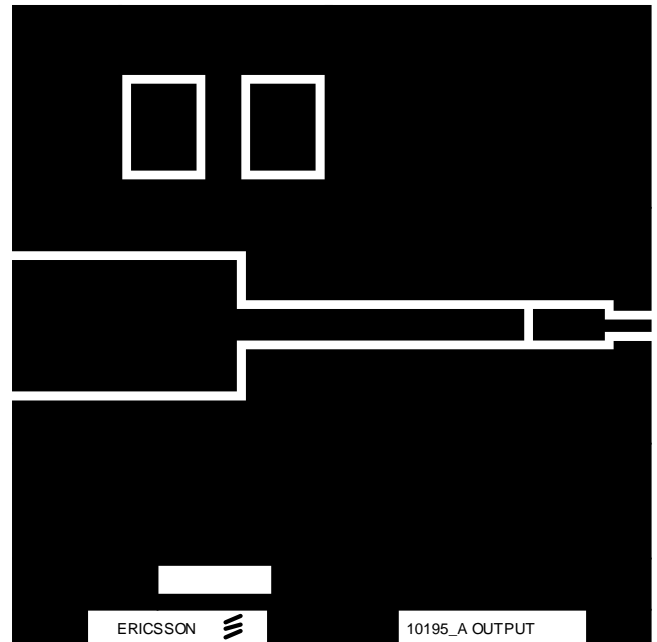
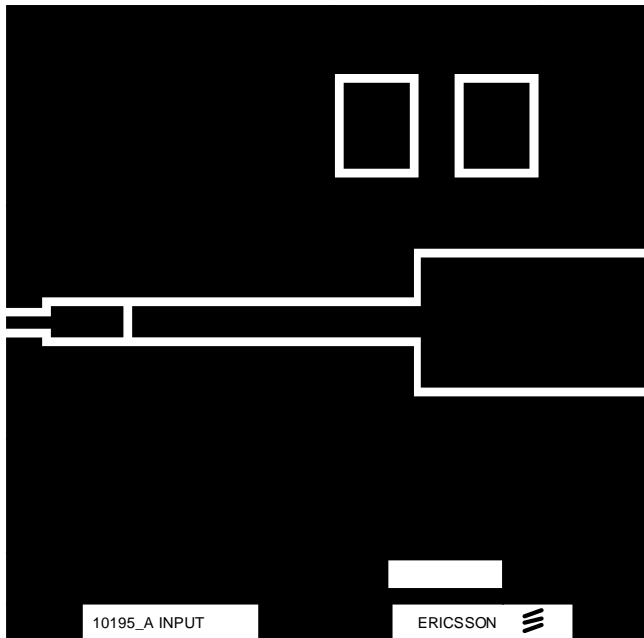

Artwork (not to scale)

Case Outline Specifications

